

ROBOTICS

Product manual

IRC5



Trace back information:
Workspace 25-3 version a23
Checked in 2025-11-05
Skribenta version 5.6.019

Product manual

IRC5

Design 14

Document ID: 3HAC047136-001

Revision: AH

The information in this manual is subject to change without notice and should not be construed as a commitment by ABB. ABB assumes no responsibility for any errors that may appear in this manual.

Except as may be expressly stated anywhere in this manual, nothing herein shall be construed as any kind of guarantee or warranty by ABB for losses, damage to persons or property, fitness for a specific purpose or the like.

In no event shall ABB be liable for incidental or consequential damages arising from use of this manual and products described herein.

This manual and parts thereof must not be reproduced or copied without ABB's written permission.

Keep for future reference.

Additional copies of this manual may be obtained from ABB.

Original instructions.

© Copyright 2004-2025 ABB. All rights reserved.
Specifications subject to change without notice.

Table of contents

Overview of this manual	9
Product documentation	15
Network security	17
1 Safety	19
1.1 Safety information	19
1.1.1 Limitation of liability	19
1.1.2 Safety data	20
1.1.3 Requirements on personnel	23
1.2 Safety signals and symbols	24
1.2.1 Safety signals in the manual	24
1.2.2 Safety symbols on controller labels	26
1.3 Robot stopping functions	29
1.3.1 Protective stop and emergency stop	29
1.3.2 About emergency stop	31
1.3.3 Enabling device and hold-to-run functionality	32
1.4 Robot operating modes	33
1.4.1 About the manual mode	33
1.4.2 About the automatic mode	35
1.5 Safety during installation and commissioning	36
1.6 Safety during operation	39
1.7 Safety during maintenance and repair	40
1.8 Safety during troubleshooting	41
1.9 Safety during decommissioning	42
2 Installation and commissioning	43
2.1 Overview	43
2.2 Installation activities	45
2.3 Transporting and handling	46
2.3.1 Lifting the controller cabinet	46
2.3.2 Unpacking the controller	47
2.3.3 The unit is sensitive to ESD	49
2.4 On-site installation	50
2.4.1 Required installation space, IRC5 Controller	50
2.4.2 Bolting down the controller	51
2.4.3 Transportation screws	52
2.4.4 Mounting the FlexPendant holder	53
2.5 Connections	60
2.5.1 Connectors on the controller	60
2.5.2 Connecting cables to the controller	62
2.5.3 Power supply system requirements	69
2.5.4 Connecting power supply to the controller	72
2.5.5 Connecting the manipulator to the controller	78
2.5.6 Connecting safety signals	79
2.5.7 Connection of external safety relay	81
2.5.8 Closing the Automatic Stop circuit	82
2.5.9 Connection of the MOTORS ON/MOTORS OFF circuit	83
2.5.10 Connection to MOTORS ON/MOTORS OFF contactor	89
2.5.11 Connecting a FlexPendant	91
2.5.12 Using the hot plug option	94
2.5.13 Connectors on the computer unit	97
2.5.14 Connecting a serial channel to the controller	101
2.5.15 Programmable stop functions	103
2.5.16 Connection of drive module	106
2.5.17 Connection of Drive Module Disconnect, by limit switch	108
2.5.18 Connection of servo disconnect, by servo power switch	112

Table of contents

2.5.19	Connecting a Limit switch override push button	114
2.6	Drive system	117
2.6.1	Drive functions, general	117
2.6.2	Configuration of the drive system	118
2.7	Memory functions	121
2.7.1	Memory functions	121
2.7.2	Connecting a USB memory	122
2.8	I/O system	123
2.8.1	Definition of fieldbuses, IRC5	123
2.8.2	Scalable I/O devices	127
2.8.3	DeviceNet I/O units	129
2.8.4	Conveyor tracking module	131
2.9	Installation of add-ons	133
2.9.1	Installation of external operator's panel, IRC5	133
2.9.2	Installation of external enabling device	137
2.9.3	Installation of Scalable I/O devices	139
2.9.4	Installation of DeviceNet I/O, Gateways and encoder interface units, IRC5	142
2.9.5	Installation of conveyor tracking module	144
2.9.6	Installation of cooling fan harness axis 1 and 2	147
2.9.7	Installation of the option Hot plug	150
2.9.8	Installing the EPS board DSQC 646 for Electronic Position Switches	154
2.9.9	Installing the SafeMove board DSQC 647	160
2.9.10	Installing the Safety module DSQC1015 for SafeMove	168
2.9.11	Installation of DispensePac support	179
2.9.12	Installation of additional drive units	180
2.9.13	Installation of additional Drive Module	187
2.9.14	Process module	188
2.9.15	Installation of drive system fans with temperature sensors	191
2.9.16	Installation of the mains connection cable	197
2.10	Testing	200
3	Maintenance	201
3.1	Maintenance schedule for the IRC5 controller	201
3.2	Inspection activities	203
3.2.1	Inspection of the controller	203
3.3	Changing/replacing activities	205
3.3.1	Replacement of moist dust filter	205
3.4	Cleaning activities	208
3.4.1	Cleaning of the controller cabinet	208
3.4.2	Cleaning moist dust filter	209
3.4.3	Cleaning the FlexPendant	211
3.5	Function tests	213
3.5.1	Function test of earth fault breaker F4	213
3.5.2	Function test of emergency stop	214
3.5.3	Function test of mode switch	215
3.5.4	Function test of three-position enabling device	216
3.5.5	Function test of motor contactors K42 and K43	217
3.5.6	Function test of brake contactor K44	218
3.5.7	Function test of Automatic Stop	219
3.5.8	Function test of General Stop	220
3.5.9	Function test of superior stop	221
3.5.10	Function test of limit switch	222
3.5.11	Function test of automatic fuse F1	223
3.5.12	Function test of reduced speed control	224
4	Repair	225
4.1	Overview	225
4.2	Replacement of panel board	226
4.3	Replacement of Flange disconnect	229

4.4	Replacement of I/O units and Gateways	232
4.5	Replacement of backup energy bank	234
4.6	Replacement of heat exchange unit and fan	236
4.7	Replacement of computer unit	240
4.8	Replacement of PCIeexpress boards in the computer unit	244
4.9	Replacement of expansion board in the computer unit	248
4.10	Replacement of fieldbus adapter in the computer unit	251
4.11	Replacement of fan in computer unit	256
4.12	Replacement of SD-card memory in computer unit	259
4.13	Replacement of drive units	262
4.14	Replacement of Axis computer	265
4.15	Replacement of EPS board DSQC 646 for Electronic Position Switches	267
4.16	Replacement of SafeMove board DSQC 647	271
4.17	Replacement of Safety module DSQC1015 for SafeMove	275
4.18	Replacement of Remote Service box	278
4.19	Replacement of Contactor Interface Board	281
4.20	Replacement of drive system fans	284
4.21	Replacement of sensors for the drive system fans	287
4.22	Replacement of transformer unit	291
4.23	Replacement of brake resistor bleeder	294
4.24	Replacement of Process Interface Board	299
4.25	Replacement of Ethernet switch	301
4.26	Replacement of power supply	303
4.26.1	Replacement of power distribution unit	303
4.26.2	Replacement of customer I/O power supply	306
4.26.3	Replacement of system power supply	309
5	Decommissioning	313
5.1	Introduction to decommissioning	313
5.2	Environmental information	314
6	Reference information	317
6.1	Introduction	317
6.2	Applicable standards	318
6.3	Unit conversion	320
6.4	Screw joints	321
6.5	Weight specifications	322
6.6	Standard toolkit, IRC5	323
6.7	Lifting accessories and lifting instructions	324
6.8	Open source and 3rd party components	325
7	Spare parts	327
7.1	Controller parts	327
7.2	FlexPendant parts	334
7.3	Manipulator cables	336
7.3.1	Manipulator cables	336
7.3.2	Fan cables	341
7.3.3	CP/CS Harness	342
7.3.4	Cables customer power/customer signal	343
7.3.5	Other customer cables	346
7.3.6	Additional cables	347
8	Circuit diagrams	349
8.1	Circuit diagrams	349
Index		351

This page is intentionally left blank

Overview of this manual

About this manual

This manual contains instructions for:

- installing the controller, mechanically as well as electrically.
- maintenance of the controller.
- mechanical and electrical repair of the controller.

Usage

This manual should be used during:

- installation and preparation work.
- maintenance work.
- repair work.

Who should read this manual?

This manual is intended for:

- installation personnel.
- maintenance personnel.
- repair personnel.

Prerequisites

Maintenance/repair/installation personnel working with an ABB Robot must:

- be trained by ABB and have the required knowledge of mechanical and electrical installation/repair/maintenance work.

References

Reference	Document ID
<i>Operating manual - Emergency safety information</i>	3HAC027098-001
<i>Operating manual - IRC5 with FlexPendant</i>	3HAC050941-001
<i>Operating manual - RobotStudio</i>	3HAC032104-001
<i>Operating manual - Getting started, IRC5 and RobotStudio</i>	3HAC027097-001
<i>Operating manual - Troubleshooting IRC5</i>	3HAC020738-001
<i>Application manual - MultiMove</i>	3HAC050961-001
<i>Application manual - Additional axes and standalone controller</i>	3HAC051016-001
<i>Application manual - Force Control</i>	3HAC050377-001
<i>Application manual - SafeMove1</i>	3HAC050974-001
<i>Application manual - Electronic Position Switches</i>	3HAC050996-001
<i>Application manual - Functional safety and SafeMove2</i>	3HAC052610-001
<i>Technical reference manual - RAPID Instructions, Functions and Data types</i>	3HAC050917-001
<i>Technical reference manual - System parameters</i>	3HAC050948-001
<i>Product specification - Controller IRC5</i>	3HAC047400-001

Continues on next page

Reference	Document ID
See Circuit diagrams on page 349 .	



Note

The document numbers that are listed for software documents are valid for RobotWare 6. Equivalent documents are available for RobotWare 5.

Revisions

Revision	Description
-	First edition. Released with the new computer unit, DSQC1000.
A	<ul style="list-style-type: none"> Added information on how to replace the fan in the computer unit, see Replacement of fan in computer unit on page 256. Corrected the spare parts list for controller system parts, see Controller parts on page 327. Added information on how to install an additional drive module, see Installation of additional Drive Module on page 187. Added information on how to install an additional drive unit, see Installation of additional drive units on page 180. Added the IRB 1520 manipulator cables to the spare parts list, see Manipulator cables on page 336.
B	<ul style="list-style-type: none"> Added the MultiMove switch to the spare parts list, see Controller parts on page 327. Article numbers for manipulator cables, IRB 120 added, see Manipulator cables on page 336. Article number for DeviceNet Slave (DSQC 1004) changed. See Definition of fieldbuses, IRC5 on page 123 Added information about labels on the controller, see Safety symbols on controller labels on page 26. Minor corrections.
C	<ul style="list-style-type: none"> New computer unit, DSQC1018, with two PCI slots and no knockout plates. No functional change, but affects illustrations. Added new section, Additional cables on page 347, with drive module cables. Added section Process module on page 188. Clarified the use of the WAN port in section Connectors on the computer unit on page 97.
D	<ul style="list-style-type: none"> Some changes on how the ports can be configured and used is described in section Connectors on the computer unit on page 97.

Revision	Description
E	<p>Release 15.2.</p> <ul style="list-style-type: none"> • Minor corrections. • Added safety-related information related to mode switch keys, Installation of external enabling device on page 137, Function tests on page 213, and Refurbish. • Updates in section Applicable standards on page 318. • Added section Safety data on page 20. • Added section Replacement of sensors for the drive system fans on page 287. Also some information about the temperature sensors when replacing MDU and drive system fans. • Updated picture and table of cables to the hot plug connector in section Installation of the option Hot plug on page 150. • System fan removed
F	<p>Release 16.1.</p> <ul style="list-style-type: none"> • Added IRB 1200 and 8700 to lists of robots in different places in the manual. • Changed recommended line fusing for some robots at low voltage. • Added section Installation of drive system fans with temperature sensors on page 191. • Simplified procedure in section Replacement of fieldbus adapter in the computer unit on page 251.
G	<p>Release 16.1/RW 6.03.</p> <ul style="list-style-type: none"> • Caution about routing cables added in General on page 62. • Section Connection of drive module on page 106 added. • Added section Installing the Safety module DSQC1015 for SafeMove on page 168.
H	<p>Release 16.2.</p> <ul style="list-style-type: none"> • Added information that function tests should be performed after replacing a component. • Changes in the article names for some spare parts. • Updated cable list with revised option numbers in section Cables customer power/customer signal on page 343. • Removed section Refurbish. • Minor corrections.
J	<p>Release 17.1.</p> <ul style="list-style-type: none"> • Added sections Function test of reduced speed control on page 224, and About emergency stop on page 31. • Updated descriptions of stops in section Protective stop and emergency stop on page 29. • Updated section Safety data on page 20. • Updated list of labels in section Safety symbols on controller labels on page 26. • New computer unit DSQC1024 is introduced, see Computer unit parts on page 331. • Added limitation about SafeMove in section Connection of Drive Module Disconnect, by limit switch on page 108. • Minor corrections.

Continues on next page

Revision	Description
K	<p>Release 17.2.</p> <ul style="list-style-type: none"> • Updated list of applicable standards. • Updated section Connecting cables to the controller on page 62. • Added section Power supply system requirements on page 69. • Added sections Scalable I/O devices on page 127, Installation of Scalable I/O devices on page 139 and Scalable I/O devices on page 330. • Clarified the existing information in sections DeviceNet I/O units on page 129 and Installation of DeviceNet I/O, Gateways and encoder interface units, IRC5 on page 142. • Updated spare parts for bleeders, see Miscellaneous parts on page 332. • Removed all references to computer unit DSQC1024. • Minor corrections. • Updated section Installation of additional Drive Module on page 187.
L	<p>Release 18.1.</p> <ul style="list-style-type: none"> • Added cautions about not using external power in section Installing the Safety module DSQC1015 for SafeMove on page 168. • Updated to correct and consistent naming convention: DSQC1015 is called Safety module. • Added section FlexPendant parts on page 334. • Safety section restructured. • Added section about transformers to Connecting power supply to the controller on page 72. • Added information about disposal of storage media. • Clarified the limitations for Isolated Lan 3 in the section Isolated LAN 3 or LAN 3 as part of the private network (only for RobotWare 6.01 and later) on page 99.
M	<p>Release 18.2.</p> <ul style="list-style-type: none"> • Added note in section Connection of ES1/ES2 on panel unit on page 86, about emergency stop signals for controller with safety module. • Added information about cables for IRB 120 in section Cables customer power/customer signal on page 343. • New computer unit DSQC1024 added, see Computer unit parts on page 331. • Added note in section Replacement of SD-card memory in computer unit on page 259, that SD-card from DSQC1018 cannot be used in DSQC1024.
N	<p>Published in release 19B. The following updates are made in this revision:</p> <ul style="list-style-type: none"> • Updated spare parts numbers for manipulator cables. • New chapters added: Conveyor tracking module on page 131 and Installation of conveyor tracking module on page 144 • Outer dimensions for local I/O units added in section Scalable I/O devices on page 330. • Added information in Connecting cables to the controller on page 62. • Added information about delays on safety inputs in Protective stop and emergency stop on page 29.
P	<p>Published in release 19C. The following updates are made in this revision:</p> <ul style="list-style-type: none"> • Added information about FlexPendant cables, see Handling the FlexPendant cables on page 92.
Q	<p>Published in release 20B. The following updates are made in this revision:</p> <ul style="list-style-type: none"> • Information regarding power supply system requirements has been improved in sections Isolation transformer on page 70 and Mains line filter on page 71.

Revision	Description
R	Published in release 20D. The following updates are made in this revision: <ul style="list-style-type: none"> SD card 3HAC061416-003 that is used with computer DSQC1024 added in spare part list for Computer unit parts on page 331. Article numbers for signal cables updated in Manipulator cables on page 336. Added information that the door must be closed, see Protection class on page 48.
S	Published in release 21A. The following updates are made in this revision: <ul style="list-style-type: none"> Minor corrections in section Connectors on the computer unit on page 97. Local I/O replaced by Scalable I/O in entire manual. Information added about China RoHS, see Environmental information on page 314. Spare part numbers corrected for manipulators IRB 1600 and 2400 in section Manipulator cables on page 336.
T	Published in release 21B. The following updates are made in this revision: <ul style="list-style-type: none"> Added note about rated voltage and rated current, see Connecting power supply to the controller on page 72. Added a new section on Closing the Automatic Stop circuit, see Closing the Automatic Stop circuit.
U	Published in release 21C. The following updates are made in this revision: <ul style="list-style-type: none"> The reference to the Euromap circuit diagram is updated to new article number. Added IRB 390, see Line fusing on page 73. Added information, see AC current in CP/CS on page 63. Added new type of residual current circuit breaker (CDH440D), see Connecting power supply to the controller.
V	Published in release 21D. The following updates are made in this revision: <ul style="list-style-type: none"> Caution when connecting motor cooling fan connectors added. See Installation of cooling fan harness axis 1 and 2. Updated safety data.
W	Published in release 22A. The following updates are made in this revision: <ul style="list-style-type: none"> Updated information about humidity, see Operating conditions on page 47 and Storage conditions on page 47. Added note about networks and Connected Services, see Isolated LAN 3 or LAN 3 as part of the private network (only for RobotWare 6.01 and later) on page 99. New Ethernet switch, see Replacement of Ethernet switch on page 301. Process module installation kit is updated, see Installation kit on page 189.
X	Published in release 22C. The following updates are made in this revision: <ul style="list-style-type: none"> Added note that decommissioning shall be preceded by a risk assessment. The rating label on the controller is changed to <i>full load current</i>.
Y	Published in release 22D. The following updates are made in this revision: <ul style="list-style-type: none"> Added information about a new version of the FlexPendant. Minor corrections in section Manipulator cables on page 336. Added section Open source and 3rd party components on page 325.
Z	Published in release 23A. The following updates are made in this revision: <ul style="list-style-type: none"> Corrected spare part number for the FlexPendant holder. Minor corrections.

Continues on next page

Revision	Description
AA	Published in release 23B. The following updates are made in this revision: <ul style="list-style-type: none">• Safety data updated.• Added signal and power cables for IRB 6790.
AB	Published in release 23C. The following updates are made in this revision: <ul style="list-style-type: none">• Spart parts updated in section Controller parts on page 327.
AC	Published in release 23D. The following updates are made in this revision: <ul style="list-style-type: none">• Spart part for main computer DSQC1094 added in section Controller parts on page 327.
AD	Published in release 24A. The following updates are made in this revision: <ul style="list-style-type: none">• Section Installing the mains connections cable added.• Information about Ethernet Switch updated in Controller parts on page 327.• Information about SD card updated in Computer unit parts on page 331.
AE	Published in release 24C. The following updates are made in this revision: <ul style="list-style-type: none">• Minor updates in Configuration of the drive system on page 118 and Installation of additional drive units on page 180.
AF	Published in release 24D. The following updates are made in this revision: Minor updates in Rated voltage and current on page 72 and Line fusing on page 73 .
AG	Published in release R25.2. The following updates are made in this revision: <ul style="list-style-type: none">• New article number for the FlexPendant spare part.
AH	Published in release R25.3. The following updates are made in this revision: <ul style="list-style-type: none">• Power cables for IRB 390 updated in Manipulator cables on page 336.• Company name updated to reflect current legal entities.• Updated portal name from myABB to ABB Robotics One.

Product documentation

Categories for user documentation from ABB Robotics

The user documentation from ABB Robotics is divided into a number of categories. This listing is based on the type of information in the documents, regardless of whether the products are standard or optional.



Tip

All documents can be found via ABB Robotics One, <https://one.robots.abb.com/en/knowledge-hub>.

Product manuals

Manipulators, controllers, DressPack, and most other hardware is delivered with a **Product manual** that generally contains:

- Safety information.
- Installation and commissioning (descriptions of mechanical installation or electrical connections).
- Maintenance (descriptions of all required preventive maintenance procedures including intervals and expected life time of parts).
- Repair (descriptions of all recommended repair procedures including spare parts).
- Calibration.
- Troubleshooting.
- Decommissioning.
- Reference information (safety standards, unit conversions, screw joints, lists of tools).
- Spare parts list with corresponding figures (or references to separate spare parts lists).
- References to circuit diagrams.

Technical reference manuals

The technical reference manuals describe reference information for robotics products, for example lubrication, the RAPID language, and system parameters.

Application manuals

Specific applications (for example software or hardware options) are described in **Application manuals**. An application manual can describe one or several applications.

An application manual generally contains information about:

- The purpose of the application (what it does and when it is useful).
- What is included (for example cables, I/O boards, RAPID instructions, system parameters, software).
- How to install included or required hardware.

Continues on next page

Continued

- How to use the application.
- Examples of how to use the application.

Operating manuals

The operating manuals describe hands-on handling of the products. The manuals are aimed at those having first-hand operational contact with the product, that is production cell operators, programmers, and troubleshooters.

Network security

Network security

This product is designed to be connected to and to communicate information and data via a network interface. It is your sole responsibility to provide, and continuously ensure, a secure connection between the product and to your network or any other network (as the case may be).

You shall establish and maintain any appropriate measures (such as, but not limited to, the installation of firewalls, application of authentication measures, encryption of data, installation of anti-virus programs, etc) to protect the product, the network, its system and the interface against any kind of security breaches, unauthorized access, interference, intrusion, leakage and/or theft of data or information. ABB Ltd and its entities are not liable for damage and/or loss related to such security breaches, any unauthorized access, interference, intrusion, leakage and/or theft of data or information.

This page is intentionally left blank

1 Safety

1.1 Safety information

1.1.1 Limitation of liability

Limitation of liability

Any information given in this manual regarding safety must not be construed as a warranty by ABB that the industrial robot will not cause injury or damage even if all safety instructions are complied with.

The information does not cover how to design, install and operate a robot system, nor does it cover all peripheral equipment that can influence the safety of the robot system.

In particular, liability cannot be accepted if injury or damage has been caused for any of the following reasons:

- Use of the robot in other ways than intended.
- Incorrect operation or maintenance.
- Operation of the robot when the safety devices are defective, not in their intended location or in any other way not working.
- When instructions for operation and maintenance are not followed as intended.
- Non-authorized design modifications of the robot.
- Repairs on the robot and its spare parts carried out by in-experienced or non-qualified personnel.
- Foreign objects.
- Force majeure.

Spare parts and equipment

ABB supplies original spare parts and equipment which have been tested and approved for their intended use. The installation and/or use of non-original spare parts and equipment can negatively affect the safety, function, performance, and structural properties of the robot. ABB is not liable for damages caused by the use of non-original spare parts and equipment.

1 Safety

1.1.2 Safety data

1.1.2 Safety data

About this section

This chapter describes the necessary safety data required by standard EN ISO 13849-1:2015.

Prevailing directives and standards

For the use of industrial robots and how to protect personnel from being injured, special regulations must be fulfilled as described in the following directives and standards:

- Machinery Directive 2006/42/EC
 - EN ISO 10218-1:2011
 - EN ISO 13849-1:2008 (when explicitly called forth by EN ISO 10218-1:2011 as ISO 13849-1:2006)
 - EN ISO 13849-1:2015
-

Performance level and category

EN ISO 13849-1, which is a B-standard, describes the general concept of performance level (PL) and category. Each machine or machinery is potentially dangerous and can cause personal injury. Based on severity of injury and probability of accident, when using the machine, a certain level of safety performance, so called required performance level (PL_r) can be defined, where *level a* represents the lowest risk and *level e* the highest. According to this, the machine must be equipped with safety related parts, meeting the required performance level, to reduce the risk to accepted low level. As specified in EN ISO 10218-1, normally *PL d* is required for robots, but depending on the applications a higher requirement could be needed if a risk analysis will result in *PL e*.

To comply with a certain PL_r, in this case *d*, the safety related parts of the robots and controllers must be structurally designed according to specific structure categories and using reliable components.

In EN ISO 13849-1 it is in detail specified what category and components data, which must be met, to fulfill *PL d*. These are:

- Category 3, which is normally fulfilled using double channels
 - MTTF_D (Mean Time To dangerous Failure) – high
 - DC (Diagnostic Coverage) – low or medium
 - CCF (Common Cause Failures) – better than 65 scores according to Annex F
-

Performance level for ABB IRC5 controller

To verify that robots and controller comply with at least *PL d* a self assessment has been carried out and documented in a *Technical Report*. The essential conclusions are accounted for below.

The safety related parts of robot and controller are e.g. the following stop circuits:

- Enabling device
- Emergency stop on operator panel

Continues on next page

- Emergency stop on FlexPendant
- Limiting robot motion
- Protective stops
- SafeMove
- EPS
- SafeMove2

For the overall design and structure, the category 3 has been verified and meeting the requirements of CCF.

Each of the stop circuits includes different components like enabling switch, panel board, contactor board, relays etc. For each of these the $MTTF_D$ and DC have been calculated according to EN ISO 13849-1 Annex C, D and E resulting in the values as specified in the following table.

See the SISTEMA/ABB FSDT libraries for details of the safety functions.

IRC5 Single and IRC5 Panel Mounted Controller

Safety function	Calculated $MTTF_D$ [years]	DC_{avg}
Emergency stop inputs (operator panel)	112	Medium
Automatic stop input	120	Medium
General stop input	120	Medium
Superior stop input	120	Medium
Limiting switch input (without customer connection)	176	Medium
Three-position enabling device inputs	91	Medium
Emergency stop status outputs	239	Medium
Emergency stop inputs (source external)	101	Medium
SafeMove (option) (without customer connections)	58	Medium
Electronic Position Switches (option) (without customer connections)	105	Medium
SafeMove2 functions (option)		
Protective stop	370	Low
Emergency stop	370	Low
Emergency stop safe fieldbus output	370	Low
Speed supervision	370	Low
Speed supervision safe fieldbus output	370	Low
Position supervision	370	Low
Position supervision safe fieldbus output	370	Low
External power control	88	Low

Based on the values from the previous table of $MTTF_D$ values, the corresponding PFH_D can be calculated using the Annex K, table K1 of EN ISO 13849-1:2008.

These are shown in the following table.

Continues on next page

1 Safety

1.1.2 Safety data

Continued

IRC5 Single and IRC5 Panel Mounted Controller

Stop circuit	Calculated PFH _D	PL
Emergency stop inputs (operator panel)	4.29x10E-08	e
Automatic stop input	4.29x10E-08	e
General stop input	4.29x10E-08	e
Superior stop input	4.29x10E-08	e
Limiting switch input (without customer connection)	4.29x10E-08	e
Three-position enabling device inputs	4.94x10E-08	e
Emergency stop status outputs	4.29x10E-08	e
Emergency stop inputs (source external)	4.29x10E-08	e
SafeMove (option) (without customer connections)	1.03x10E-07	d
Electronic Position Switches (option)	4.29x10E-08	e
SafeMove2 functions (option)		
Protective stop	1.01x10E-07	d
Emergency stop	1.01x10E-07	d
Emergency stop safe fieldbus output	1.01x10E-07	d
Speed supervision	1.01x10E-07	d
Speed supervision safe fieldbus output	1.01x10E-07	d
Position supervision	1.01x10E-07	d
Position supervision safe fieldbus output	1.01x10E-07	d
External power control	1.35x10E-07	d

Conclusion according to EN ISO 13849-1:2015

The IRC5 controller safety system has a safety *category 3* with performance level *PL d* according to EN ISO 13849-1 using the simplified method of chapter 4.5.4 of EN ISO 13849-1 and thus fulfils the safety performance requirement of the robot safety standard EN ISO 10218-1.

The *Common Cause Failure (CCF)* is met according to the standard requirements.

1.1.3 Requirements on personnel

General

Only personnel with appropriate training are allowed to install, maintain, service, repair, and use the robot. This includes electrical, mechanical, hydraulics, pneumatics, and other hazards identified in the risk assessment.

Persons who are under the influence of alcohol, drugs or any other intoxicating substances are not allowed to install, maintain, service, repair, or use the robot.

The plant liable must make sure that the personnel is trained on the robot, and on responding to emergency or abnormal situations.

Personal protective equipment

Use personal protective equipment, as stated in the instructions.

1 Safety

1.2.1 Safety signals in the manual

1.2 Safety signals and symbols

1.2.1 Safety signals in the manual







Introduction to safety signals

This section specifies all safety signals used in the user manuals. Each signal consists of:

- A caption specifying the hazard level (DANGER, WARNING, or CAUTION) and the type of hazard.
- Instruction about how to reduce the hazard to an acceptable level.
- A brief description of remaining hazards, if not adequately reduced.

Hazard levels

The table below defines the captions specifying the hazard levels used throughout this manual.

Symbol	Designation	Significance
	DANGER	Signal word used to indicate an imminently hazardous situation which, if not avoided, will result in serious injury.
	WARNING	Signal word used to indicate a potentially hazardous situation which, if not avoided, could result in serious injury.
	ELECTRICAL SHOCK	Signal word used to indicate a potentially hazardous situation related to electrical hazards which, if not avoided, could result in serious injury.
	CAUTION	Signal word used to indicate a potentially hazardous situation which, if not avoided, could result in slight injury.
	ELECTROSTATIC DISCHARGE (ESD)	Signal word used to indicate a potentially hazardous situation which, if not avoided, could result in severe damage to the product.
	NOTE	Signal word used to indicate important facts and conditions.

Continues on next page

Symbol	Designation	Significance
	TIP	Signal word used to indicate where to find additional information or how to do an operation in an easier way.

1 Safety

1.2.2 Safety symbols on controller labels

1.2.2 Safety symbols on controller labels

Introduction to safety symbols

Both the manipulator and the controller are marked with labels containing safety symbols and important information about the product. The purpose of the labels is to ensure personal safety for all personnel handling the robot, for example during installation, service, or operation.

The safety symbols are language independent, they only use graphics. The information labels contain information in text. See [Symbols and information on labels on page 26](#).



Note



The safety and information labels on the product must be observed.

Symbols and information on labels







Note

The descriptions in this section are generic, the labels can contain additional information such as values.

Label	Description
 xx1400001152	Read the user manual before use.
 xx1800000835	CE label
 xx1400002060	UR certified (component)

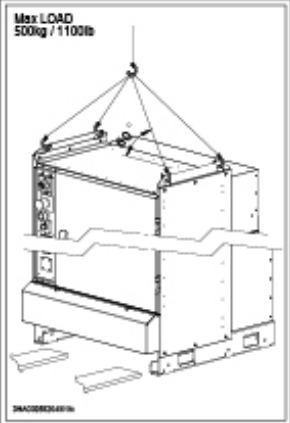
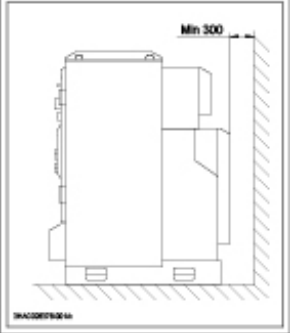



Continues on next page

Label	Description
 <p>xx1400002061</p>	<p>UL certified (robot with controller)</p>
 <p>xx1400001163</p>	<p>Rating label (example)</p>
 <p>xx1400001157</p>	<p>Lifting instruction for the IRC5 controller.</p>
 <p>xx1400001155</p>	<p>Required installation space.</p>
 <p>xx1400001151</p>	<p>Electrical shock</p>

1 Safety

1.2.2 Safety symbols on controller labels

Continued

Label	Description
 <p>xx1400001161</p>	<p>Disconnect incoming mains before servicing the controller.</p>
 <p>xx1400001160</p>	<p>Disconnect incoming mains before servicing the controller (only for welding equipment).</p>
 <p>xx1700000354</p>	<p>Disconnect incoming mains before servicing the controller (for controllers without UL mains switch).</p>
 <p>xx1400001156</p>	<p>High voltage inside the module even if the main switch is in the OFF position.</p>
 <p>xx1400001162</p>	<p>ESD sensitive components inside the controller.</p>

1.3 Robot stopping functions

1.3.1 Protective stop and emergency stop

Robot stopping functions

The robot has protective and emergency stop functions (stop category 0 or 1, in accordance with IEC 60204-1).

Stop category 0	As defined in IEC 60204-1, stopping by immediate removal of power to the machine actuators.
Stop category 1	As defined in IEC 60204-1, a controlled stop with power available to the machine actuators to achieve the stop and then removal of power when the stop is achieved.

A stop function, protective or emergency stop, has a default setting for the stop category, see [Inputs to initiate a protective stop or an emergency stop on page 29](#).

The default stop category for a protective or emergency stop can be re-configured. Activation of external safety rated devices, connected to the robot controller through dedicated discrete safety inputs or safety protocols, will initiate these stop functions.

Inputs to initiate a protective stop or an emergency stop

Inputs to initiate a stop function	Description	Default stop category ⁱ	Stop category reconfigurable
Emergency Stop (ES)	Input to initiate the emergency stop function. The <i>Emergency Stop</i> function is initiated in both automatic and manual mode.	Stop category 0 For deviations, see the product manual for the manipulator.	Yes
Automatic Stop (AS)	Input to initiate the protective stop function <i>Automatic Stop</i> . The <i>Automatic Stop</i> function is only initiated in automatic mode.	Stop category 1	Yes
General Stop (GS)	Input to initiate the protective stop function <i>General Stop</i> . The <i>General Stop</i> function is initiated in both manual mode and automatic mode.	Stop category 1	Yes
	Inputs to initiate the protective stop function. The protective stop function can be configured as <i>Automatic Stop</i> or <i>General Stop</i> . <i>Automatic Stop</i> is only initiated in automatic mode. <i>General Stop</i> is initiated in both manual mode and automatic mode. ⁱⁱ	Stop category 1 For deviations, see the product manuals for the controller and the manipulator.	Yes
Superior Stop (SS)	Input to initiate the superior stop function. The <i>Superior Stop</i> function is initiated in both manual mode and automatic mode.	Stop category 1	Yes

ⁱ Stop category 1 is deactivated by responsive jogging in manual reduced speed mode by default. Stop category 1 can be deactivated by changing the parameter Jog Mode from *Responsive* to *Standard*.

Continues on next page

1 Safety

1.3.1 Protective stop and emergency stop

Continued

For more information about Responsive jogging, see *AM Functional safety and SafeMove 3HAC066559-001*.

- ii Depending on controller variant, there can be one or two inputs for the protective stop function. See the product manual for the robot controller.

For example, a safety rated output from a presence sensing device, connected to AS / GS, a dedicated discrete protective stop input on the robot controller, will when the protective stop function is configured as Automatic Stop (AS) initiate the protective stop function in automatic mode only.

The emergency stop function is a complementary protective measure and shall not be applied as a substitute for safeguarding measures or safety functions.



Note

For IRC5, a safety input on the panel board that is initiated, must remain active for at least 1.5 s.

Stop category configuration for IRC5

The stop category for the safety input can be configured, see *Technical reference manual - System parameters*.

Safety inputs	System parameter Function	Description
Emergency Stop	<i>SoftES</i>	<i>SoftES</i> is used to configure the emergency stop in automatic and manual mode. The default configuration is <i>FALSE</i> (stop category 0).
Automatic Stop	<i>SoftAS</i>	<i>SoftAS</i> can be used to configure the protective stop in automatic mode either as stop category 0 or category 1. The default configuration is <i>TRUE</i> (stop category 1).
General Stop	<i>SoftGS</i>	<i>SoftGS</i> can be used to configure the protective stop in automatic and manual mode, either as stop category 0 or category 1. The default configuration is <i>TRUE</i> (stop category 1).
Superior Stop	<i>SoftSS</i>	<i>SoftSS</i> can be used to configure the protective stop in automatic and manual mode, either as stop category 0 or category 1. The default configuration is <i>TRUE</i> (stop category 1).

1.3.2 About emergency stop

The emergency stop

The purpose of the emergency stop function is to avert actual or impending emergency situations arising from the behavior of persons or from an unexpected hazardous event.

The emergency stop function is to be initiated by a single human action.

The emergency stop function is a complementary protective measure and shall not be applied as a substitute for safeguarding measures and other functions or safety functions.

The effect of an activated emergency stop device is sustained until the actuator of the emergency stop device has been disengaged. This disengagement is only possible by an intentional human action on the device where the command has been initiated. The disengagement of the emergency stop device shall not restart the machinery but only permit restarting.



Note

The emergency stop device on the FlexPendant is operational when the robot is powered. Indicators to be used to verify that the robot is powered are the main switch on the cabinet or the LED indicator on the cabinet when robot is in Motors On Mode.

Recover from emergency stop

- 1 Inspect the machinery in order to detect the reason for the emergency stop device actuation.
- 2 Locate and disengage the emergency stop device or devices that initiated the emergency stop function.

1.3.3 Enabling device and hold-to-run functionality

Three-position enabling device



CAUTION

The person using the three-position enabling device is responsible to observe the safeguarded space for hazards due to robot motion and any other hazards related to the robot.

The three-position enabling device is located on the FlexPendant. When continuously held in center-enabled position, the three-position enabling device will permit robot motion and any hazards controlled by the robot. Release of or compression past the center-enabled position will stop the robot motion.



CAUTION

For safe use of the three-position enabling device, the following must be implemented:

- The three-position enabling device must never be rendered inoperational in any way.
- If there is a need to enter safeguarded space, always bring the FlexPendant. This is to enforce single point of control.

Hold-to-run function in manual high speed mode

The hold-to-run function for manual high speed allows movement in conjunction with the three-position enabling device when the button connected to the function is actuated manually. This hold-to-run function can only be used in manual high speed mode. In case of hazard, release or compress the three-position enabling device.

How to use the hold-to-run function for manual high speed mode is described in the operating manual for the controller.

1.4 Robot operating modes

1.4.1 About the manual mode

The manual mode

Manual mode is a control state that allows for the direct control by an operator. The operator will through positioning the three-position enabling device to the center-position allow for movement of the manipulator.

There are two manual modes:

- Manual reduced speed
- Manual high speed (optional)

Safeguard mechanisms

Protective stop function initiated by

- Three-position enabling device (release of or compression past the center-enabled position)
- General Stop, GS

The mode manual reduced speed

The mode manual reduced speed, is used for jogging, teaching, programming and program verification of the robot; it may be the mode selected when performing some maintenance tasks.

In manual reduced speed mode the movement of the TCP is limited to 250 mm/s. In addition, there is a limitation on the maximum allowed speed for each axis.

Manual control of the robot from inside the safeguarded space shall be performed through the FlexPendant.



WARNING

Wherever possible, the manual mode of operation shall be performed with all persons outside the safeguarded space.

Tasks normally performed in mode manual reduced speed

The following tasks are normally performed in manual reduced speed mode.

- Set or reset I/O signals
- Creating and editing RAPID programs
- Modify system parameter values
- Starting, stepping, and stopping program execution
- Jog the manipulator
- Teach or tune programmed manipulator positions

The mode manual high speed

The mode manual high speed, is used for program verification only.

Continues on next page

1 Safety

1.4.1 About the manual mode

Continued

The three-position enabling switch must be pressed to the center-position and the hold-to-run button must be pressed to allow start of program execution, for example, execute movement instructions.

In manual high speed, the initial speed of the movement, does not exceed 250 mm/s, that is limited to a percentage of the programmed speed. The speed can be manually adjusted in steps up to the programmed speed.

When the three-position enabling device is released or fully compressed, the speed is reset to the initial speed, that is, not exceeding 250 mm/s.



WARNING

Wherever possible, the manual mode of operation shall be performed with all persons outside the safeguarded space.



Note

The restricted space shall be provided when the robot is foreseen to be used in manual high speed.

Tasks normally performed in mode manual high speed

The following tasks are normally performed in manual high speed mode.

- Program verification
- Setting program pointer (to Main, to routine, to cursor, to service routine, etc.)
- Starting and stopping program execution
- Stepping program execution
- Manually adjusting speed (0–100%)

1.4.2 About the automatic mode

The automatic mode

Automatic mode is an operating mode in which the robot operates in accordance with the task program(s) and therefore not in manual control by an operator.

Tasks normally performed in automatic mode

The following tasks are typically performed in automatic mode:

- Start and stop of program execution.
- Increase or decrease the speed in between zero and programmed speed.
- Restore backups. Only possible when robot is at stop.
- Load, start, stop, and modify RAPID programs through remote clients.

Safeguard mechanisms

Protective stop function initiated by

- Automatic Stop, AS
- General Stop, GS
- Superior Stop, SS



Note

Prior to allowing the robot to operate in automatic mode, ensure that any suspended safeguards, are returned to full functionality.

1 Safety

1.5 Safety during installation and commissioning

1.5 Safety during installation and commissioning

National or regional regulations

The integrator of the robot system is responsible for the safety of the robot system.

The integrator is responsible that the robot system is designed and installed in accordance with the safety requirements set forth in the applicable national and regional standards and regulations.

The integrator of the robot system is required to perform a risk assessment.

Layout

The robot integrated to a robot system shall be designed to allow safe access to all spaces during installation, operation, maintenance, and repair.

If robot movement can be initiated from an external control panel then an emergency stop must also be available.

If the manipulator is delivered with mechanical stops, these can be used for reducing the working space.

A perimeter safeguarding, for example a fence, shall be dimensioned to withstand the following:

- The force of the manipulator.
- The force of the load handled by the robot if dropped or released at maximum speed.
- The maximum possible impact caused by a breaking or malfunctioning rotating tool or other device fitted to the robot.

The maximum TCP speed and the maximum velocity of the robot axes are detailed in the section *Robot motion* in the product specification for the respective manipulator.

Consider exposure to hazards, such as slipping, tripping, and falling.

Hazards due to the working position and posture for a person working with or near the robot shall be considered.

Hazards due to noise emission from the robot needs to be considered.

Consider hazards from other equipment in the robot system, for example, that guards remain active until identified hazards are reduced to an acceptable level.

Allergenic material

See [Environmental information on page 314](#) for specification of allergenic materials in the product, if any.

Securing the robot to the foundation

The robot must be properly fixed to its foundation/support, as described in the respective product manual.

When the robot is installed at a height, hanging, or other than mounted directly on the floor, there will be additional hazards.

Continues on next page

Using lifting accessories and other external equipment

Ensure that all equipment used during installation, service and all handling of the robot are in correct condition for the intended use.

Electrical safety

Incoming mains must be installed to fulfil national regulations.

The power supply wiring to the robot must be sufficiently fused and if necessary, it must be possible to disconnect it manually from the mains power.

The power to the robot must be turned off with the main switch and the mains power disconnected when performing work inside the controller cabinet. Lock and tag shall be considered.

Hazards due to stored electrical energy in the controller must be considered.

Harnesses between controller and manipulator shall be fixed and protected to avoid tripping and wear.

Wherever possible, power on/off or rebooting the robot controller shall be performed with all persons outside the safeguarded space.



Note

Use a CARBON DIOXIDE (CO₂) extinguisher in the event of a fire in the robot.



ELECTRICAL SHOCK

The controller mains power switch shall be disabled before disconnecting the controller power cable from the mains supply.

Safety devices

The integrator is responsible for that the safety devices necessary to protect people working with the robot system are designed and installed correctly.

When integrating the robot with external devices to a robot system:

- The integrator of the robot system must ensure that emergency stop functions are interlocked in accordance with applicable standards.
- The integrator of the robot system must ensure that safety functions are interlocked in accordance with applicable standards.

Other hazards

A robot may perform unexpected limited movement.



WARNING

Manipulator movements can cause serious injuries on users and may damage equipment.

The risk assessment should also consider other hazards arising from the application, such as, but not limited to:

- Water

Continues on next page

1 Safety

1.5 Safety during installation and commissioning

Continued

- Compressed air
- Hydraulics

End-effector hazards require particular attention for applications which involve close human collaboration with the robot.

Verify the safety functions

Before the robot system is put into operation, verify that the safety functions are working as intended and that any remaining hazards identified in the risk assessment are mitigated to an acceptable level.

1.6 Safety during operation



ELECTRICAL SHOCK

The controller mains power switch shall be disabled before disconnecting the controller power cable from the mains supply.



WARNING

Personnel shall wear close-fitting clothing with no loose ends or dangling elements when operating or working in proximity to the manipulator to eliminate the risk of entanglement with moving parts.

Automatic operation

Verify the application in the operating mode manual reduced speed, before changing mode to automatic and initiating automatic operation.

Lock and change of operating mode

To prevent hazard, it is the responsibility of the integrator to make sure that keys used to lock or change the operating mode are handled only by authorized personnel.

An IRC5 controller with a physical key for the mode selector, is designed so that the key fits on all IRC5 controllers, unless unique keys are ordered.

Safety devices not in use

Safety devices that are not connected to the robot or robot system cannot initiate a protective or emergency stop. These must be stored out of sight so that they cannot be mistaken for being in use.

1 Safety

1.7 Safety during maintenance and repair

1.7 Safety during maintenance and repair

General



ELECTRICAL SHOCK

The controller mains power switch shall be disabled before disconnecting the controller power cable from the mains supply.

Corrective maintenance must only be carried out by personnel trained on the robot. Maintenance or repair must be done with all electrical, pneumatic, and hydraulic power switched off, that is, no remaining hazards.

Never use the robot as a ladder, which means, do not climb on the controller, manipulator, including motors, or other parts. There are hazards of slipping and falling. The robot might be damaged.

Make sure that there are no tools, loose screws, turnings, or other unexpected parts remaining after maintenance or repair work.

When the work is completed, verify that the safety functions are working as intended.

Hot surfaces

Surfaces can be hot after running the robot, and touching these may result in burns. Allow the surfaces to cool down before maintenance or repair.

Hazards related to batteries

Under rated conditions, the electrode materials and liquid electrolyte in the batteries are sealed and not exposed to the outside.

There is a hazard in case of abuse (mechanical, thermal, electrical) which leads to the activation of safety valves and/or the rupture of the battery container. As a result under certain circumstances, electrolyte leakage, electrode materials reaction with moisture/water or battery vent/explosion/fire may follow.

Do not short circuit, recharge, puncture, incinerate, crush, immerse, force discharge or expose to temperatures above the declared operating temperature range of the product. Risk of fire or explosion.

Operating temperatures are listed in [Operating conditions on page 47](#).

See safety instructions for the batteries in *Material/product safety data sheet - Battery pack (3HAC043118-001)*.

Related information

See also the safety information related to installation and operation.

1.8 Safety during troubleshooting

General

When troubleshooting requires work with power switched on, special considerations must be taken:

- Safety circuits might be muted or disconnected.
- Electrical parts must be considered as *live*.
- The manipulator can move unexpectedly at any time.



DANGER

Troubleshooting on the controller while powered on must be performed by personnel trained by ABB or by ABB field engineers.



ELECTRICAL SHOCK

The controller mains power switch shall be disabled before disconnecting the controller power cable from the mains supply.

A risk assessment must be done to address both robot and robot system specific hazards.

Related information

See also the safety information related to installation, operation, maintenance, and repair.

1 Safety

1.9 Safety during decommissioning

1.9 Safety during decommissioning

General

See section [Decommissioning on page 313](#).

If the robot is decommissioned for storage, take extra precaution to reset safety devices to delivery status.



ELECTRICAL SHOCK

The controller mains power switch shall be disabled before disconnecting the controller power cable from the mains supply.

2 Installation and commissioning

2.1 Overview

General

The ABB IRC5 controller has all components in one cabinet.

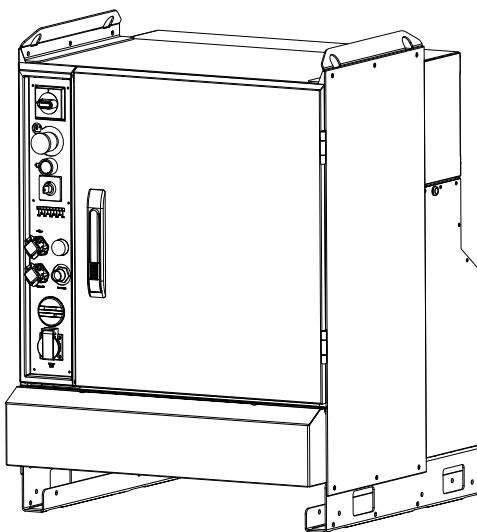

xx130000607



Note

When replacing a unit in the controller, report the following data to ABB, for both the replaced unit and the replacement unit:

- the serial number
- article number
- revision

This is particularly important for the safety equipment to maintain the safety integrity of the installation.

Continues on next page

2 Installation and commissioning

2.1 Overview

Continued

Wrist strap button

The location of the wrist strap button is shown in the following illustration.

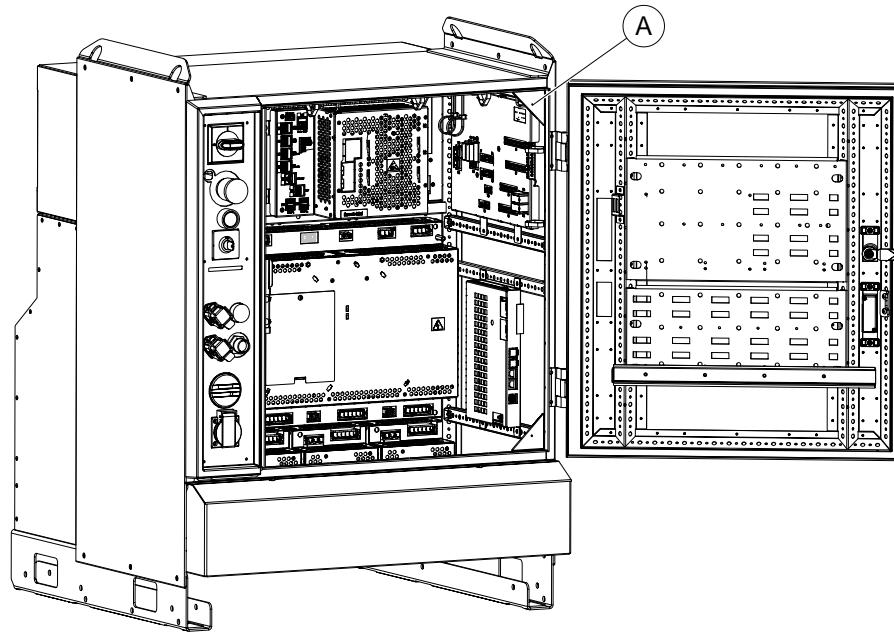

A	Wrist strap button
---	--------------------

2.2 Installation activities

Prerequisites

The following section details the main steps on how to unload, transport, install, and connect the IRC5 controller

Overview of the installation

	Action	Detailed in
1	Unpack the IRC5 controller.	How to lift, unpack and transport the IRC5 controller is detailed in section Lifting the controller cabinet on page 46 and Unpacking the controller on page 47
2	Install the IRC5 Controller.	Bolting down the controller on page 51
3	Connect the manipulator to the IRC5 controller.	Connecting the manipulator to the controller on page 78
4	Connect power supply to the IRC5 controller.	Connecting power supply to the controller on page 72
5	Connect the FlexPendant to the IRC5 controller.	Connecting a FlexPendant on page 91
6	Install the safety functions, for example, the emergency stop.	Connection of the MOTORS ON/MOTORS OFF circuit on page 83 Connection of external safety relay on page 81 Closing the Automatic Stop circuit on page 82
7	Miscellaneous connections.	How to connect buses, for example DeviceNet, is detailed in the respective application manual. How to connect I/O units to the IRC5 controller is detailed in section Installation of DeviceNet I/O, Gateways and encoder interface units, IRC5 on page 142 . How to connect a PC to the controller is described in manual <i>Operating manual - RobotStudio</i> . How to connect to a network is detailed in section Connectors on the computer unit on page 97 .
8	Install add-ons (optional).	Installation of add-ons on page 133
9	When the installation is complete, perform the function tests in section Function tests on page 213 to verify that the safety features work properly.	

2 Installation and commissioning

2.3.1 Lifting the controller cabinet

2.3 Transporting and handling

2.3.1 Lifting the controller cabinet

Lifting device

Use the two lifting eyes or a fork lift when lifting the IRC5 controller, as shown below.

The following figure shows the maximum angle between the lifting straps when lifting the controller. The weight of the controller module is detailed in section [Unpacking the controller on page 47](#).

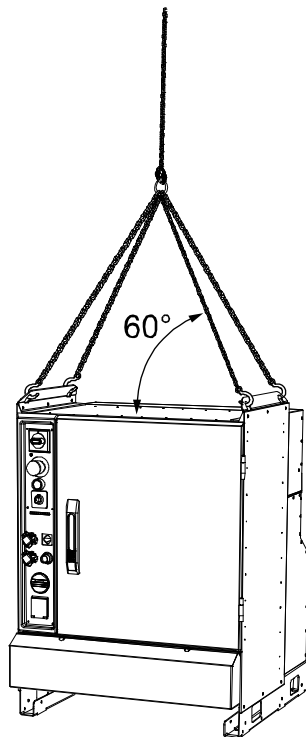

xx0500001847

2.3.2 Unpacking the controller

General

Read the safety regulations and other instructions before unpacking the controller, see [Safety on page 19](#).

The installation must be done by qualified installation personnel and should conform to all national and local codes.

When unpacking the cabinet, inspect that it was not damaged during transport.



Note

If the controller is going to be stored before unpacking and installation, read the following information regarding storage conditions.

Storage conditions

The table below shows the recommended storage conditions for the IRC5 controller:

Parameter	Value
Min. ambient temperature	-25 °C (-13 °F)
Max. ambient temperature	+55 °C (+131 °F)
Max. ambient temperature (short periods, max 24 h)	+70 °C (+158 °F)

After storage, the operating conditions inside the controller must be met for at least 6 hours before switching on the controller (see [Operating conditions on page 47](#)).

The robot controller shall only be stored indoors, in an environment that is dry and dust-free. In addition, wind, temperature fluctuations, and condensation shall be avoided.

Operating conditions

The table below shows the allowed operating conditions for the IRC5 controller:

Parameter	Value
Min. ambient temperature	0 °C (32 °F)
Max. ambient temperature	+45 °C (113 °F)
Max. ambient temperature (option)	+52 °C (125.6 °F)



Note

The humidity conditions shall apply with the environmental conditions EN 60721-3-3, climatic class 3K3. For temperatures 0-30 °C, the relative humidity must not exceed 85%. For temperatures exceeding 30 °C, the absolute humidity must not exceed 25g/m³.

If the environmental conditions in EN 60721-3-3, climatic class 3K3, are not possible to meet at the installation site, desiccant bags can be placed inside the controller to achieve corresponding conditions. The desiccant bags must be replaced regularly to maintain approved operating conditions.

Continues on next page

2 Installation and commissioning

2.3.2 Unpacking the controller

Continued

Weight of controller

The table below shows the weight for the IRC5 controller:

Controller	Part	Weight
IRC5	Complete controller	max. 150 kg
	Extra drive module	100-130 kg

Protection class

The table below shows the protection classes for the IRC5 controller and the FlexPendant:

Equipment	Protection class
IRC5 controller electronics	IP54
IRC5 controller air cooling ducts	IP33
FlexPendant	IP54

The cabinet must be closed and sealed when no internal access is required.

If the cabinet is not properly closed and sealed (door and cable grommets), it does not comply with the protection class (IP54) and may affect the following:

- The electromagnetic compatibility (EMC) is affected
- Units inside the cabinet are exposed to dust or moisture. Especially important in cases with high heat and humidity, or much pollution.



Note

To comply with IP54, all openings to the controller cabinet must be sealed. This includes unconnected connectors which must be fitted with covers.

2.3.3 The unit is sensitive to ESD

Description

ESD (electrostatic discharge) is the transfer of electrical static charge between two bodies at different potentials, either through direct contact or through an induced electrical field. When handling parts or their containers, personnel not grounded may potentially transfer high static charges. This discharge may destroy sensitive electronics.

Safe handling

Use one of the following alternatives:

- Use a wrist strap. The wrist strap button is located inside the controller.
Wrist straps must be tested frequently to ensure that they are not damaged and are operating correctly.
- Use an ESD protective floor mat.
The mat must be grounded through a current-limiting resistor.
- Use a dissipative table mat.
The mat should provide a controlled discharge of static voltages and must be grounded.

Wrist strap button

The location of the wrist strap button is shown in the following illustration.

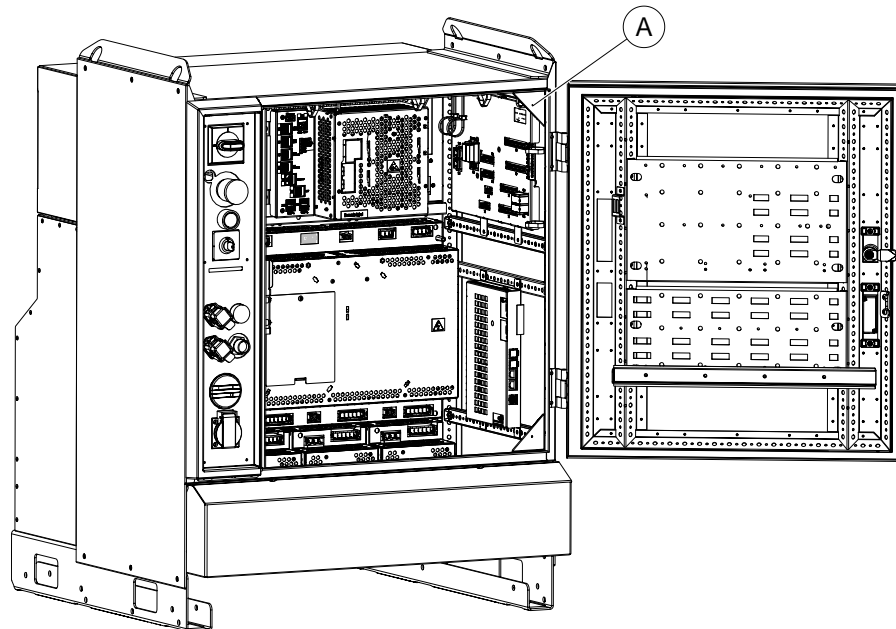

A	Wrist strap button
---	--------------------

There is an additional wrist strap button on the main computer.

2 Installation and commissioning

2.4.1 Required installation space, IRC5 Controller

2.4 On-site installation

2.4.1 Required installation space, IRC5 Controller

Dimensions

The figure below shows the required installation space for the IRC5 controller.

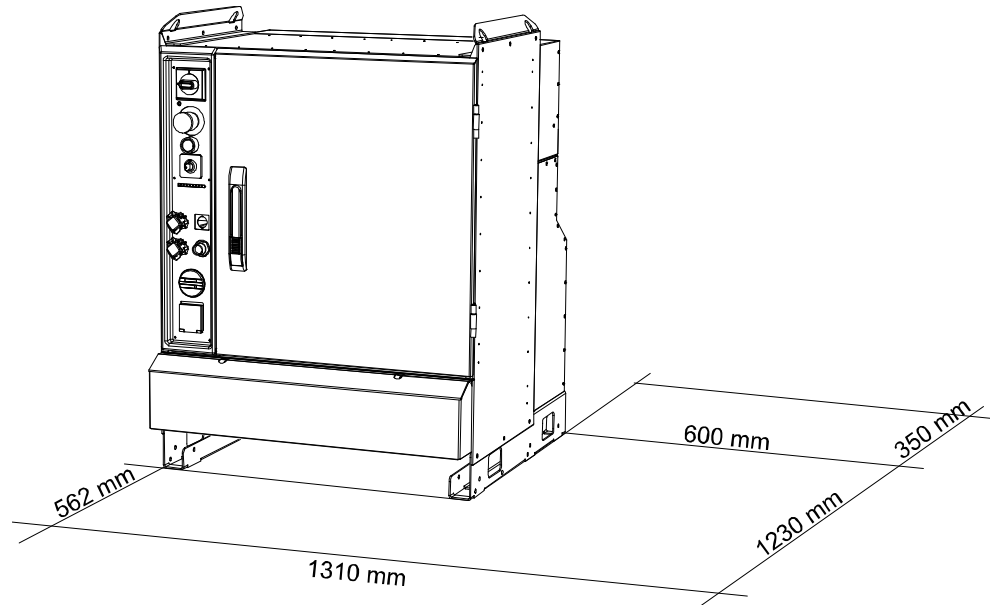

xx0500001848



Note

The free space on the right hand side of the controller is required to allow opening the door a full 180° and to access the optional moist dust filter.



Note

The air distance 300 mm on the back of the controller is required to allow inspection and replacement of the optional moist dust filter and ensure proper cooling.



Note

Do not place customer cables over the moist dust filters on the back of the controller. This makes it difficult to inspect and replace the moist dust filters.

2.4.2 Bolting down the controller

Bolt pattern

The figure below shows the bolt pattern for the IRC5 controller. The diameter of the four bolt holes are 14 mm.

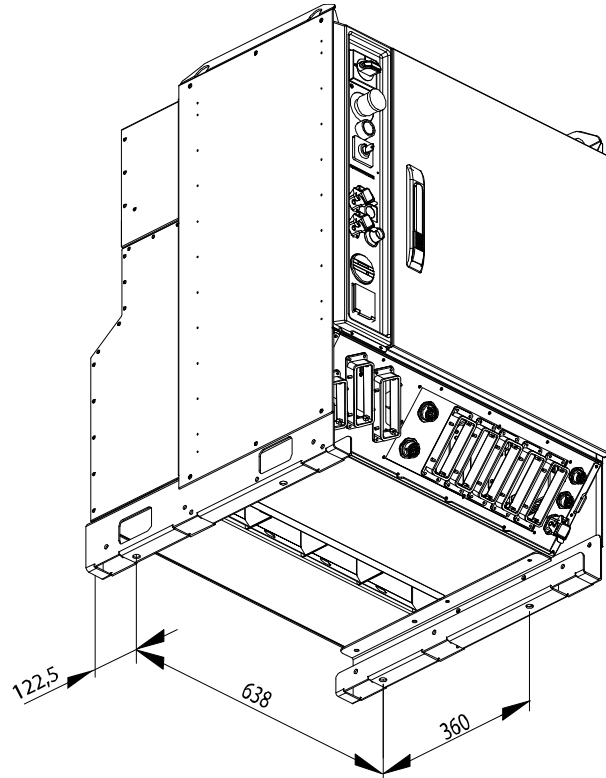

xx0500001853

2 Installation and commissioning

2.4.3 Transportation screws

2.4.3 Transportation screws

General

During transportation the connector cover is secured with two screws. The two screws must be removed before removal of the plate and connection of cables. The screws are located as shown in the illustration below.

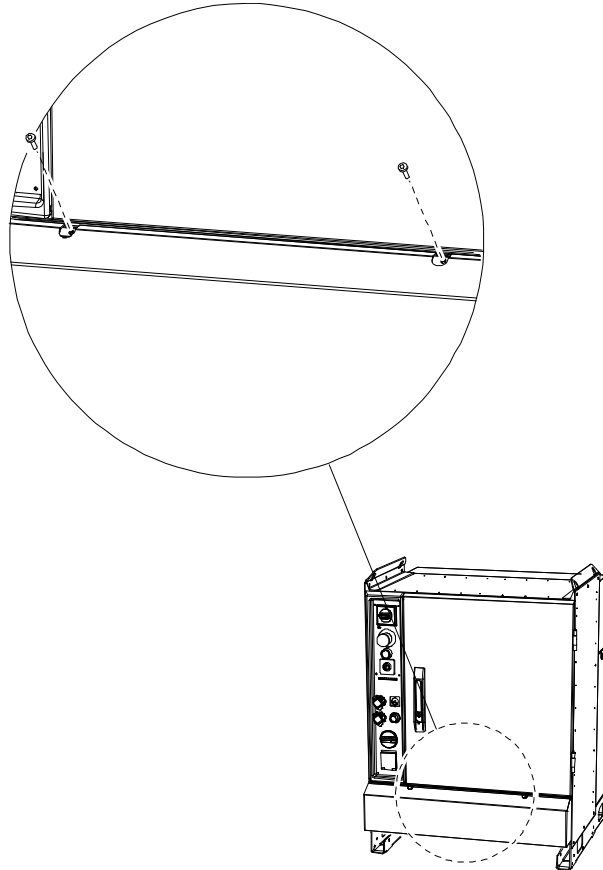

xx0500002038

2.4.4 Mounting the FlexPendant holder

Introduction

The FlexPendant holder is available in different versions, that fit different FlexPendant versions. The holder is compatible with the FlexPendant that it is delivered with.

The holder can be placed horizontally on a flat surface, for example, on top of the controller, or hanging, for example, on a door.



Note

To avoid dropping the FlexPendant from height, the holder should be placed in a comfortable working height.

Always use and store the FlexPendant in such a way that the cable does not become a tripping hazard.

When not using the device, place it so it does not accidentally fall.

Required equipment

Equipment	Note
Standard toolkit	See Standard toolkit, IRC5 on page 323
FlexPendant holder	For spare parts, see FlexPendant parts on page 334 .



Note

The FlexPendant should always be placed in the holder when it is not used and it is not allowed to use by unauthorized person.

Continues on next page

2 Installation and commissioning

2.4.4 Mounting the FlexPendant holder

Continued

Mounting kit

The FlexPendant holder is available in different versions, that fit different FlexPendant versions. The holder is compatible with the FlexPendant that it is delivered with.

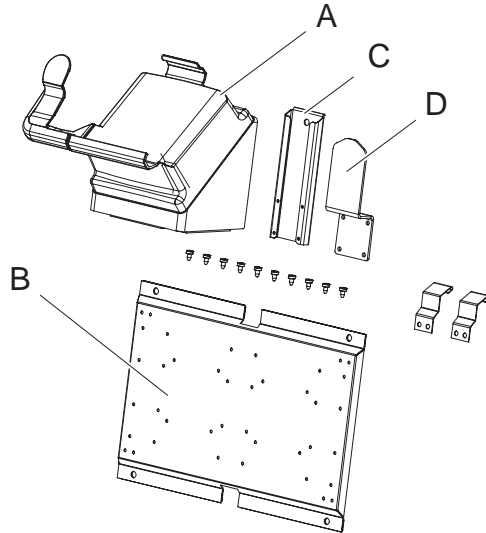

xx2200001447

A	FlexPendant holder (the appearance depends on the version of the FlexPendant)
B	Mounting plate (mounting holes \varnothing 8.5 mm (2x), distance 340 mm)
C	Cable bracket holder
D	Cable bracket

Mounting the FlexPendant holder onto a flat surface (Horizontally)

Use this procedure to mount the FlexPendant holder onto a flat surface, like the top of the controller.

	Action	Note/illustration
1	Clean the surface and make sure it is dry.	
2	Remove the protective liner from the tape, located underneath the holder.	
3	Press the holder onto the desired place.	

Continues on next page

2 Installation and commissioning

2.4.4 Mounting the FlexPendant holder

Continued

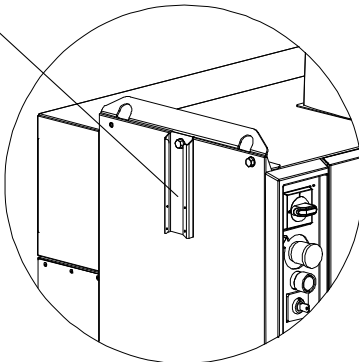
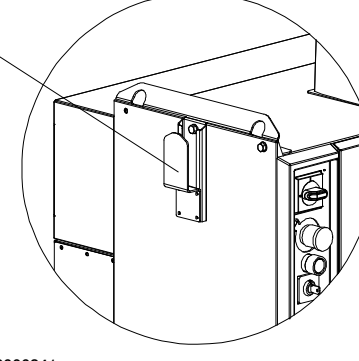
	Action	Note/illustration
4	Mount the cable bracket holder, for example, on the side of the cabinet using one of the existing M8 screws.	<p>A</p>  <p>xx0700000240</p> <ul style="list-style-type: none"> • A: Cable bracket holder
5	Mount the cable bracket on the cable bracket holder using enclosed Fastite screws (4 pcs).	<p>A</p>  <p>xx0700000241</p> <ul style="list-style-type: none"> • A: Cable bracket

Hang the FlexPendant holder with the bracket

Use this procedure to hang the FlexPendant holder on any place that can hold the bracket, like the door of the controller.

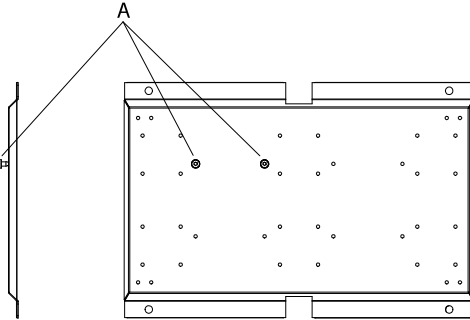
	Action	Note/Illustration
1	Secure the Fastite screws to the mounting plate.	<p>A</p>  <p>xx0800000048</p> <ul style="list-style-type: none"> • A: Fastite screw (2 pcs)

Continues on next page

2 Installation and commissioning

2.4.4 Mounting the FlexPendant holder

Continued

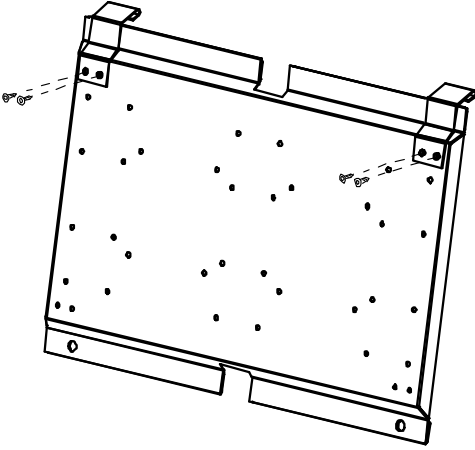
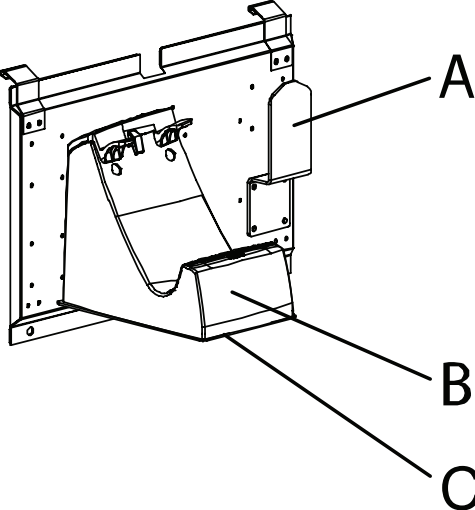
	Action	Note/Illustration
2	Secure the two hooks on the mounting plate with two Fastite screws for each hook.	 <p>xx110000052</p>
3	On the FlexPendant holder for the FlexPendant with emergency stop located at the outer edge, remove the metal sheet plate from underneath the holder.	
4	Place the FlexPendant holder and the cable bracket on the mounting plate and secure them with the enclosed Fastite screws (6 pcs).	 <p>xx1700001453</p> <ul style="list-style-type: none"> • A: Cable bracket • B: FlexPendant holder • C: FlexPendant metal sheet plate (Not available on all versions)
5	Make sure the surface where the holder will hang is clean and dry. This applies to surfaces both for the hooks and the back of the holder (mounting plate).	
6	Remove the protective liner from the tape on the mounting plate.	

Continues on next page

2 Installation and commissioning

2.4.4 Mounting the FlexPendant holder

Continued

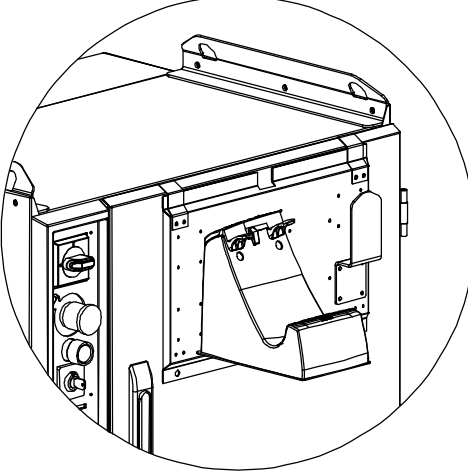
	Action	Note/Illustration
7	Hang the holder with the hooks in its location and then press the mounting plate against the surface.	 xx070000243

Mounting the bracket for the emergency stop on the FlexPendant holder

For the FlexPendant with emergency stop located at the connector, the holder includes a bracket to cover the emergency stop.

The FlexPendant holder is shipped without the bracket for the emergency stop assembled to the holder. They are separated as two parts.

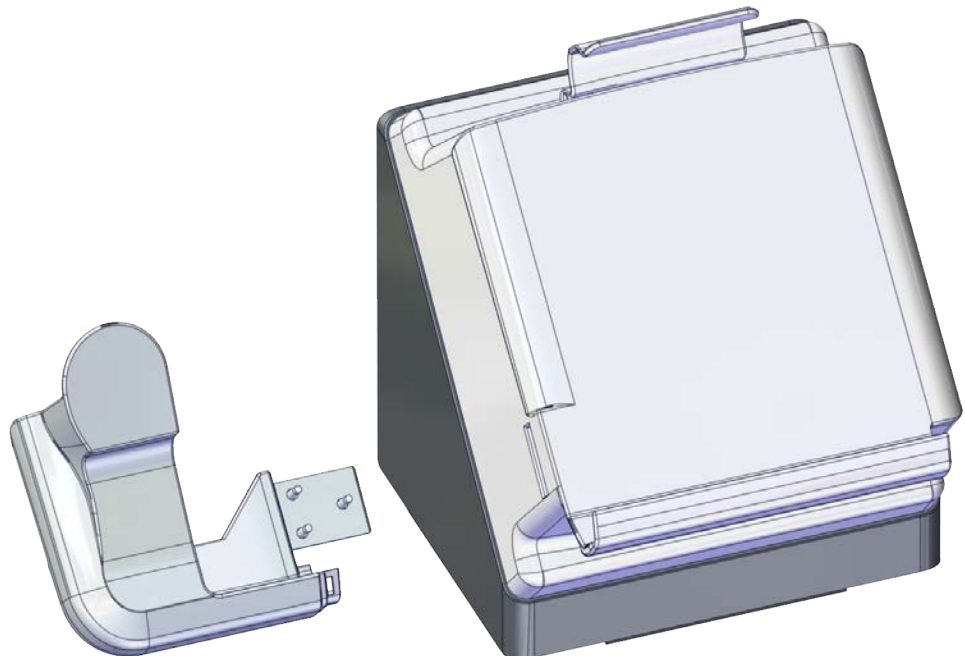

xx210000767



Continues on next page

2 Installation and commissioning

2.4.4 Mounting the FlexPendant holder

Continued

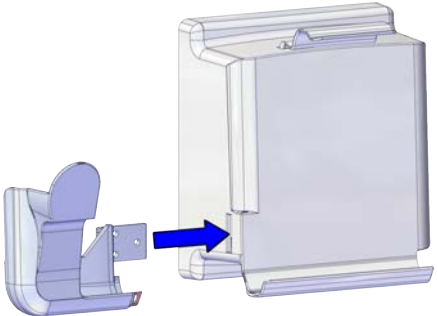
Use this procedure to mount the bracket for the emergency stop to the FlexPendant holder.

	Action	Note/illustration
1 2	Remove the four screws. Separate the rear part from the FlexPendant holder.	 <p>xx2000002356</p>
3	Insert the bracket into the FlexPendant holder.	 <p>xx2100000765</p>
4	Secure with the screws.	<p>Screws: BN33 Phillips pan head tapping screw ST2.9x13 (3 pcs) Tightening torque: 6 Nm-7.8 Nm</p>  <p>xx2100000766</p>

Continues on next page

2 Installation and commissioning

2.4.4 Mounting the FlexPendant holder

Continued

	Action	Note/illustration
5	Refit the rear part and secure with the screws.	<p>Screws: BN33 Phillips pan head tapping screw ST3.5x16 (4 pcs) Tightening torque: 9.4 Nm-12.2 Nm</p>  <p>xx2000002356</p>

2 Installation and commissioning

2.5.1 Connectors on the controller

2.5 Connections

2.5.1 Connectors on the controller

General

The following section describes the connectors on the front panel of the IRC5 controller.



CAUTION

Always inspect the connector for dirt or damage before connecting it to the controller. Clean or replace any damaged parts.



Note

It is important that the earth connection point (B) is connected to a ground plane, in order to avoid disturbance.

Connectors

The following details the connection interface on the IRC5 controller. See also the circuit diagram, *Circuit diagram - IRC5*.

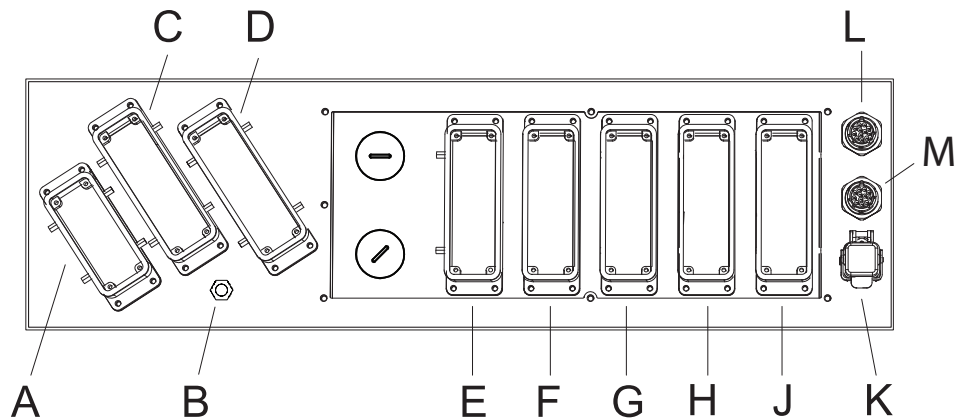

xx0500001852

	Description	Reference on the circuit diagram
A	Mains connection	XP.0
B	Earth connection point	
C	Robot power connection	XS.1
D	Additional axes power connection	XS.7
E	Customer power/signals external connection	XS.13/XS.5
F	Customer options	XS.10
G	Customer options	XS.11
H	Customer options	XS.12
J	Customer safety signals	X3

Continues on next page

2 Installation and commissioning

2.5.1 Connectors on the controller

Continued

	Description	Reference on the circuit diagram
K	Network connection	XS.28
L	Additional axes SMB connection	XS.41
M	Robot SMB connection	XS.2

2 Installation and commissioning

2.5.2 Connecting cables to the controller

2.5.2 Connecting cables to the controller

General

A good and proper electrical installation of the robot system is necessary to ensure the best performance and prolong the lifetime of the whole robot system.

This section includes important information on how to connect cables and signals to the controller.

Signal classes

Different rules apply to the different classes when selecting and laying cables. Signals from different classes must not be mixed.

Signal class	Description
Power signals Class 4 (noisy)	Supplies external motors and brakes. Applies to the cables associated with the power inputs and outputs of variable speed drives. Cables carrying strongly interfering signals such as motor cables, DC-link load sharing, unsuppressed inductive loads, DC motors, welding equipment, etc.
Control signals Class 3 (slightly noisy)	Digital operating and data signals (digital I/O, protective stop, etc.). Applies to cables carrying slightly interfering signals: AC power supply (<1 kV), DC power (24 V), power to equipment with RFI/EMI filters, control circuits with resistive or suppressed inductive loads (such as contactors and solenoids), direct-on-line induction motors, etc.
Measurement signals Class 2 (slightly sensitive)	Analog measurement and control signals (resolver and analog I/O). This class covers ordinary analogue signals such as analogue signals (4-20 mA, 0-10V, or signals below 1 MHz), low-speed digital signals (RS232, RS485), digital (on/off) signals, limit switches, encoders, etc.
Data communication signals Class 1 (sensitive)	Gateway (fieldbus) connection, computer link. Applies to cables carrying very sensitive signals. Signals with a full-scale range less than 1 V or 1 mA, and/or a source impedance >1 kOhm, and/or a signal frequency >1 Mhz. For example high-speed digital communication (Ethernet), thermocouples, thermistors, strain gauges and flowmeters.

Selecting cables

All cables laid in the control cabinet must be capable of withstanding 70 °C. In addition, the following rules apply to the cables of certain signal classes:

Signal class	Cable type
Power signals	Shielded cable with an area of at least 0.75 mm ² or AWG 18.
Control signals	Shielded cable.
Measurement signals	Shielded cable with twisted pair conductors.
Data communication signals	Shielded cable with twisted pair conductors. A specific cable should be used for field bus connections and Ethernet, according to the standard specification of the respective bus.

Continues on next page



Note

Any local standards and regulations concerning insulation and area must always be complied with.

AC current in CP/CS

For specific applications where the correct cable dimensioning can depend on the relationship between the period of the duty cycle and the thermal time constant of the cable (for example, starting against high-inertia load, intermittent duty), the cable manufacturer can provide information.

Country specific norms have to be included.

The wire is not dimensioned to take care of starting motors or transformers.

The following table shows how much AC current can be supplied with a specific temperature, and the wire size.

Wire size (mm ² //AWG)	AC current			
	40°C//104F	45°C//113F	50°C//122F	52°C//125.6F
Single wire 0.2//24	4.5	4.1	3.7	3.2
Multi wire 2 pair 0.2//24	3.6	3.3	3.0	2.6
Multi wire 4 pair 0.2//24	2.9	2.7	2.4	2.1
Multi wire 6 pair 0.2//24	2.6	2.3	2.1	1.8
Multi wire 9 pair 0.2//24	2.3	2.0	1.8	1.6
Single wire 0.5//20	7.9	7.2	6.5	5.6
Multi wire 2 pair 0.5//20	6.3	5.8	5.2	4.5
Multi wire 4 pair 0.5//20	5.1	4.7	4.2	3.6
Multi wire 6 pair 0.5//20	4.5	4.1	3.7	3.2
Multi wire 9 pair 0.5//20	4.0	3.6	3.2	2.8
Single wire 0.75//18	9.5	8.6	7.8	6.7
Multi wire 2 pair 0.75//18	7.6	6.9	6.2	5.4
Multi wire 4 pair 0.75//18	6.2	5.6	5.1	4.4
Multi wire 6 pair 0.75//18	5.4	4.9	4.4	3.8
Multi wire 9 pair 0.75//18	4.8	4.3	3.9	3.4
Single wire 1.0//17	11.0	10.0	9.0	7.8
Multi wire 2 pair 1.0//17	8.8	8.0	7.2	6.2
Multi wire 4 pair 1.0//17	7.2	6.5	5.9	5.1
Multi wire 6 pair 1.0//17	6.3	5.7	5.1	4.5
Multi wire 9 pair 1.0//17	5.5	5.0	4.5	3.9
0.75//18 three phase	8.6	7.8	7.1	5.6
1.0//17 three phase	10.3	9.4	8.4	6.7

Continues on next page

2 Installation and commissioning

2.5.2 Connecting cables to the controller

Continued

Route the cables

Routing of cables shall be done in a professional way.

- Cables of different classes, such as signal cables and power cables, must not be routed together as the power cables may introduce noise in the signal cables. The greater the separation distance, the lesser the risk for interference between the cables.
- Robot controller mains supply input cable and robot power cable should be separated even though they belong to the same class.
- If crossing cables from different classes, cables should cross at an angle close to 90 degrees.
- All external cables that are to be connected inside the controller must be shielded in the chassis before entering the cabinet.

Separation distances can be reduced if e.g. dividers are used between cables classes. Manufacturers of cable duct systems can provide information on how reduced separation distances can be achieved using their specific products.

All signals that are sensitive to interference should be routed and strapped along the right side of the controller cabinet according to the image.

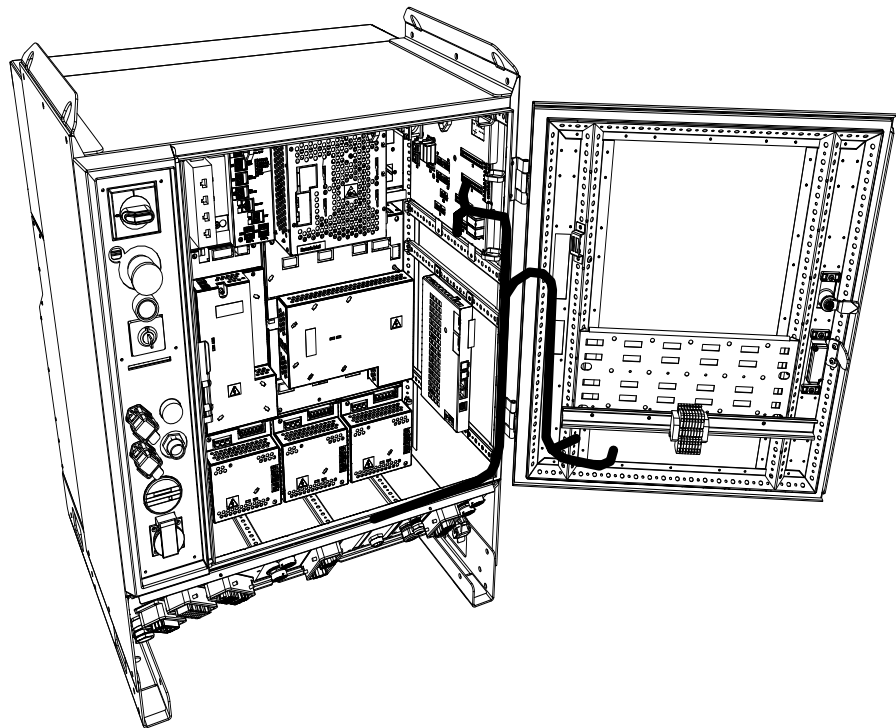

xx130000853

Continues on next page

Signal class	Cable type
Power signals	<ul style="list-style-type: none">• These signals generate a lot of interference and must be laid separate from control, measurement, and communication signals.• The shielding must be connected to a paint-free part of the panel chassis of the cabinet at both ends of the cable. Any unshielded cable must be as short as possible.• The manipulator power cables are routed on the floor and along the left side of the controller cabinet.• Cables should not be wound up like coils. This could cause an magnetic field disturbing the signals. There will also be a risk of overheating depending on the load.
Control signals	<ul style="list-style-type: none">• These signals are very sensitive to interference. To protect these signals they should not be laid along with the power signals.• In the cable, each signal must be twisted with a neutral wire.• The shielding must be connected directly to the chassis at both ends of the cable.
Measurement signals	
Data communication signals	

Shielding cables

When peripheral devices are connected to the robot system, a shielded cable is necessary to reduce coupling of the inner cable conductors to the environment they pass through.

Shielding cable requirements

- The best method for shielding is to ground the shield at both ends of the cable, provided the ends grounding are at the same potential.
- If the grounding points have different electric potentials - grounding both ends will create a ground loop allowing unwanted current to flow in the shield. In such cases one end grounding may be used. The grounding point should then be at the robot controller side.
- Cables carrying analog low-level signals is another exception where the shield should be grounded at only one end.
- Most data network and field bus types have defined grounding topologies. If such grounding schemes exist, they should be followed.
- In complex interference environments, two-layer shielding may be required. The inner shield should be grounded at the controller side only end and the outer shield should be grounded at both ends. The optimum shielding is a combination of foil and braid screens.
- The best connection is one in which the shielding is extended up to and makes a solid 360° connection (shown below) with the ground plane or chassis.

Continues on next page

2 Installation and commissioning

2.5.2 Connecting cables to the controller

Continued

Shielding example

The below example shows the shielding of a d-type connector:

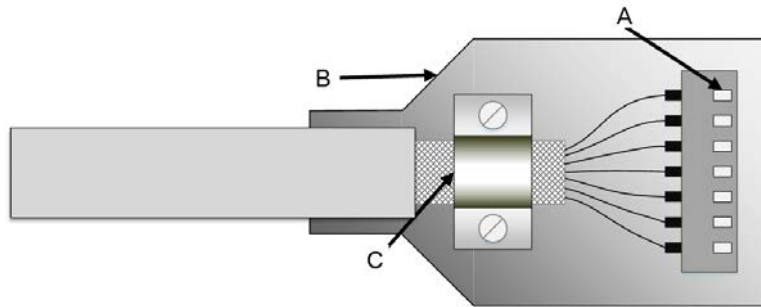

xx1700001320

- A A dimpled connector body makes multiple bonds to the mating connector body all around its periphery, 360° bonding.
- B Metal, or metallized, back shell makes 360° bond to the connector body.
- C The cable shield is exposed and 360° clamped to the back shell. A tight fit is a must.

Many other 360° bonding methods and types of 360° shielded connectors are also acceptable.

Shield pigtail termination

Shield pigtail termination, as shown below, shall be avoided. If a pigtail connection cannot be avoided, make it as short as possible.

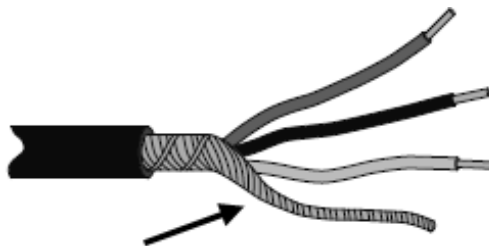

xx1700001321

Ground and screen connections

The task of the grounding system is twofold - protective and functional. The primary task is to serve as protective earth (PE) for personal and equipment safety. The secondary task is to serve as a return path for common mode current.

For further information refer to EN 60204-1 and UL 1740.

Grounding requirements

The controller cabinet ground must come from the mains power supply PE.

- The cross-sectional area of each grounding (PE) conductor must be not less than 10 mm² copper (AWG7) in the IRC5 controller and in the manipulator.
- The grounding cable color shall be green-yellow.
- The ground for the controller cabinet, robot manipulator and peripheral devices must be the same, preferably an equipotential ground grid (mesh).

Continues on next page

- Ground connection points must have stable inter-metallic bonding, like screw fixation. Paint, dirt, rust, and other insulating material must be removed from the contacting surfaces.

For requirements on the marking of the supply ground connection inside the control cabinet refer to UL 508C. For further details on how grounding systems should be designed refer to IEC 61000-5-2. For details of cross-sectional area of PE refer to IEC 60204-1.

Grounding installation

For information on how to install the ground for the IRC5 controller cabinet, see [Connecting power supply to the controller on page 72](#).

For information on how to connect protective earth for the manipulator, see the corresponding product manual.

Examples

The following figure shows 2 examples on how protective earth and the signal cable screens can be connected:

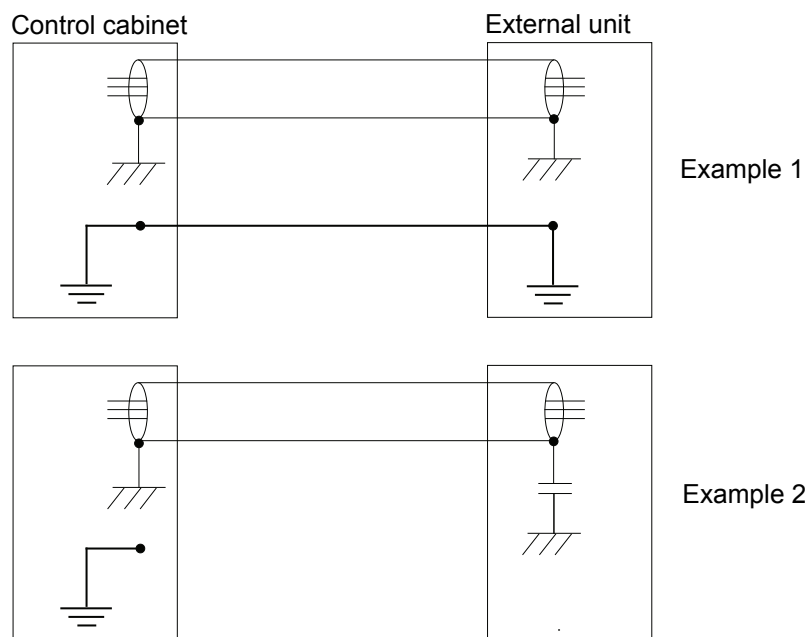

xx120000960

Example 1:

- Where a good earth connection is available on all units, the best shielding is obtained by grounding all screens at both ends on all units.

Example 2:

- If the cable is terminated where a good earth connection is not available a noise suppression capacitor can be used. The screens of the 2 cables must be connected as shown in the figure, but not connected to the chassis of the unit.

Continues on next page

2 Installation and commissioning

2.5.2 Connecting cables to the controller

Continued

Interference elimination

Internal relay coils and other units that can generate interference inside the control cabinet are neutralized. External relay coils, solenoids and other units must be clamped in a similar way. The illustration below shows how this can be done.

Note that the turn-off time for DC relays increases after neutralization, especially if a diode is connected across the coil. Varistors give shorter turn-off times. Neutralizing the coils lengthens the life of the switches that control them.

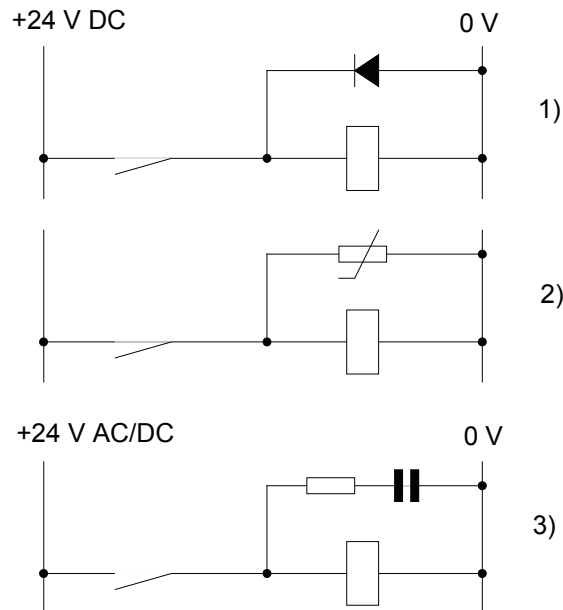

xx120000961

- 1 The diode should be dimensioned for the same current as the relay coil, and a voltage of twice the supply voltage.
- 2 The varistor should be dimensioned for the same energy as the relay coil, and a voltage of twice the supply voltage.
- 3 When AC voltage is used, the components needs to be dimensioned for >500 V max voltage and 125 V nominal voltage.

The resistor should be 100 Ω , and the capacitor should be 1W 0.1 - 1 μF (typically 0.47 μF).

2.5.3 Power supply system requirements

Definition of the power supply system

IEC 60364 defines three different types of mains grounding using the two-letter codes. These are TN, TT, and IT.

First letter	Type of ground connection
T	Direct connection of one point to ground.
I	Not connected to ground or connected to ground via a high impedance.

Second letter	Connection between ground and the device being supplied
T	Direct connection of one point to ground.
N	Direct connection to neutral at the origin of installation, which is connected to the ground

In the following section the transformer configuration refers to the transformer secondary side. Configuration of the transformer primary side is not discussed in this context.

Recommended power supply systems

The following systems are recommended by ABB:

TN-S system	TN-C system
PE and N are separate conductors that are connected together only near the transformer.	A combined PEN conductor is used as both a PE and an N conductor.
<p>xx1700001310</p>	<p>xx1700001311</p>

Not recommended power supply systems

The following systems are not recommended by ABB:

TT system (separate ground rods)	Resistance grounded secondary system
If this kind of system must be used, the grounding path resistance between ground 1 and 2 shall not exceed 0.1 Ohm, for more information refer to UL1740.	If this kind of system must be used, the voltage variations between any line and PE should not exceed $\pm 10\%$ of the nominal line voltage, for more information refer to EN 50160.

Continues on next page

2 Installation and commissioning

2.5.3 Power supply system requirements

Continued

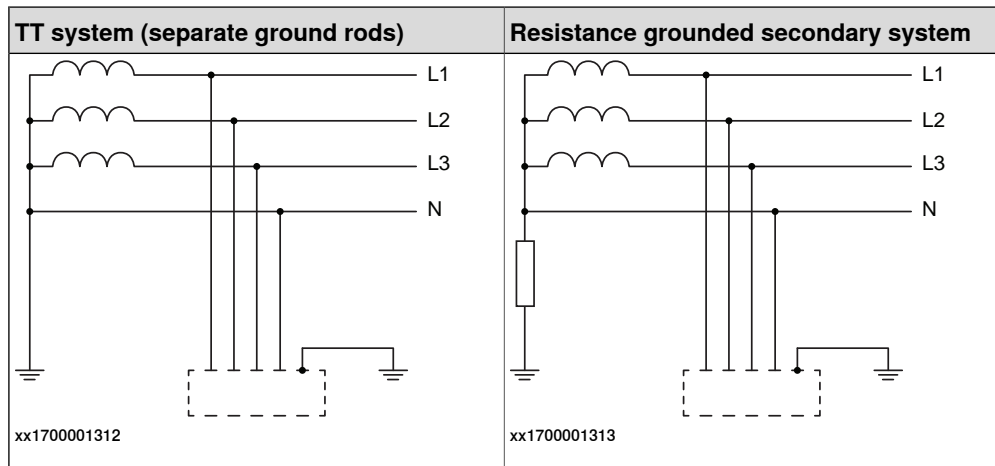

Not allowed power supply systems

The following systems are not allowed by ABB:

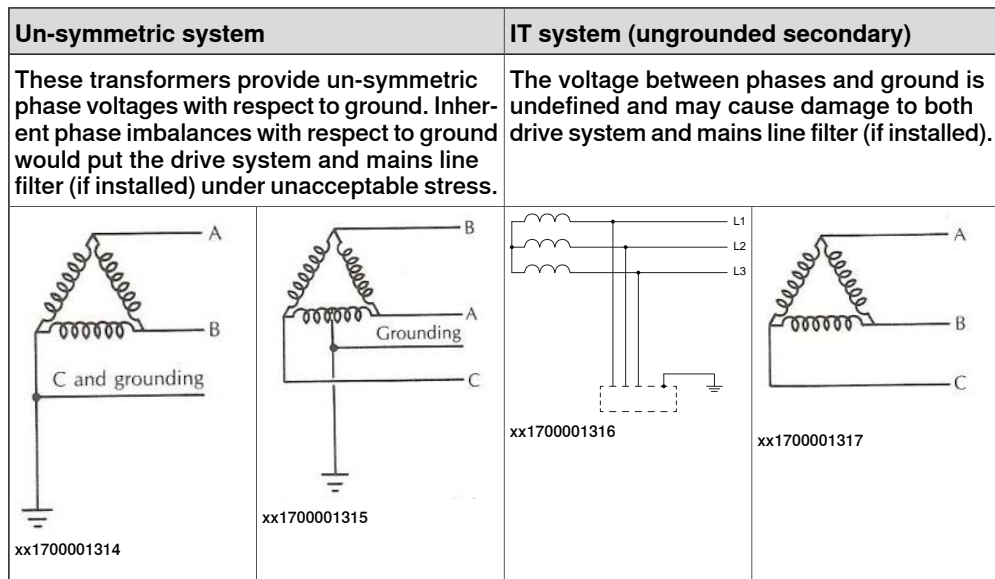

Isolation transformer

A three-phase isolation transformer between the mains supply and the control cabinet is required for any of the below conditions:

- Not allowed power supply system used, as mentioned in [Not allowed power supply systems on page 70](#).
- When the mains supply is shared with a pressing machine, frequency converter, or other large industry equipment that may cause the power supply characteristics out of standard limits. To some extent, isolation transformers will filter out harmonics, spikes and surges.

For further information refer to regional power supply standards.

Continues on next page

Allowed isolation transformer types

The following isolation transformer types are allowed by ABB:

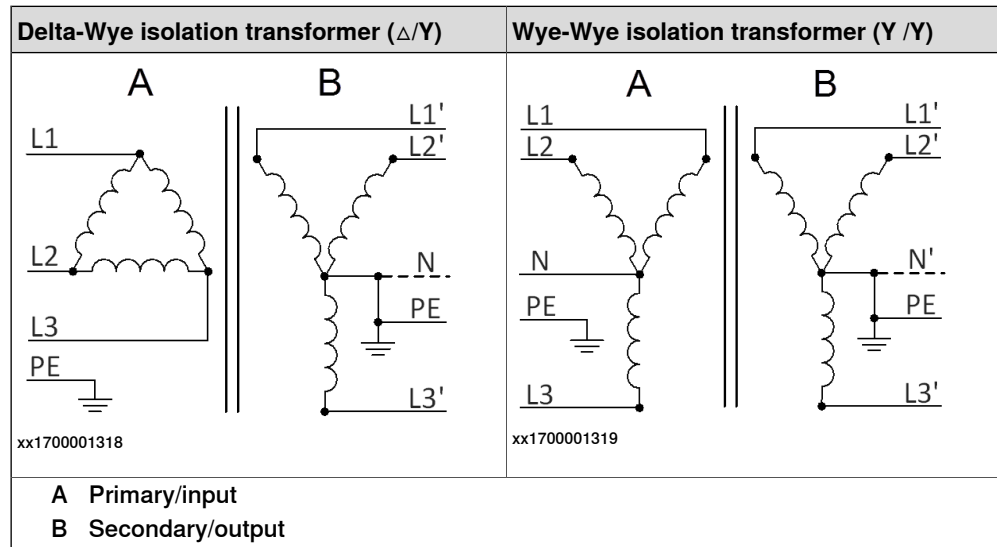

Mains line filter

The IRC5 controller option *129-1 Prepared for CE labelling* consists of a mains line filter (3HAC024322-001) to prevent emissions to the incoming power, ensuring compliance with EN/IEC 61000-6-4.

A mains line filter in each robot cabinet is required for any of the below conditions:

- Robot system CE-labelling is required.
- Robot system will be installed in an EU country.

Other types of external filters may be used, provided they are approved by regional standards. For further information refer to regional power supply standards.

2 Installation and commissioning

2.5.4 Connecting power supply to the controller

2.5.4 Connecting power supply to the controller

Location of power supply connection

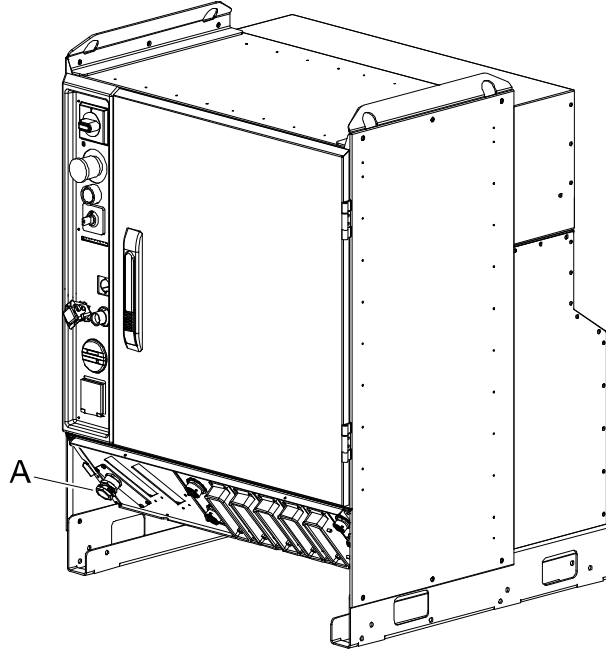

xx0500001869

A	Cable gland
---	-------------

Rated voltage and current

To find the rated voltage, the full load current, and short circuit current rating of the controller, see the name plate (label) on the side of the cabinet.

The illustration shows an example of the position of the label.

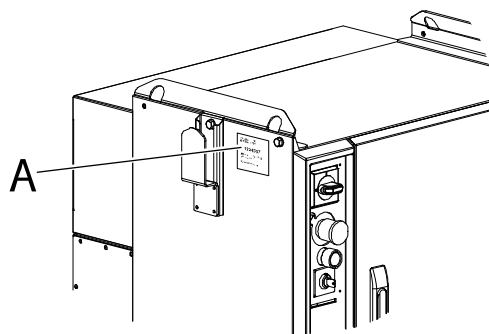

xx0900000273

A	Controller name plate
---	-----------------------

Short Circuit Current Rating (SCCR)	Ampere
UL/CSA	10 kA
EU(IEC)	6.5 kA

Continues on next page



Note

UL/CSA: The line fuse is considered to be part of the main feeder circuit according to UL508A SB4.3.3. The controller rating is limited to 10 kA with the fuse.



Note

The use of three-phase power with delta connection (as sometimes used in North Americas and some Asian countries) voids warranty. If the facility has a substation with any type of delta connection, a grounded Y-configured transformer must be installed before the robot controller.

Line fusing

Recommended fuse or breaker characteristics:

- UL/CSA: J, T, RK1^I slow blowing fuse with max 5 kA peak let-through current.
- EU/IEC: Slow-blowing fuse or circuit breaker with trip characteristic K. Max cut-off current max 6.5 kA, max rated conditional short circuit current 50 kA.

^I RK1 should only be used with max 25A line fusing.

Robot	Voltage	Recommended line fusing
IRB 120, 1200, 140, 1600, 2400, 2600, 260, 360, 390, 4400	at 400-660 V	3x16 A
IRB 120, 1200, 140, 1600, 2400, 2600, 260, 360, 390, 4400	at 200-220 V	3x16 A
IRB 4600, 660, 460, 760, 6650S, 6700, 7600, 8700	at 400-600 V	3x25 A
IRB 660, 66XX, 6700, 760, 7600, 8700	at 200-220 V	3x35 A
IRB 4600, 660, 460, 760, 66XX, 6700, 7600, 8700	at 200-220 V	3x35 A



Note

The label on the robot controller shows the rated voltage, the full load current, and the rated short-circuit current, intended for the electrical installation of the product. The actual power consumption in an application might be lower as it depends on the actual application.

Transformer

For information about included servo transformer, see *Product specification - Controller IRC5*.

Note that not all voltage levels are available for all transformers, but the voltage tolerance is -15%...+10%.



Note

If another voltage is used than the one specified on the controller name plate, this should be replaced so the name plate has the correct information.

Continues on next page

2 Installation and commissioning

2.5.4 Connecting power supply to the controller

Continued

Prerequisites

Equipment	Note
Power supply cable (3-phase)	
External earth fault protection (residual current circuit breaker, Class B for frequency converters, 300mA)	For control cables up to 7m, a 30mA earth fault protection can be used if it is Hager CDH440R, CDH440D or equal residual current circuit breaker.
Standard toolkit	See Standard toolkit, IRC5 on page 323 .
Other tools and procedures may be required. See references to these procedures in the step-by-step instructions below.	These procedures include references to the tools required.
Circuit diagram	See Circuit diagrams on page 349 .

Connection through a cable gland

The following procedures detail how to connect the mains power to the controller through a cable gland.

	Action	Note/illustration
1	Connect power supply from an external earth fault protection.	Prerequisites on page 74

Continues on next page

2 Installation and commissioning

2.5.4 Connecting power supply to the controller

Continued

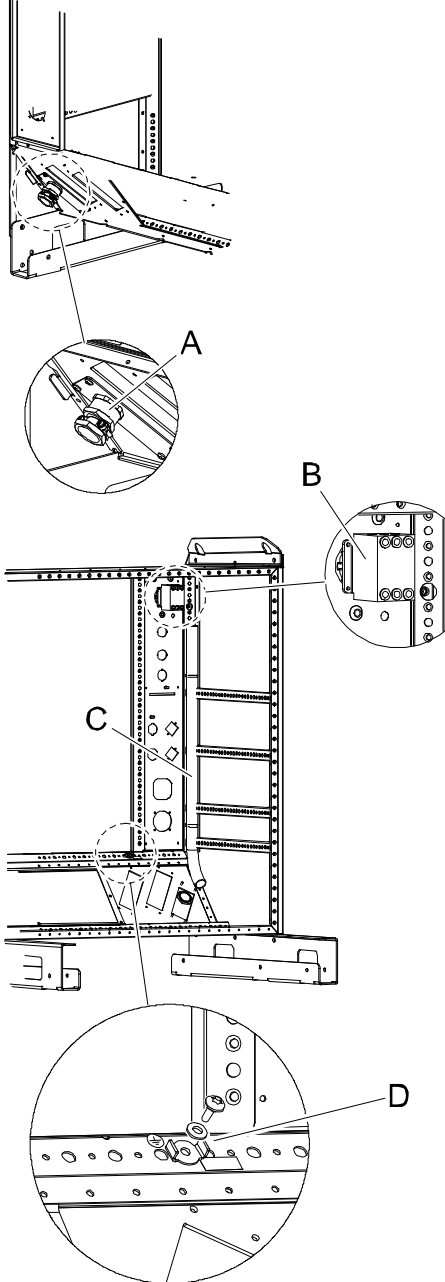
	Action	Note/illustration
2	Fit the cable trough the cable gland and tighten.	 <p data-bbox="973 1601 1085 1624">xx0500001870</p> <p data-bbox="973 1635 1037 1657">Parts:</p> <ul data-bbox="1005 1668 1244 1792" style="list-style-type: none"> • A: cable gland • B: rotary switch • C: cable pipe • D: grounding point
3	Strip the insulation on the power supply cable long enough to reach the rotary switch.	
4	Connect the ground cable at the <i>grounding point</i> .	See illustration in step 2. Tightening torque, 4.5 Nm.

Continues on next page

2 Installation and commissioning

2.5.4 Connecting power supply to the controller

Continued

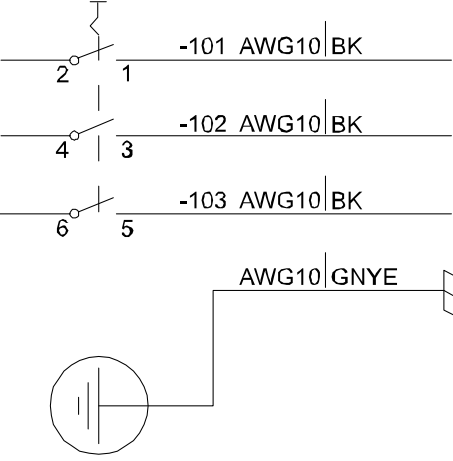
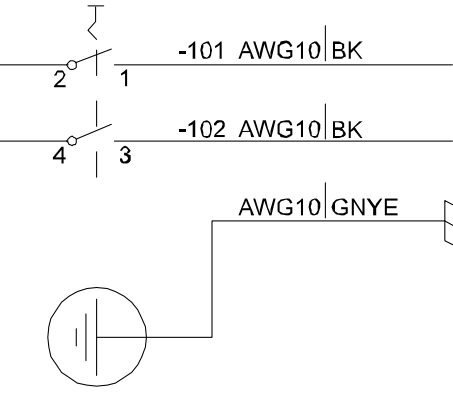
	Action	Note/illustration
5	Route the phase wires through the pipe up to the rotary switch.	See illustration in step 2.
6	Connect the wires as shown in the illustration.	<p>For three phase: Rotary Switch</p>  <p>xx0500001882</p> <p>For single phase: Rotary Switch</p>  <p>xx1100000019</p> <p>For single phase, pin 5 is plugged.</p>

Connection through a connector

The following procedures detail how to connect the mains power to the controller through a connector.



CAUTION

Always inspect the connector for dirt or damage before connecting it to the controller. Clean or replace any damaged parts.

Continues on next page

2 Installation and commissioning

2.5.4 Connecting power supply to the controller

Continued

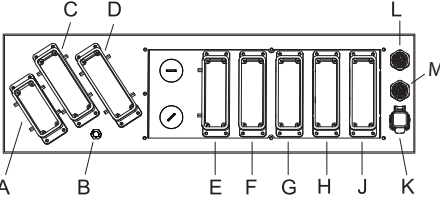
	Action	Note/illustration
1	Connect the power cable from the shop supply to connector XP0 on the front panel on the controller.	 <p data-bbox="986 517 1093 539">xx0500001852</p> <p data-bbox="986 551 1054 573">Parts:</p> <ul data-bbox="1018 577 1406 607" style="list-style-type: none"><li data-bbox="1018 577 1406 607">• A: XP0 Mains power connector

2 Installation and commissioning

2.5.5 Connecting the manipulator to the controller

2.5.5 Connecting the manipulator to the controller

General

Connect the manipulator and the controller to each other after installing them. The lists below specify which cables to be used in each application.

All connectors on the controller are shown in section [Connectors on the controller on page 60](#).

Main cable categories

All cables between the manipulator and the controller are divided into the following categories:

Cable category	Description
Manipulator cables	Handles power supply to and control of the manipulator's motors as well as feedback from the serial measurement board.
Position switch cables (option)	Handles supply to and feedback from any position switches.
Customer cables (option)	Handles communication with equipment fitted on the manipulator by the customer.
Additional axes cables (option)	Handles power supply to and control of the external axes motors as well as feedback from the servo system.

These categories above are divided into sub-categories which are specified in section [Manipulator cables on page 336](#).



Tip

In case duplicate CP/CS harnesses are included on delivery, one can be saved as a spare part.

2.5.6 Connecting safety signals



CAUTION

For connection of safety signals, see the circuit diagram for details.



CAUTION

All safety signals are two-channel.

External customer connection

If the cabinet is equipped with the option external customer connection, connect the connector as shown in the following illustration.



CAUTION

Always inspect the connector for dirt or damage before connecting it to the controller. Clean or replace any damaged parts.

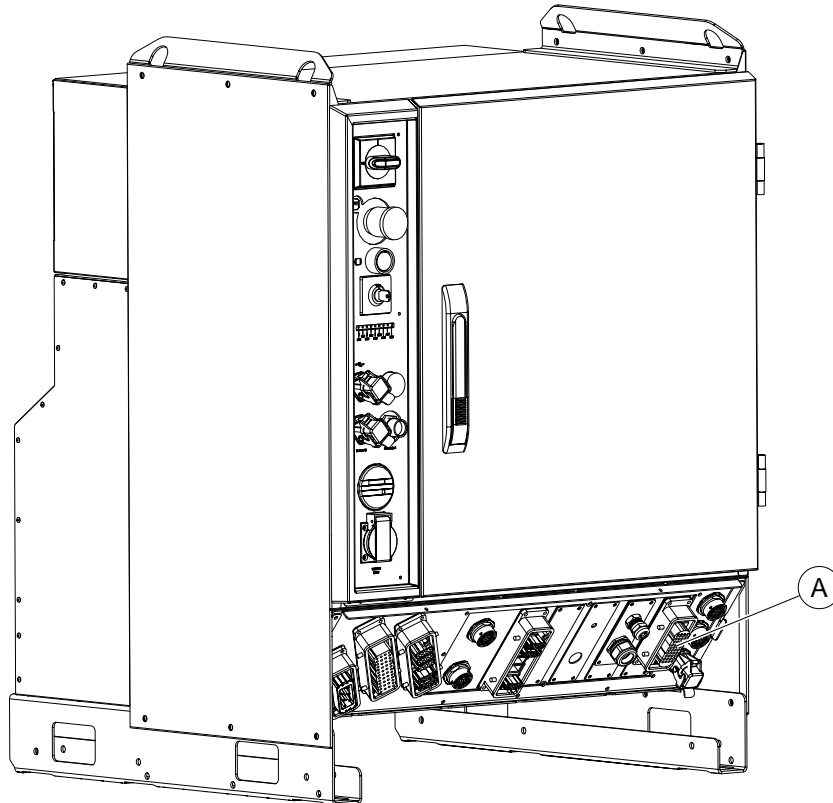

xx130000601

A	External customer connection of safety signals.
---	---

Continues on next page

2 Installation and commissioning

2.5.6 Connecting safety signals

Continued

Internal customer connection

If the cabinet is not equipped with the option external customer connection, the signal cables must go through a cable gland and be connected to the panel board inside the cabinet.

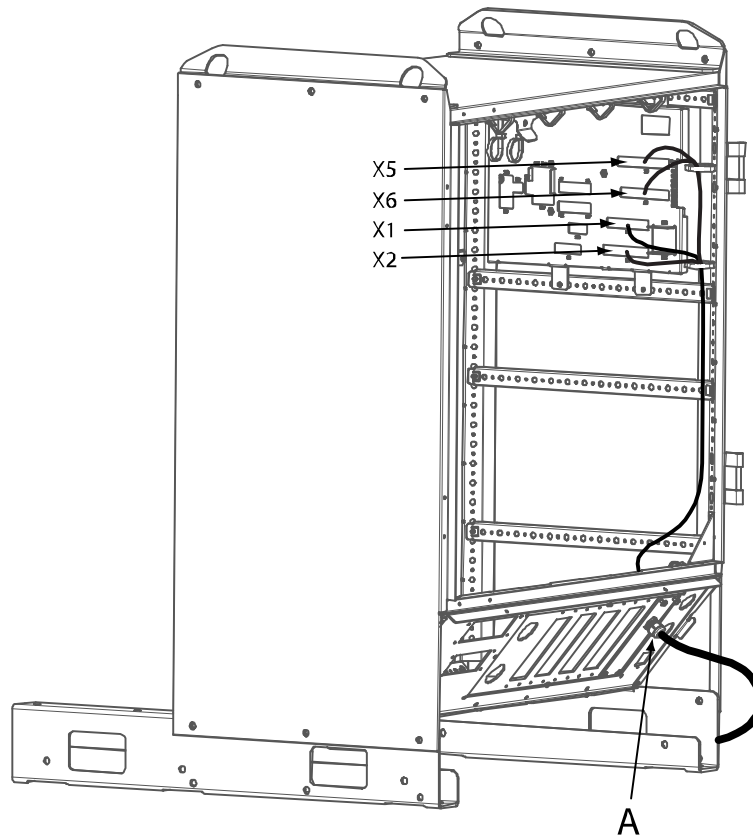

xx100000141

A	Cable gland
---	-------------



Note

The signal cable should be shielded and the shielding connected to the cable gland, or a ferrite ring should be used around the cable inside the cabinet close to the cable gland. The same goes for all customer I/O signals.

Related information

[Connection of external safety relay on page 81](#)

[Connection of the MOTORS ON/MOTORS OFF circuit on page 83](#)

2.5.7 Connection of external safety relay

Description

The motor contactors K42 and K43 in the controller can operate with external equipment if external relays are used.

Connection example

The following figure shows an example of how to connect an external safety relay.

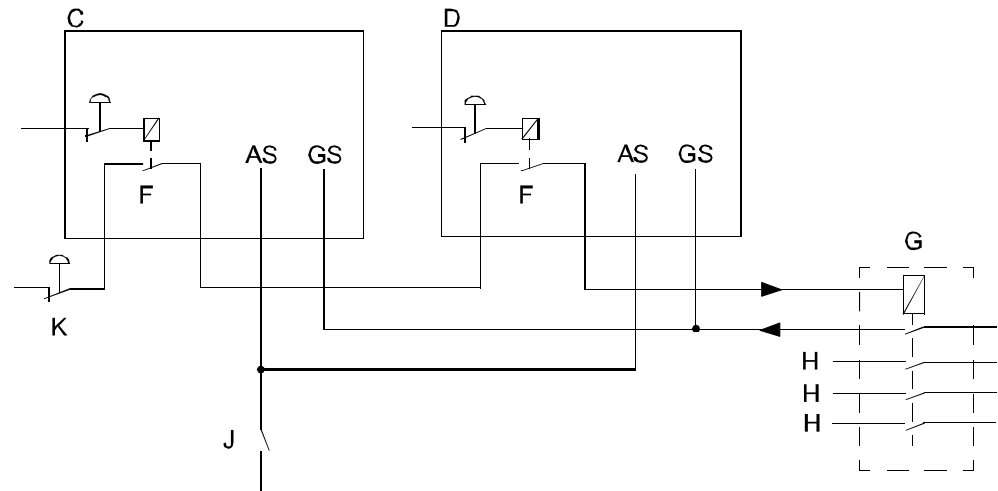

xx0100000246

C	Robot 1
D	Robot 2
F	ES (emergency stop) relay
G	External Safety relay
H	To other equipment
J	Safety gate
K	Cell ES (emergency stop)

2 Installation and commissioning

2.5.8 Closing the Automatic Stop circuit

2.5.8 Closing the Automatic Stop circuit

Closing the Automatic Stop circuit

The controller is shipped with a default configuration so that the automatic stop circuit is open and the general/superior stop circuit is bypassed (short-circuited). The system can only work in manual mode.

To enable the controller without any additional/external safety equipment, connect the safety circuit. To bypass Automatic stop circuit, 3-pole jumpers are enclosed in bag 3HAC078549-001 with corresponding instruction 3HAC078652-001. See the circuit diagram, *3HAC024480-011*.

2.5.9 Connection of the MOTORS ON/MOTORS OFF circuit

Outline diagram

The MOTORS ON/MOTORS OFF circuit is made up of two identical chains of switches.

The diagram shows one of the chains with the available customer connections, AS, GS, SS, and ES.

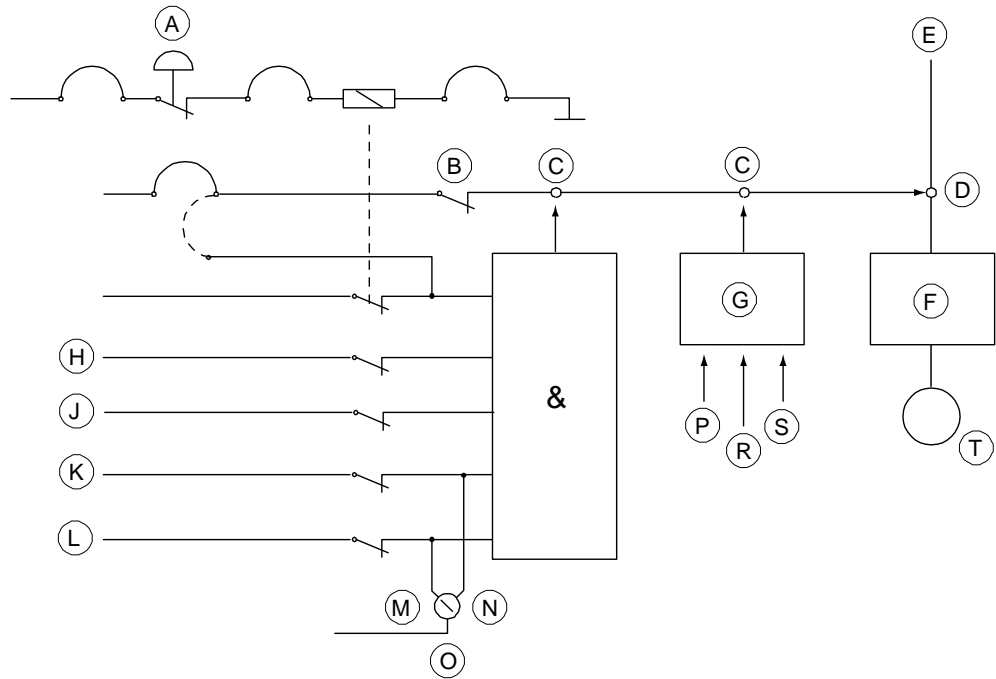

xx010000174

A	ES (emergency stop)
B	LS (Limit switch)
C	Solid state switches
D	Contactors
E	Mains
F	Drive unit
G	Second chain interlock
H	GS (general mode safeguarded space stop)
J	SS (superior stop, same function as GS)
K	AS (Automatic mode safeguarded space stop)
L	ED (FlexPendant three-position enabling device)
M	Manual mode
N	Automatic mode
O	Operating mode selector
P	RUN

Continues on next page

2 Installation and commissioning

2.5.9 Connection of the MOTORS ON/MOTORS OFF circuit

Continued

R	EN1
S	EN2
T	Motor



Note

Make sure the polarity is correct and that the voltage is not more than 24 V.

Function of the MOTORS ON/MOTORS OFF circuit

The circuit monitors all safety related equipment and switches. If any of the switches is opened, the MOTORS ON/MOTORS OFF circuit switches the power to the motors off.

As long as the two channels of AS, GS, SS, and ES are not in identical state, the robot will remain in protective stop and MOTORS OFF mode.

Connection of safety chains

The diagram below shows the dual channel safety chain.

The supply from internal 24V and 0 V is displayed. For external supply of GS and AS check the circuit diagram.

Continues on next page

2 Installation and commissioning

2.5.9 Connection of the MOTORS ON/MOTORS OFF circuit

Continued

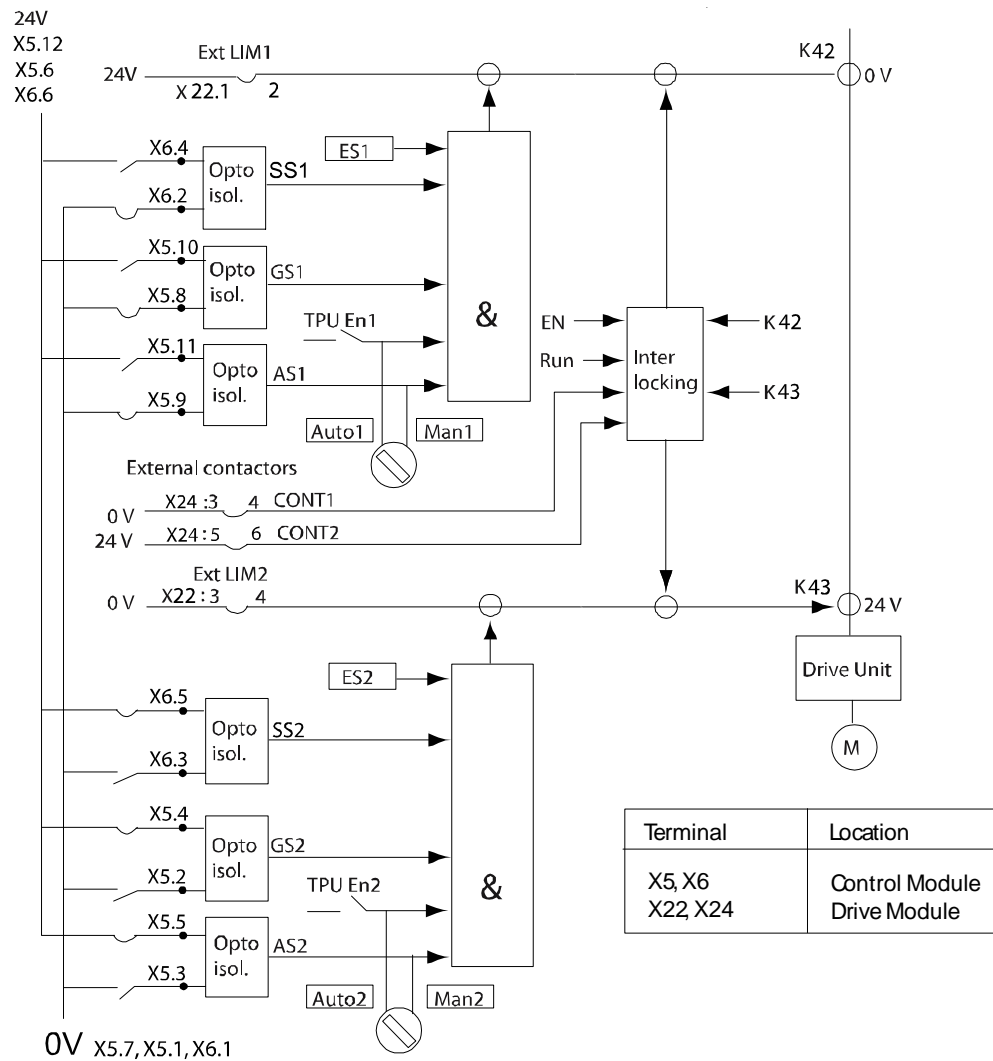

xx0100000166

Technical data per chain	
Limit switch	Load: 300 mV Max. voltage drop: 1 V
External connectors	Load: 10 mA Max. voltage drop: 4 V
GS/AS/SS load at 24 V	25 mA
GS/AS/SS closed "1"	>18 V
GS/AS/SS open "0"	< 5 V
External supply of GS/AS/SS	Max. + 35 VDC Min. - 35 VDC
GS/AS/SS Filter time	2.0 ms ⁱ
Max. potential in relation to the cabinet earthing and other signal groups.	300 V

Continues on next page

2 Installation and commissioning

2.5.9 Connection of the MOTORS ON/MOTORS OFF circuit

Continued

Technical data per chain	
Signal class	Control signals

i When connecting for example a safety PLC to a safety stop, make sure that the safety check pulses not exceeds 2.0 ms, otherwise a safety relay must be connected in between. See the following illustration.

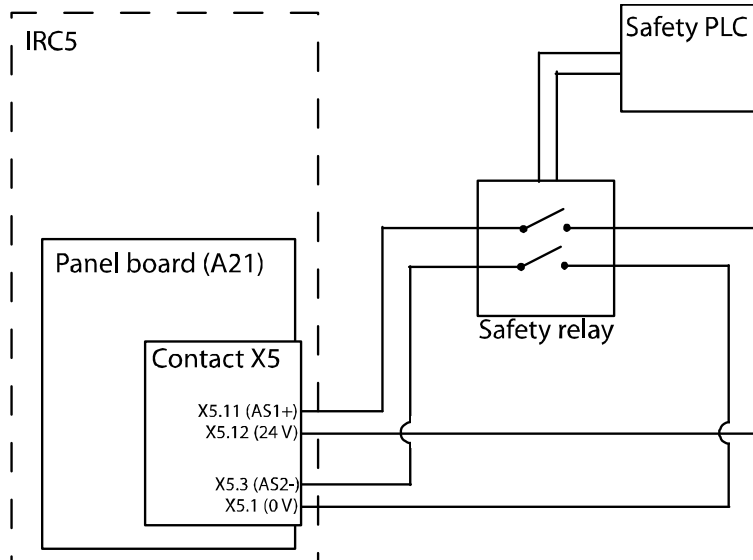

xx0800000130

Connection of ES1/ES2 on panel unit



Note

The diagram below shows the terminals for the emergency circuits for a controller without safety module (option 996-1). For a controller with a safety module, status signals for emergency stop can only be read from the safe fieldbus (see *Application manual - Functional safety and SafeMove2*).

The supply from internal 24V (X1:4/X2:8) and 0V (X1:8/X2:4) is displayed. For an ext. supply, X1:3 / X2:7 is connected to ext. 24V, and X1:7 / X2:3 is connected to ext. 0V.

Continues on next page

2 Installation and commissioning

2.5.9 Connection of the MOTORS ON/MOTORS OFF circuit

Continued

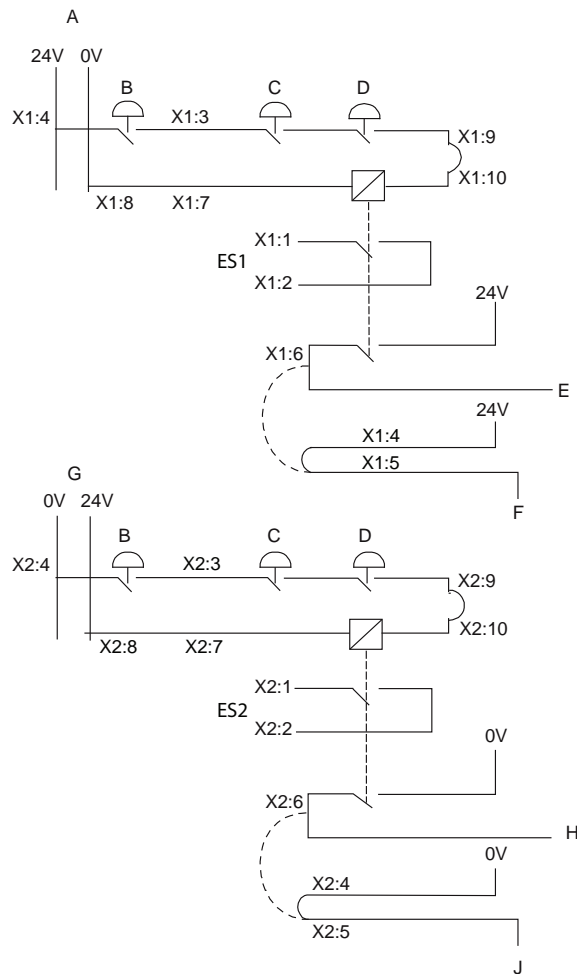

xx0100000191

A	Internal
B	Ext stop
C	FlexPendant
D	Cabinet
E	ES1 internal
F	Run chain 1 top
G	Internal
H	ES2 internal
J	Run chain 2 top
ES1	Emergency stop output 1
ES2	Emergency stop output 2

Technical data	
ES1 and ES2 max output voltage	120 VAC or 48 VDC

Continues on next page

2 Installation and commissioning

2.5.9 Connection of the MOTORS ON/MOTORS OFF circuit

Continued

Technical data	
ES1 and ES2 max output current	120 VAC: 4 A 48 VDC L/R: 50 mA 24 VDC L/R: 2 A 24 VDC R load: 8 A
External supply of ES relay	24 VDC \pm 10% between terminals X1:3, 7 and X2:7, 3 respectively. Note In case of interference, the external supply must be properly filtered.
Rated current per chain	40 mA
Max. potential in relation to the cabinet earthing and other signal groups.	300 V
Signal class	Control signals

Connection to operating mode selector

The illustration below shows the connection of terminals for customer use.

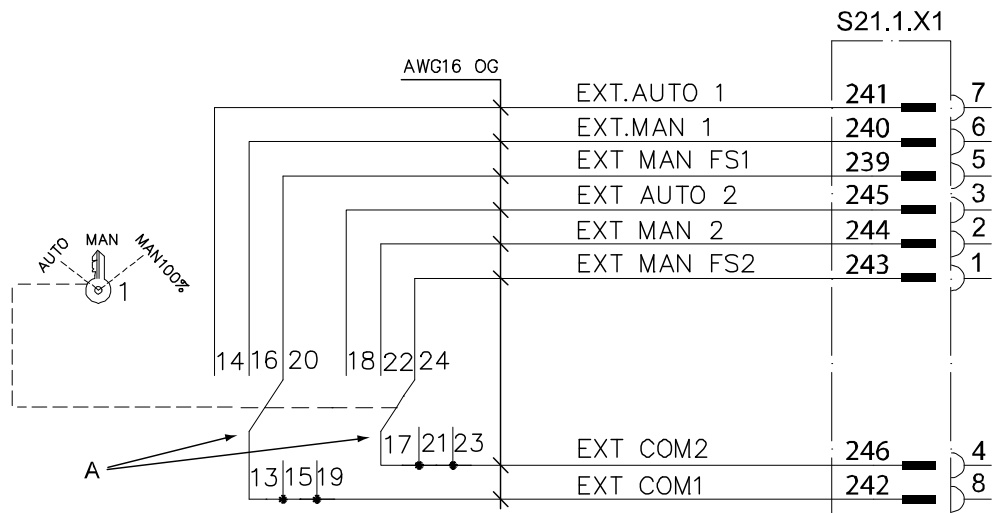

xx0500002092

Technical data	
Max. voltage	48 VDC
Max. current	4 A
Max. potential in relation to the cabinet earthing and other signal groups.	300 V
Signal class	Control signals

2.5.10 Connection to MOTORS ON/MOTORS OFF contactor

General

This section details connection to the MOTORS ON/MOTORS OFF contactor. To be used when the customer wants external equipment to follow the robot control.

Location

The MOTORS ON/MOTORS OFF contactor is located on the left hand side in the controller.

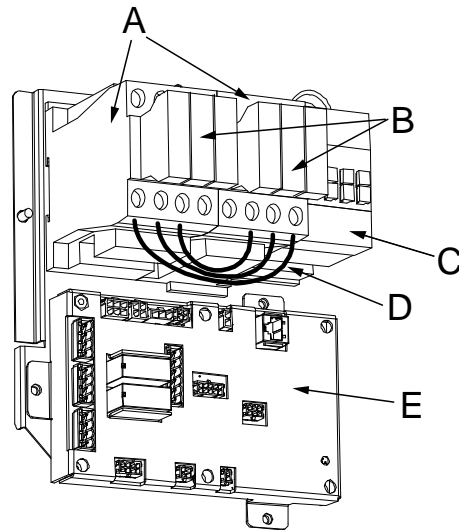

xx0400001058

A	MOTOR ON contactor K42 / K43
B	Contactor auxiliary block 33-34
C	Brake contactor
D	Jumper (3 pcs)
E	Contactor interface board

Required equipment

The table below details the required equipment.

Equipment	Note
Standard toolkit	
Circuit diagram	See Circuit diagrams on page 349 .

Technical data

The table below shows technical data.

Technical data	
Max. voltage	48 VDC
Max. current	4 A

Continues on next page

2 Installation and commissioning

2.5.10 Connection to MOTORS ON/MOTORS OFF contactor

Continued

Technical data	
Max. potential in relation to the cabinet earthing and other signal groups.	300 V
Signal class	Control signals

Procedure

Following procedure describes connection to the MOTORS ON/MOTORS OFF contactor.

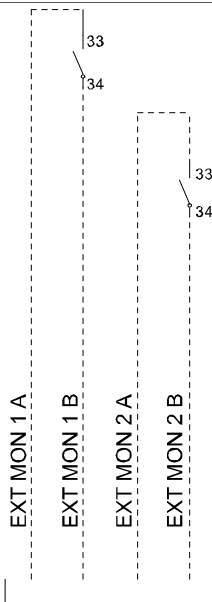
	Action	Info/Illustration
1	 DANGER Before doing any work inside the cabinet, disconnect the mains power. For more information, see Electrical safety on page 37 .	
2	Connect the wires to the contactor auxiliary blocks 33-34, according to the diagram to the right.	 <p>The diagram shows four vertical lines representing terminal blocks labeled EXT MON 1 A, EXT MON 1 B, EXT MON 2 A, and EXT MON 2 B. Dashed lines indicate connections to terminal blocks 33 and 34. For EXT MON 1 A and EXT MON 1 B, the connection goes to terminal 33. For EXT MON 2 A and EXT MON 2 B, the connection goes to terminal 34.</p>

xx0400001231

2.5.11 Connecting a FlexPendant

Location of FlexPendant connector

The FlexPendant connector on the IRC5 controller is located on the operator's panel on the controller, or on an external operator's panel.

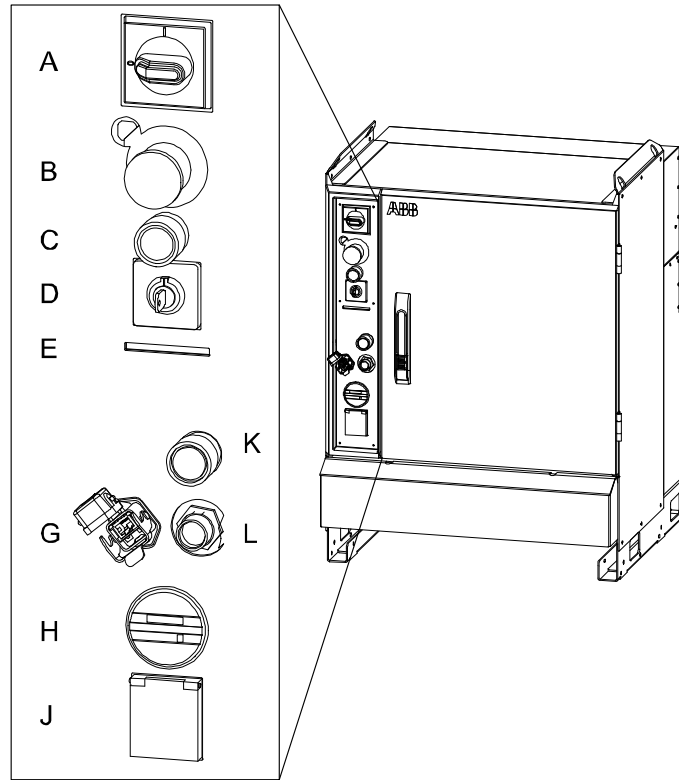

xx0600002782

L	FlexPendant connector (A22.X1)
---	--------------------------------

Connecting a FlexPendant



CAUTION

Always inspect the connector for dirt or damage before connecting it to the controller. Clean or replace any damaged parts.

	Action	Information
1	Locate the FlexPendant socket connector on the controller or operator's panel.	The controller must be in manual mode. If your system has the option Hot plug, then you can also disconnect in auto mode. See section Using the hot plug option on page 94 .
2	Plug in the FlexPendant cable connector.	
3	Screw the connector lock ring firmly by turning it clockwise.	

Continues on next page

2 Installation and commissioning

2.5.11 Connecting a FlexPendant

Continued

	Action	Information
4	The FlexPendant starts automatically when connected and verifies that it has the correct software installed. If an update is needed, this is shown.	Updating the add-in FlexPendant SxTPU4 Software on page 92

Updating the add-in FlexPendant SxTPU4 Software



Note

The add-in is only available for the FlexPendant with the emergency stop located at the connector. All other FlexPendant versions will automatically update their software via the controller (if needed).

The FlexPendant with the emergency stop located at the connector has an add-in that enables support for different RobotWare versions. This is the **FlexPendant SxTPU4 Software** add-in. The version of the add-in is shown during start-up.

When connecting the FlexPendant, the add-in verifies that it has support for the RobotWare version on the controller. If the RobotWare version is not supported by default, then the add-in requires an update. There are two methods to update the FlexPendant add-in. The update is distributed as a software package.

- The update can be installed using a USB drive.
- If the update is available on the controller, then the FlexPendant will update itself when connecting it to the controller.

Once the add-in is updated, the FlexPendant can be connected to other IRC5 controllers with the same RobotWare version without requiring additional updates.

Update using a USB drive

Use the following procedure to update the add-in using a USB drive.

- 1 Download the update from RobotStudio, in the tab **Add-Ins**.
- 2 Save the software package (.rspak) on a USB drive in the folder **SxTPU4**, located in the root folder.
- 3 With the FlexPendant connected to the controller, reset the FlexPendant with the USB drive connected.
- 4 The update starts automatically and takes approximately 3-4 minutes.

Update from the controller

Use the following procedure to update the add-in from the controller.

- 1 In RobotStudio, use **Installation Manager 6** to create or update a system on your controller. Add the product *FlexPendantSxTPU4Software*.
- 2 Connect the FlexPendant to the controller.
- 3 The update starts automatically and takes approximately 3-4 minutes.

Handling the FlexPendant cables

FlexPendant cables are allowed to be rolled up by hand with a minimum bending radius of 10 times the cable diameter. This also applies to the extension cable. For example, if the cable is 9.5 mm then it is allowed to roll it with a radius of 95 mm.

Continues on next page

Extension cables are not allowed to be used in chains.

2 Installation and commissioning

2.5.12 Using the hot plug option

2.5.12 Using the hot plug option

Hot plug option

The hot plug option makes it possible to:

- Disconnect the FlexPendant from a system in automatic mode and thereby run the system without a FlexPendant connected.
- Temporarily connect and operate a FlexPendant without interrupting the application running on the system.



WARNING

Pressing the hot plug button disables the emergency stop button on the FlexPendant. Only press the hot plug button while connecting or disconnecting the FlexPendant.



WARNING

A disconnected FlexPendant cannot initiate a protective or emergency stop. It must be stored out of sight so that it cannot be mistaken for being in use.

Connect and disconnect the FlexPendant using the hot plug button

The following procedure describes how to connect or disconnect the FlexPendant on a system in automatic mode using the hot plug button option.





Note

Do not switch to manual mode (or manual full speed mode) while the system is running without the FlexPendant. The FlexPendant must be connected when you switch to automatic mode otherwise you cannot confirm the mode change.

	Action	Information
1	Make sure that the system is in automatic mode.	
2	Press and hold the hot plug button.	A red lamp inside the button indicates when pressed.

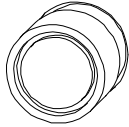
Continues on next page

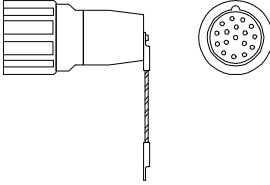
	Action	Information
3	Keep pressing the hot plug button and at the same time, switch the jumper plug with the FlexPendant plug.	<p data-bbox="970 353 995 387">A</p>  <p data-bbox="970 506 995 539">B</p>  <p data-bbox="970 600 1075 613">xx0600002784</p> <p data-bbox="970 636 1171 663">A: Hot plug button</p> <p data-bbox="970 672 1257 698">B: FlexPendant connector</p>  <p data-bbox="970 891 1075 904">xx0600002796</p> <p data-bbox="970 927 1107 954">Jumper plug</p>
4	Release the hot plug button.	Make sure that the button is not stuck in the actuated position since this disables the FlexPendant emergency stop button.
5	If the connected FlexPendant does not have support for the RobotWare version running on the controller, then a dialog is shown that the add-in must be updated. See Updating the add-in FlexPendant Sx-TPU4 Software on page 92 .	The three-position enabling device and emergency stop button are active even if the add-in dialog is shown.



Note

When the FlexPendant is disconnected, the jumper plug must be connected in its place.



Note

If the hot plug button is released while neither the jumper plug, nor the FlexPendant is connected, the robot movements will be stopped since the emergency stop chains are opened.

Limitations for messages on the FlexPendant

When using the hot plug option, the following limitations apply to messages on the FlexPendant:

Operator messages

Some applications may require input from the operator by using the FlexPendant (e.g. applications using RAPID instructions `TPReadNum`, `UIMsgBox`, etc.). If the application encounters such an operator message, program execution will wait. After connecting the FlexPendant you must then stop and start the program

Continues on next page

2 Installation and commissioning

2.5.12 Using the hot plug option

Continued

execution to be able to see and respond to these messages. They are not displayed automatically by just connecting the FlexPendant.

If possible, avoid using these types of instructions when programming systems that are using the hot plug button option.

Event log messages

When connecting the FlexPendant, event log messages can be viewed also for the period when the FlexPendant was disconnected, since these are stored on the controller.

2.5.13 Connectors on the computer unit

Overview of the computer unit

The following illustration shows an overview of the computer unit.

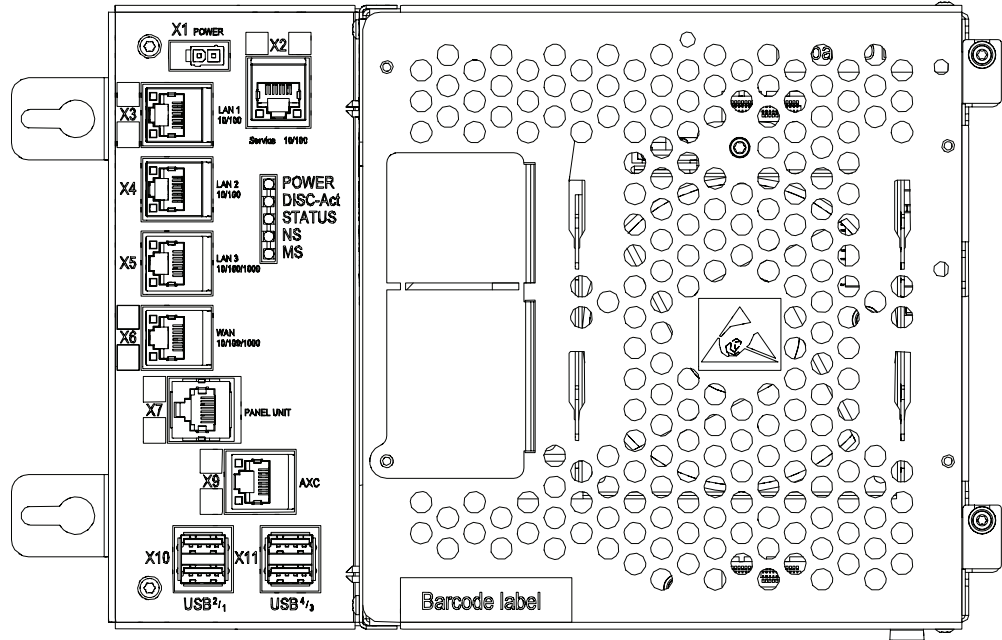

xx130000608

X1	Power supply
X2 (yellow)	Service (connection of PC).
X3 (green)	LAN1 (connection of FlexPendant).
X4	LAN2 (connection of Ethernet based options).
X5	LAN3 (connection of Ethernet based options).
X6	WAN (connection to factory WAN).
X7 (blue)	Panel unit
X9 (red)	Axis computer
X10, X11	USB ports (4 ports)



Note

It is not supported to connect multiple ports of the main computer (X2 - X6) to the same external switch, unless static VLAN isolation is applied on the external switch.

Service port test middle

The service port is intended for service engineers and programmers connecting directly to the controller with a PC.

Continues on next page

2 Installation and commissioning

2.5.13 Connectors on the computer unit

Continued

The service port is configured with a fixed IP-address, which is the same for all controllers and cannot be changed, and has a DHCP server that automatically assigns an IP-address to the connected PC.



Note

For more information about connecting a PC to the service port, see section *Connecting a PC to the controller in Operating manual - RobotStudio*.

WAN port

The WAN port is a public network interface to the controller, typically connected to the factory network with a public IP address provided by the network administrator.

The WAN port can be configured with fixed IP-address, or DHCP, from the **Boot application** on the FlexPendant. By default the IP-address is blank.

Some network services, like FTP and RobotStudio, are enabled by default. Other services are enabled by the respective RobotWare application.



Note

The WAN port cannot use any of the following IP-addresses which are allocated for other functions on the IRC5 controller:

- 192.168.125.0 - 255
- 192.168.126.0 - 255
- 192.168.127.0 - 255
- 192.168.128.0 - 255
- 192.168.129.0 - 255
- 192.168.130.0 - 255

The WAN port cannot be on a subnet which overlaps with any of the above reserved IP-addresses. If a subnet mask in the class B range has to be used, then a private address of class B must be used to avoid any overlapping. Please contact your local network administrator regarding network overlapping.

See the section about topic *Communication in Technical reference manual - System parameters*.



Note

For more information about connecting a PC to the WAN port, see section *Connecting a PC to the controller in Operating manual - RobotStudio*.

LAN ports

The LAN 1 port is dedicated for connecting the FlexPendant.

The LAN 2 and LAN 3 ports are intended for connecting network based process equipment to the controller. For example field buses, cameras, and welding equipment.

Continues on next page

LAN 2 can only be used as private network to the IRC5 controller.

Isolated LAN 3 or LAN 3 as part of the private network (only for RobotWare 6.01 and later)

The default configuration is that LAN 3 is configured as an isolated network. This allows LAN 3 to be connected to an external network, including other robot controllers. The isolated LAN 3 network has the same address limitations as the WAN network.



Note

The isolated LAN 3 cannot be used to connect to any HMI device (RobotStudio, Robot Web Services, or PC SDK client) since it does not support the protocol needed for communication.



Note

If isolated LAN 3 network is selected, then it may not be possible to use *Connected Services* on LAN 3 port, depending on which fieldbus protocol is used (EtherNet/IP or PROFINET).

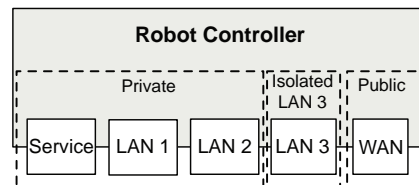

xx150000393

An alternative configuration is that LAN 3 is part of the private network. The ports Service, LAN 1, LAN 2, and LAN 3 then belong to the same network and act just as different ports on the same switch. This is configured by changing the system parameter *Interface*, in topic *Communication* and type *Static VLAN*, from "LAN 3" to "LAN". See *Technical reference manual - System parameters*.



Note

With this alternate configuration it is possible to use *Connected Services* on LAN 3 as the network is not isolated to one fieldbus protocol.

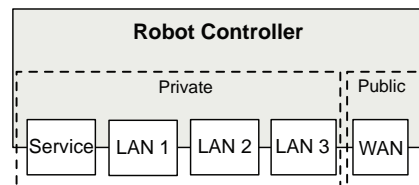

xx150000394



Note

For more information and examples of connecting to different networks, see *Application manual - EtherNet/IP Scanner/Adapter* or *Application manual - PROFINET Controller/Device*.

Continues on next page

2 Installation and commissioning

2.5.13 Connectors on the computer unit

Continued

USB ports

The USB ports are intended for connecting USB memory devices.



Note

It is recommended to use the USB ports USB¹ and USB² on the X10 connector for connecting USB memory devices.

The USB ports on the X11 connector are intended for internal use.

2.5.14 Connecting a serial channel to the controller

General

The serial channel is an option. To be able to connect a serial channel to the controller, the main computer needs to be equipped with the expansion board DSQC1003.

The expansion board has one RS232 serial channel, COM1, which can be used to communicate with process equipment.

The expansion board also enables the connection of a fieldbus adapter. For more information on how to connect a fieldbus adapter, see [Definition of fieldbuses, IRC5 on page 123](#).

Location

The serial channel connector is located on the expansion board in the computer unit as shown below.

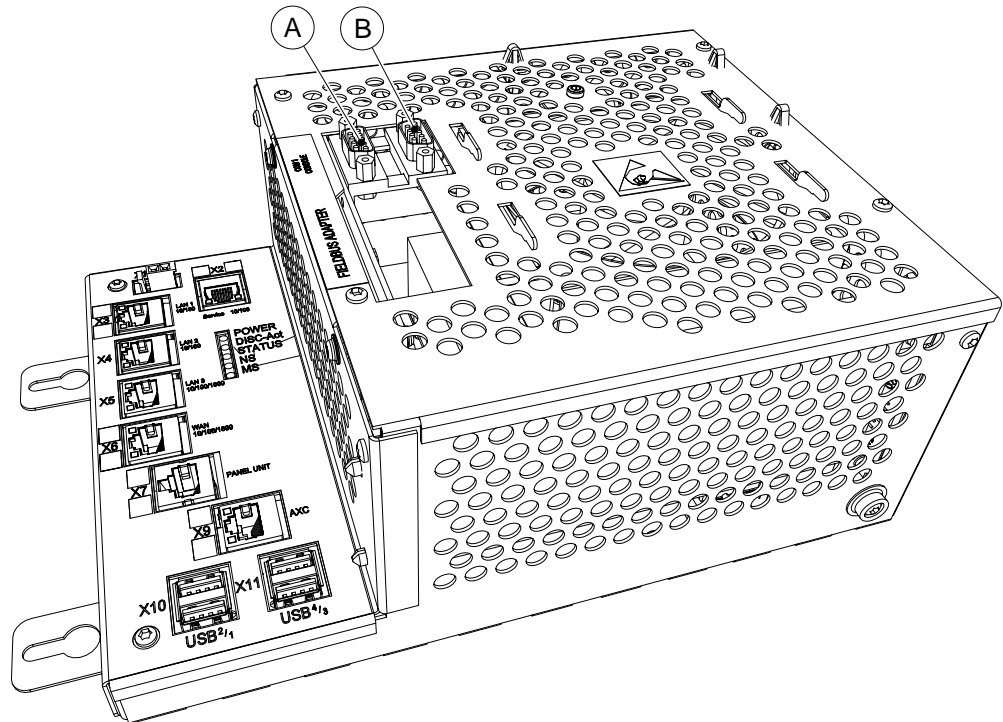

xx130000610

A	COM1
B	CONSOLE



Note

The CONSOLE connector is used for debugging purposes only.

Continues on next page

2 Installation and commissioning

2.5.14 Connecting a serial channel to the controller

Continued

Conversion of the RS232 channel

The RS232 channel can be converted to RS422 full duplex with an optional adapter, DSQC 615.

The RS422 enables a more reliable point to point communication (differential) over longer distances, from RS232 = 15m to RS422 = 120m.

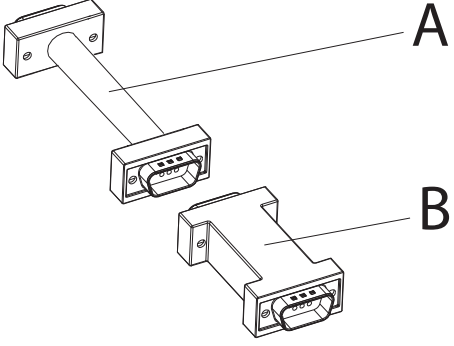
	Action	Info/Illustration
1	Connect the adapter to the serial channel connector.	<p>A cable is needed between the serial channel connector and the adapter.</p>  <p>xx130000854</p> <p>A cable B adapter</p>

2.5.15 Programmable stop functions

Stopping functions

There are different methods to stop the robot, in addition to manually initiated stops.

- Stop with system input signals
- Stop with RAPID instructions
- Other stops

Stop with system input signals

In the control system, it is possible to define system input signals to be set/reset through different interactions, for example, through I/O signals. See *Application manual - Controller software IRC5*.

The RAPID program cannot be started when any of the system input signals is high.

Pre-defined system input	Description
<i>Stop</i>	The RAPID program execution is stopped, and the manipulator is stopped on path with no deviation. This stop is similar to a normal program stop using stop button on the FlexPendant.
<i>SoftStop</i>	This is a faster stop of the manipulator than <i>Stop</i> . This stop is more stressing for the mechanics than normal stop, therefore there might be a minor deviation on path.
<i>QuickStop</i>	This is a faster stop of the manipulator than <i>Stop</i> and <i>SoftStop</i> . This stop is more stressing for the mechanics than normal stop or <i>SoftStop</i> , therefore there might be a deviation on path.
<i>Stop at End of Cycle</i>	Stops the RAPID program when the complete program is executed, that means when the last instruction in the main routine has been completed.
<i>Stop at End of Instruction</i>	Stops program execution after the current instruction is completed.

All of these stops are performed without using the brakes, and the power is never disconnected. The program execution can be continued directly, for example by activating a start signal if the stop signal is set low.



Note

Only safety rated input signals are allowed to be used for safety.

Continues on next page

2 Installation and commissioning

2.5.15 Programmable stop functions

Continued

Stop with RAPID instructions

There are several RAPID instructions available that stops the robot.



Instruction	Description	Arguments
SystemStopAction	Stops all robots in all tasks immediately.	<code>\Stop</code> : similar to a normal program stop with stop button. <code>\StopBlock</code> : as above, but to restart the PP has to be moved. <code>\Halt</code> : this is like a category 0 stop, i.e. it will result in motors off state, stop of program execution and robot movements in all motion tasks. The Motors on button must be pressed before the program execution can be restarted.
Stop	The current move instruction will be finished before the robot stops. A restart will continue the program execution.	<code>\NoRegain</code> : the robot will not return to the stop point when restarted, e.g. after having been jogged away. <code>\AllMoveTasks</code> : all robots will be stopped.
StopMove	The current move instruction will be stopped immediately as a normal program stop but the program execution will continue with the next instruction. <code>StartMove</code> must be executed to get the robot moving again.	<code>\Quick</code> : the stop will be a soft stop on path, as described for system input <code>SoftStop</code> , otherwise similar to a normal program stop. <code>\AllMotionTasks</code> : all robots will be stopped.
DebugBreak	The current move instruction and the program execution will be stopped immediately as a normal program stop. A restart of the program will continue the program execution.	
EXIT	The current move instruction and the program execution will be stopped immediately as a normal program stop. After stop the Program Pointer is lost and has to be reset to Main.	
EXITCYCLE	The current move instruction and program execution will be stopped immediately. The Program Pointer will be moved to Main and if running mode is continuous, the program will be restarted.	

Continues on next page

Instruction	Description	Arguments
SearchX	Search instructions can be programmed with arguments to stop the robot movement close to the point where a search hit was noticed. The program execution will continue with the next instruction.	<p><code>\Stop</code>: the robot will stop as fast as possible. This stop is performed by ramping down motion in each motor separate from each other, and as fast as possible. Since it will be without any coordination, the robot may slide off path fairly much.</p> <p><code>\PStop</code>: the robot will stop like after a normal program stop.</p> <p><code>\SStop</code>: the robot will stop on path but quicker than a normal program stop. This is similar to a system input <i>SoftStop</i>.</p> <p><code>\Sup</code>: the robot will continue to the <code>ToPoint</code>. If more than one search hit is found, an error will be reported.</p>

RAPID instructions are described in *Technical reference manual - RAPID Instructions, Functions and Data types*.

Other unexpected stops

Type of stop	Description
SysFail	In the control system there is a surveillance and monitoring function that can detect abnormal situations. In such cases a stop will be initiated. The robot controller must be restarted.
Power fail	In the control system there is a monitoring function that can detect power failure. In such cases a stop will be initiated.
Stop at collision	<p>In the control system there is a monitoring function that can detect collisions. In such cases a stop will be initiated.</p> <p> WARNING</p> <p>Special care must be taken when restarting a machine that is stopped due to a collision. The robot might make a limited move when restarted.</p> <p> WARNING</p> <p>The revolution counters might need to be updated after a collision to ensure path accuracy.</p>

2 Installation and commissioning

2.5.16 Connection of drive module

2.5.16 Connection of drive module

General

A controller that handles several robots or an application that requires more than three external axes needs extra drive modules (cabinets), one drive module per robot. Up to four drive modules can be used, including the control module (first cabinet that contains the main computer etc.).

This manual only describes the connector interface on the drive module. More information about installation of the drive module with the applications MultiMove can be found in *Application manual - MultiMove*.



Note

It is important that the earth connection point (C) is connected to a ground plane, in order to avoid disturbance.

Connectors

The following details the connectors on the front panel of the drive module cabinet.

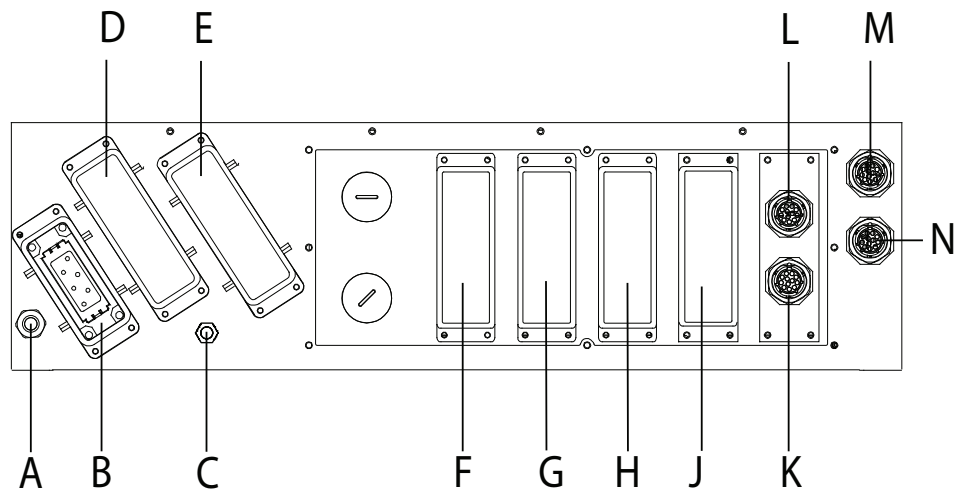

xx0600002931

	Description
A	Power connection to IRC5 controller cabinet
B	A4.X0: Mains connection to transformer
C	Earth connection point
D	A4.X1: Robot power connection
E	A4.X7: External axes power connection
F	A4.XX: Customer options
G	A4.XX: Customer options
H	A4.XX: Customer options
J	A4.XX: Customer options
K	Communication cabling between controller/drive module

Continues on next page

	Description
L	Communication cabling between controller/drive module
M	A4.XS41: Additional axes SMB connection
N	A4.XS2: Robot SMB connection

2 Installation and commissioning

2.5.17 Connection of Drive Module Disconnect, by limit switch

2.5.17 Connection of Drive Module Disconnect, by limit switch

General

This function enables you to temporarily disconnect a drive module and deactivate any robot or additional mechanical units connected to this module. The procedures are detailed below.

It is also possible to connect a remote switch to enable a Drive Module Disconnect. The required equipment and procedure for connection of a switch are specified below.



Note

The system diagnostics monitors the connection and disconnection of drive modules, and event log messages regarding these events will be stored in the event log when required. These messages are accessible using the FlexPendant or RobotStudio.



Note

This functionality cannot be used together with SafeMove, option 810-2.

Continues on next page

Location

The contactor interface board unit is located on the left hand side of the controller as shown below.

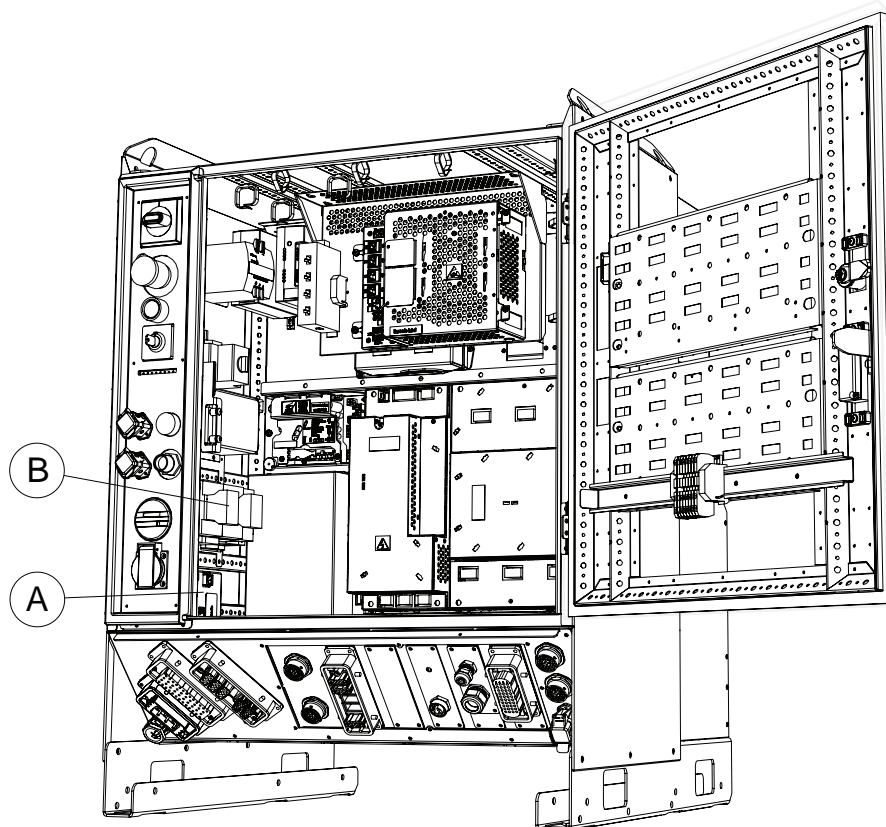

xx130000855

A	Contactor interface board
B	Contactors

Required equipment

The table below details the required equipment.

Equipment	Note
Wire	AWG20
Switch	24V 0.5A
<i>Operating manual - RobotStudio</i>	
<i>Operating manual - IRC5 with FlexPendant</i>	
Standard toolkit	
Circuit diagram	See Circuit diagrams on page 349 .

Continues on next page

2 Installation and commissioning

2.5.17 Connection of Drive Module Disconnect, by limit switch

Continued

Enabling Drive Module Disconnect in RobotStudio

The following procedures details how to enable the system for Drive Module Disconnect.

	Action
1	In the Configuration editor in RobotStudio, select the topic <i>Motion</i> .
2	Select the type <i>Drive Module User Data</i> .
3	Set the parameter for selected drive module to <i>YES</i> .
4	Restart the system.

Enabling Drive Module Disconnect with the FlexPendant

The following procedures details how to enable the system for Drive Module Disconnect.

	Action
1	In the Control panel on the FlexPendant, tap Topics , and select Motion .
2	Tap the type <i>Drive Module User Data</i> , and then tap to select the drive module.
3	Set the parameter for selected drive module to <i>YES</i> .
4	Restart the system.

Disconnecting the drive module

Use this procedure to disconnect a drive module.

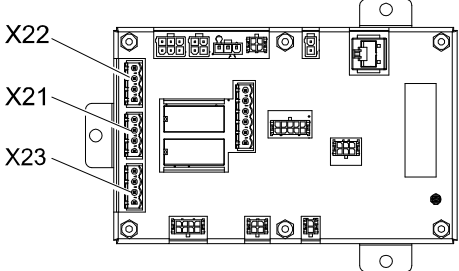
	Action	Note/illustration
1	Make sure that the system is in the MO-TORS_OFF state.	
2	Disconnect the connector X22 .	<p>It is also possible to use connector X21, but this is typically used for limit switches on the robot.</p>  <p>xx0500002087</p>

Reconnecting the drive module

Use this procedure to reconnect the drive module.

	Action	Note/illustration
1	Make sure that the system is in the MO-TORS_OFF state.	

Continues on next page

2 Installation and commissioning

2.5.17 Connection of Drive Module Disconnect, by limit switch

Continued

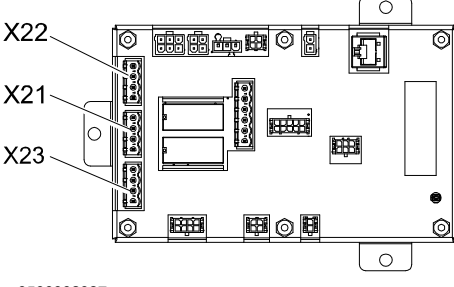
	Action	Note/illustration
2	Reconnect the X22 connector.	 <p>xx0500002087</p>
3	Move the program pointer to main in the RAPID-program where the disconnected mechanical units are active.	

Connect a remote switch

The following procedures details how to connect a remote switch.

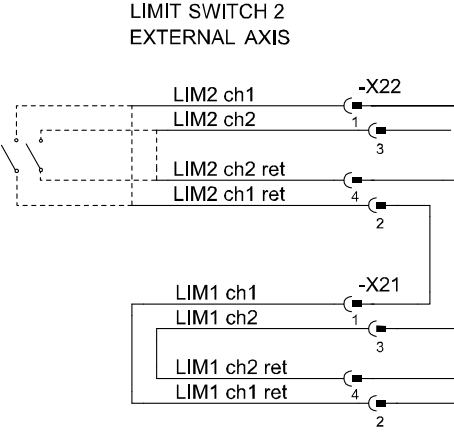
	Action	Note/illustration
1	Make sure that the system is in the MOTORS_OFF state.	
2	Disconnect the jumpers from the connector X22.	
3	Connect the wires to the connector X22 according to the diagram on the right.	<p>LIMIT SWITCH 2 EXTERNAL AXIS</p>  <p>LIMIT SWITCH 1 CONTROL CABLE</p> <p>xx0500002091</p>

2 Installation and commissioning

2.5.18 Connection of servo disconnect, by servo power switch

2.5.18 Connection of servo disconnect, by servo power switch

General

The IRC5 controller is pre-wired to accept a customer servo disconnect.



Note

Due to risk of voltage drop, the switch to the servo disconnect circuit should not be mounted more than 50 meters from the drive module cabinet.

Location

The contactor is found on the left hand side inside the controller as shown below.

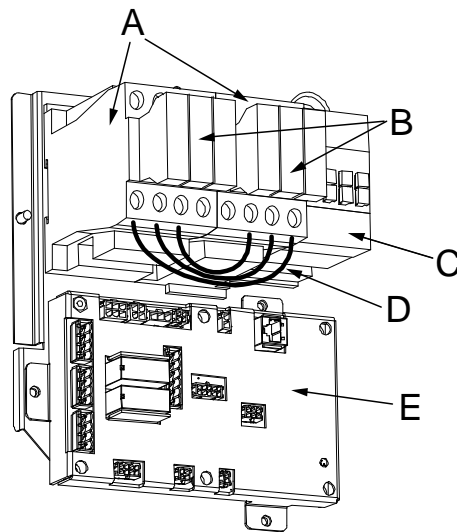

xx0400001058

A	MOTOR ON contactor K42 / K43
B	Contactor block3
C	Brake contactor
D	Jumper (4 pcs)
E	Contactor interface board

Required equipment

The table below details the required equipment.

Equipment	Note
Wire	AWG 10, brake AWG 16
Switch	500V 40 A, brake 24V 10A
Standard toolkit	
Circuit diagram	See Circuit diagrams on page 349 .

Continues on next page

2 Installation and commissioning

2.5.18 Connection of servo disconnect, by servo power switch

Continued



WARNING

It is recommended to also open the 24V to the brake (wire 489) to avoid accidental release of the brakes when the drive system is disconnected.

Procedure

Following procedure details how to connect a servo disconnect.

	Action	Note/Illustration
1	DANGER Before doing any work inside the cabinet, disconnect the mains power. For more information, see Electrical safety on page 37 .	
2	Remove the four jumpers between contactors R2 and R3	
3	Connect the wires according to the diagram on the right.	<p>xx0400001057</p> <ul style="list-style-type: none"> • A: MOTOR ON contactor K43 • B: Jumper (4 pcs) • C: MOTOR ON contactor K42 • D: Wires to external main switch • E: External switch

2 Installation and commissioning

2.5.19 Connecting a Limit switch override push button

2.5.19 Connecting a Limit switch override push button



DANGER

The Limit switch override is used to disconnect safety limitations. Make sure the Limit switch override function is not active longer than absolutely necessary.

If the option SafeMove is implemented, Limit switch override must never be used at all. The SafeMove safety controller has its own override function.

General

The override circuit enables the possibility to jog an axis out of a forbidden (limited) zone.

Limitations

The switch has to be placed inside the controller to eliminate the risk of electrical noise.

Required equipment

Equipment	Art. no	Note
Contact block (2 pcs)	3SFA 611 610 R1001	ABB CW Control
Push button (in Dual Cabinet)	1SFA 611 102 R1105	ABB CW Control
Connector X23	3HAC021085-001	
Wire		Cable AWG 20 Blue
Standard toolkit		This is detailed in section Standard toolkit, IRC5 on page 323 .
Circuit diagram		See Circuit diagrams on page 349 .



Note

The parts needs to be ordered separately from ABB and are not part of an option package.

Procedure

The following procedure details how to connect a Limit switch override circuit in the controller.

	Action	Note/illustration
1	 DANGER Before doing any work inside the cabinet, disconnect the mains power. For more information, see Electrical safety on page 37 .	

Continues on next page

2 Installation and commissioning

2.5.19 Connecting a Limit switch override push button

Continued

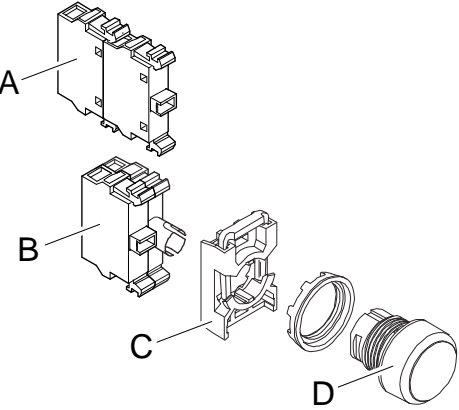
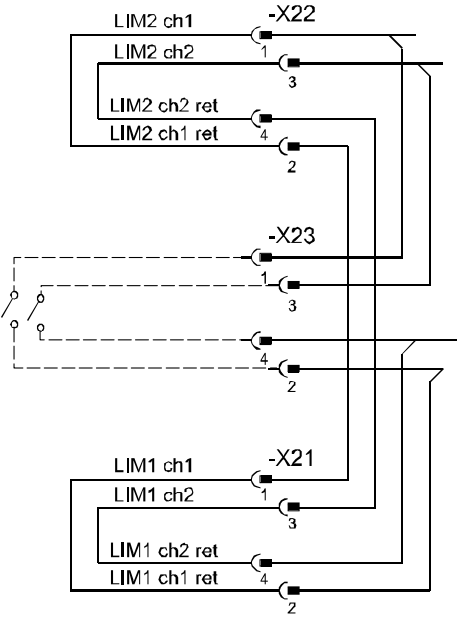
	Action	Note/illustration
2	<p>Attach two additional contact blocks on the existing push button (Motors on).</p> <p> Note</p> <p>There is only room for one additional contact block beside the two existing. Therefore, place one additional block on top of the other.</p>	 <p>xx0500002553</p> <ul style="list-style-type: none"> • A: Additional contact blocks • B: Existing contact, lamp blocks • C: Holder • D: Push button
3	<p>Connect wires from the contact blocks to the connector according to the diagram to the right.</p>	 <p>xx0500002556</p>

Continues on next page

2 Installation and commissioning

2.5.19 Connecting a Limit switch override push button

Continued

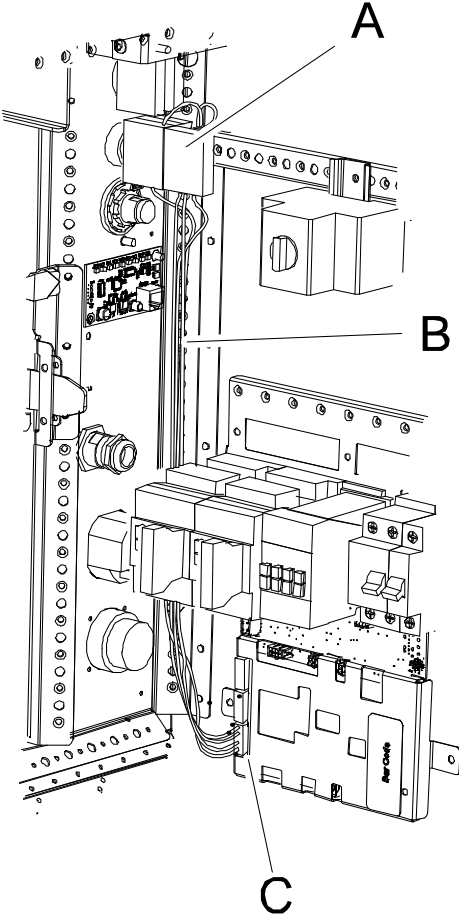
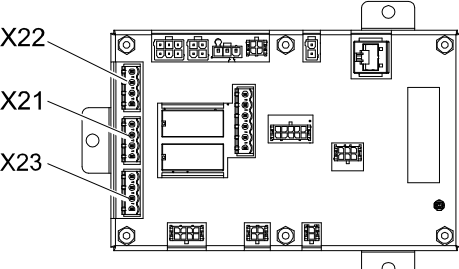
	Action	Note/illustration
4	Route the wires together with the existing harness on the left wall.	 <p>xx0500002557</p> <ul style="list-style-type: none">• A: Contact blocks• B: Wires• C: Connector X23
5	Fit the connector to the X23 connector on the contactor interface board.	 <p>xx0500002087</p>

2.6 Drive system

2.6.1 Drive functions, general

General

The robot is powered by power electronics found in the IRC5 controller. This also includes power electronics for driving additional axes.

Standard configurations

The drive system is available in different sizes depending on which robot to drive and other power requirements.

How the drive system is configured is described in section [Configuration of the drive system on page 118](#).

Replacing drive system parts

How to replace drive system parts is described in section [Replacement of drive units on page 262](#).

Installation of additional drive units

How to install additional drive units is described in section [Installation of additional drive units on page 180](#).

2 Installation and commissioning

2.6.2 Configuration of the drive system

2.6.2 Configuration of the drive system

General

The IRC5 Controller contains one Main Drive Unit and up to three Additional Drive Units, and in some cases an Additional Rectifier Unit. The allowed combinations of these, depending on the robot type, is specified below.

The robot system may also be equipped with up to three additional drive modules, which are described in section [Installation of additional Drive Module on page 187](#).

The drive unit configuration is detailed in *Application manual - Additional axes and standalone controller*, see [References on page 9](#).

Location

The drive system is located in the Single Cabinet Controller as shown below.

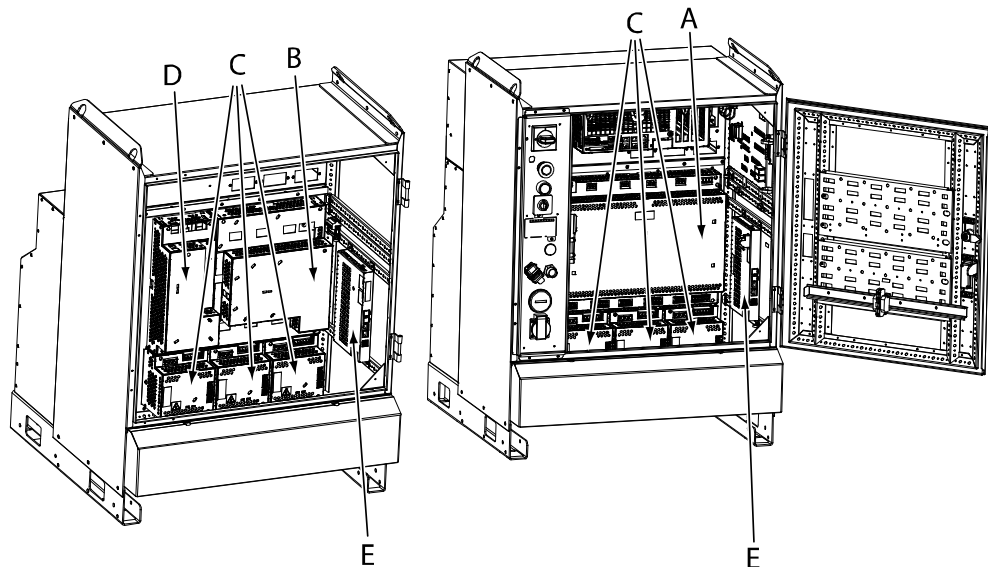

xx100000001

A	Main Drive Unit MDU-790A (for large robots)
B	Main Drive Unit MDU-430A (for small robots)
C	Additional Drive Units (for additional axes)
D	Additional Rectifier Unit (only used for additional axes in combination with small robots)

DC bus cables

Between the units are fitted DC bus cables, which are specified below:

Description	Art. no.	Note
DC bus cable	3HAC036612-001	For small robots up to IRB 1600-1660
	3HAC036612-002	Between drive unit and first additional drive unit
	3HAC036612-003	Between drive unit and second additional drive unit
DC bus cable	3HAC089023-001	Between drive unit and third additional drive unit
		For medium and large robots
DC bus cable	3HAC089023-001	Between drive unit and additional drive units

Continues on next page

Small robots (up to IRB 1600-1660)

The following illustration shows the drive units. The table specifies which units may be fitted in which positions.

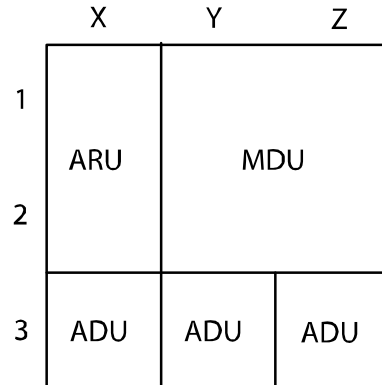

en080000293

Pos.	Identification	Description	Art. no.	Note
Y1, Y2, Z1, Z2	DSQC 406	Main Drive Unit MDU-430A	3HAC035301-001	
X1, X2	DSQC 417	Additional Rectifier Unit ARU-430A	3HAC035381-001	Required if any Additional Drive Unit is used.
X3	DSQC 664	Additional Drive Unit ADU-790A	3HAC030923-001	For first addition- al axis
Y3	DSQC 664	Additional Drive Unit ADU-790A	3HAC030923-001	For second addi- tional axis
Z3	DSQC 664	Additional Drive Unit ADU-790A	3HAC030923-001	For third addition- al axis

Medium and large robots

The following illustration shows the drive units. The table specifies which units may be fitted in which positions.

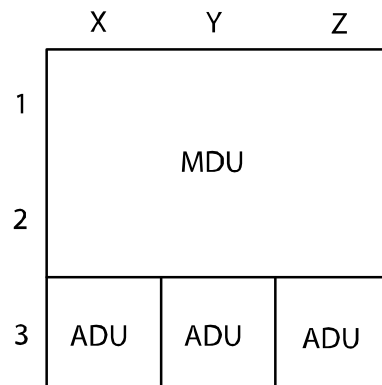

en080000292

Continues on next page

2 Installation and commissioning

2.6.2 Configuration of the drive system

Continued

Pos.	Identification	Description	Art. no.	Note
X1, X2, Y1, Y2, Z1, Z2	DSQC 663	Main Drive Unit MDU-790A	3HAC029818-001	
X3	DSQC 664	Additional drive unit ADU-790A	3HAC030923-001	For first additional axis
Y3	DSQC 664	Additional drive unit ADU-790A	3HAC030923-001	For second additional axis
Z3	DSQC 664	Additional drive unit ADU-790A	3HAC030923-001	For third additional axis

* IRB 8700 uses two ADU, in addition to the MDU, for the robot. Therefore, only one ADU can be used for an additional axis.

2.7 Memory functions

2.7.1 Memory functions

General

The controller is fitted with an SD-card memory containing ABB Boot Application software. The SD-card memory is located inside the computer unit.

For more information on how to replace the SD-card memory, see [Replacement of SD-card memory in computer unit on page 259](#).



Note

Only use SD-card memory supplied by ABB.



CAUTION

Reformatting the SD-card or modifying the disk partition can cause irreparable boot-up problems.

2 Installation and commissioning

2.7.2 Connecting a USB memory

2.7.2 Connecting a USB memory

Handling USB

Handling of USB memory is described in *Operating manual - IRC5 with FlexPendant*.

Location on FlexPendant

The USB port on the FlexPendant is located behind a rubber cover.

Location on main computer

The location of the USB ports on the main computer is shown by the following illustration:

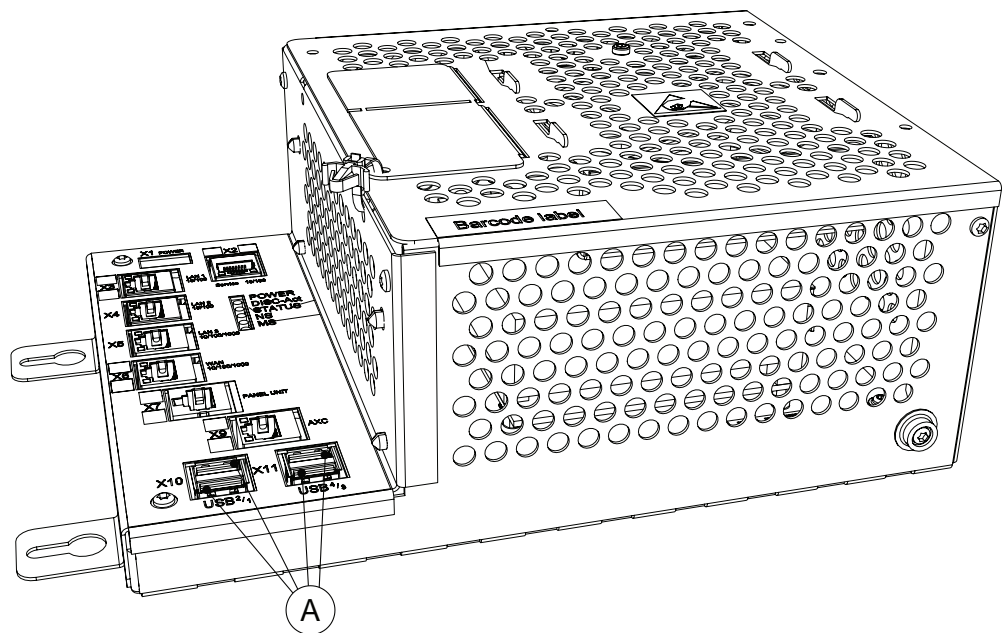

xx130000602

A	USB ports
---	-----------



Note

It is recommended to use the USB ports USB¹ and USB² on the X10 connector for connecting USB memory devices.

The USB ports on the X11 connector are intended for internal use.

2.8 I/O system

2.8.1 Definition of fieldbuses, IRC5

General

The IRC5 Controller may be fitted with a number of different fieldbus adapters and fieldbus master/slave boards.

In the standard form, no fieldbus is mounted to the controller.

Fieldbus master/slave boards

On the main computer unit there are slots available for installing a master/slave board.

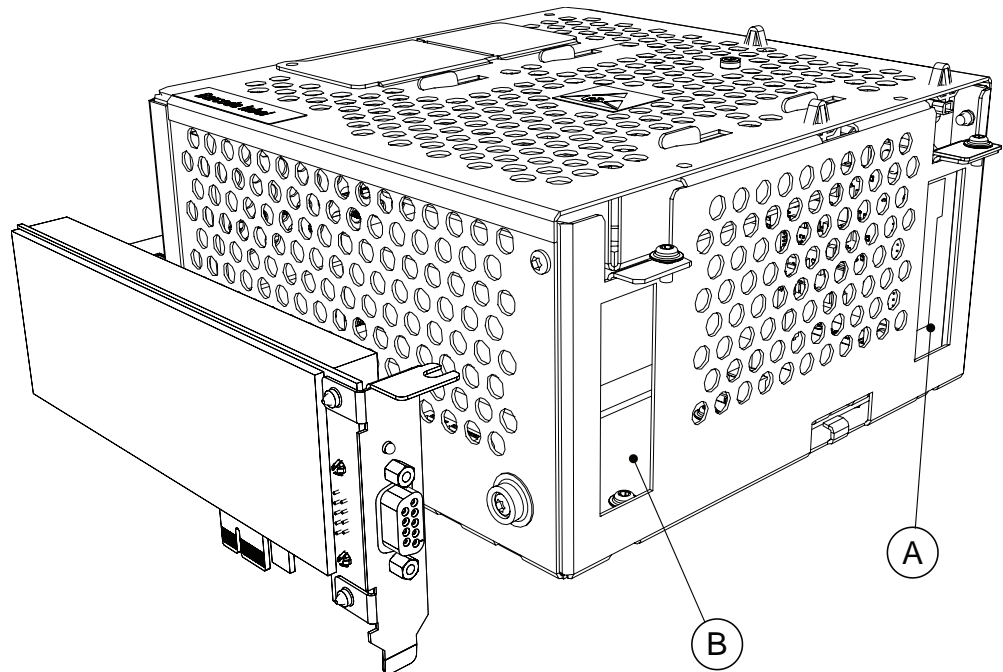

xx160000536

A	Slot for PCIeexpress boards
B	Slot for safety module (option SafeMove Pro or SafeMove Basic)

The following master/slave boards are available:

Description	Art. no.	Type designation
PROFIBUS Master PCIeexpress	3HAC044872-001	DSQC1005
DeviceNet Master/Slave PCIeexpress	3HAC043383-001	DSQC1006

Continues on next page

2 Installation and commissioning

2.8.1 Definition of fieldbuses, IRC5

Continued

Expansion board for fieldbus adapters

An expansion board needs to be installed to be able to fit a fieldbus adapter. On top of the main computer unit, there is one slot available for installing the expansion board.

The expansion board is also equipped with a serial channel. For more information on how to connect to the serial channel, see [Connecting a serial channel to the controller on page 101](#).

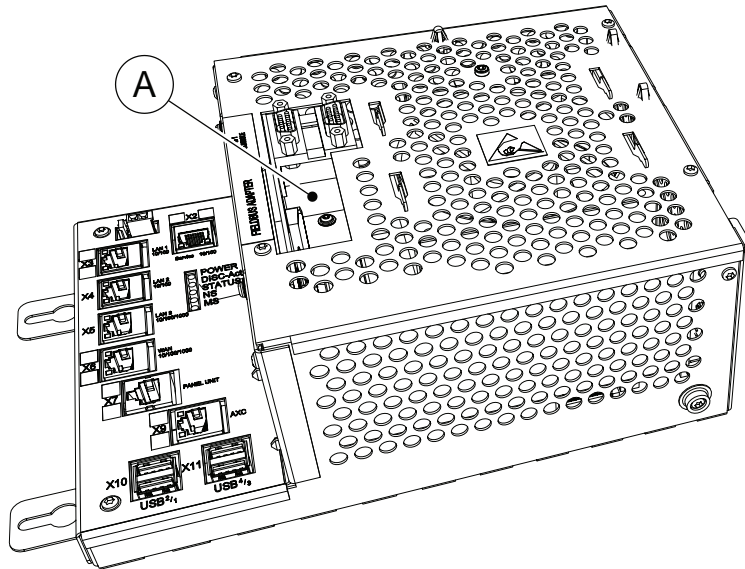

xx130000605

A	Assembled expansion board for fieldbus adapters, without adapter.	
Description	Art. no.	Type designation
AnybusCC / RS232 expansion board	3HAC046408-001	DSQC1003

Continues on next page

Fieldbus adapters

The fieldbus adapters are inserted into the expansion board on top of the main computer unit. There is one slot available for installing a fieldbus adapter.

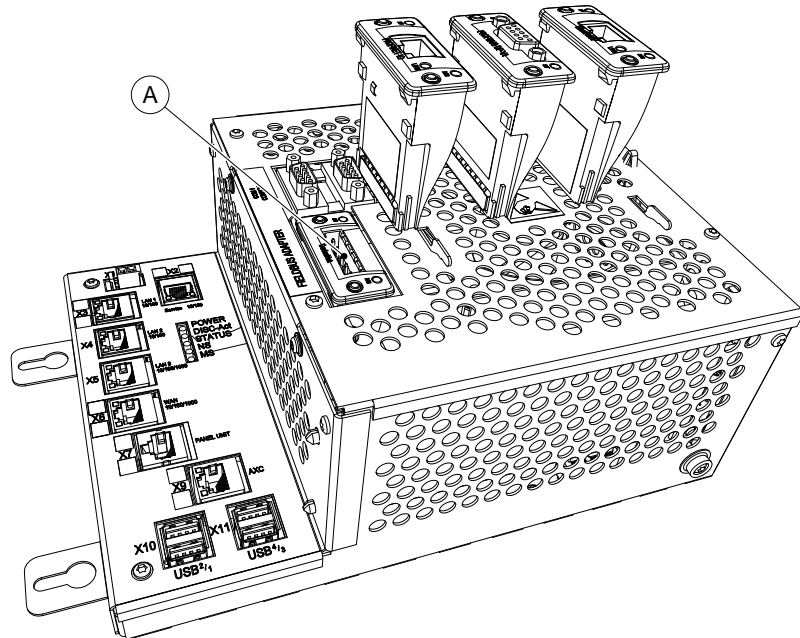

xx130000604

A	Slot for AnybusCC fieldbus adapters
---	-------------------------------------

Following fieldbus adapters are available:

Description	Art. no.	Type designation
AnybusCC DeviceNet slave	3HAC045973-001	DSQC1004
AnybusCC PROFIBUS slave	3HAC026840-001	DSQC 667
AnybusCC Ethernet/IP slave	3HAC027652-014	DSQC 669
AnybusCC PROFINET slave	3HAC031670-001	DSQC 688

References

For more information on how to install and configure the fieldbuses, see the respective fieldbus manual:

Manual title	Art. no.
<i>Application manual - DeviceNet Master/Slave</i>	<i>3HAC050992-001</i>
<i>Application manual - DeviceNet Anybus Slave</i>	<i>3HAC050993-001</i>
<i>Application manual - EtherNet/IP Anybus Adapter</i>	<i>3HAC050997-001</i>
<i>Application manual - EtherNet/IP Scanner/Adapter</i>	<i>3HAC050998-001</i>
<i>Application manual - PROFIBUS Anybus Device</i>	<i>3HAC050965-001</i>
<i>Application manual - PROFIBUS Controller</i>	<i>3HAC050966-001</i>
<i>Application manual - PROFinergy Device</i>	<i>3HAC050967-001</i>

Continues on next page

2 Installation and commissioning

2.8.1 Definition of fieldbuses, IRC5

Continued

Manual title	Art. no.
<i>Application manual - PROFINET Anybus Device</i>	<i>3HAC050968-001</i>
<i>Application manual - PROFINET Controller/Device</i>	<i>3HAC065546-001</i>

2.8.2 Scalable I/O devices

General

ABB Scalable I/O is a modular, compact, and scalable I/O system that consists of a base device, which is the minimum configuration, and add-on devices.

Up to four add-on devices can be controlled by each base device with maintained performance, and any combination of add-on devices is supported.

Communication

The digital base device communicates over the EtherNet/IP communication protocol to the robot controller or to other EtherNet/IP scanners. Up to 20 devices in total can be connected to the robot controller over EtherNet/IP. This includes digital base devices and other third-party I/O devices.

Node commissioning for other EtherNet/IP scanners

For other EtherNet/IP scanners, node commissioning needs to be done either using a dhcp server on the scanner network or setting a static IP address in the device with the help of third-party software. An initial volatile address can be obtained using the reset button. The TCP/IP Object can then be accessed for the purpose of this.

Options

When using the standard *Plug & Produce* interface, no additional RobotWare options or hardware options are required to connect to the robot controller.

When using the RobotWare option *EtherNet/IP Scanner/Adapter*, more configuration possibilities are available.

Device interfaces

The add-on devices have an optical interface and must be attached to a digital base device. The additional Ethernet port on the base device can be used to daisy chain any Ethernet based equipment on the same network, for example additional digital base devices.

Mounting

The I/O devices are designed to be mounted vertically on a mounting rail in an IP20 protected environment with normal air convention. Forced air is needed if the devices are mounted horizontally.

Continues on next page

2 Installation and commissioning

2.8.2 Scalable I/O devices

Continued

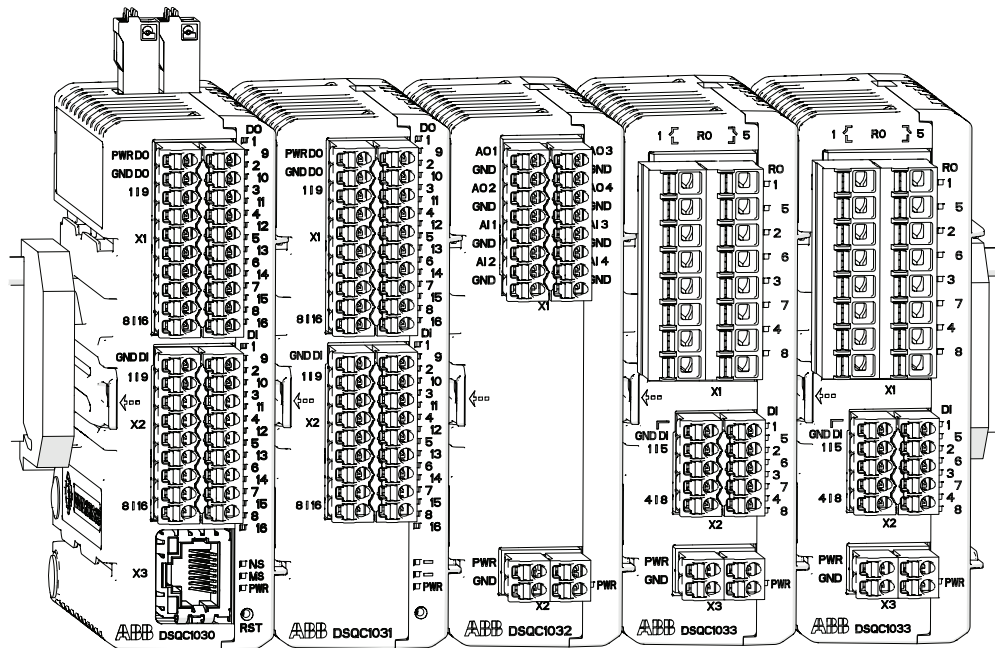

xx1600002032

Scalable I/O devices and parts

For more information about Scalable I/O device and parts, see [Scalable I/O devices on page 330](#).

2.8.3 DeviceNet I/O units

General

The IRC5 controller may be fitted with DeviceNet I/O or encoder units. These are configured in an identical way.

The IRC5 controller is prepared for up to four DeviceNet I/O units or encoder interfaces units. This means that the harness inside the controller is equipped with necessary connectors. The units are placed on the inside of the door, as shown in the illustration below.

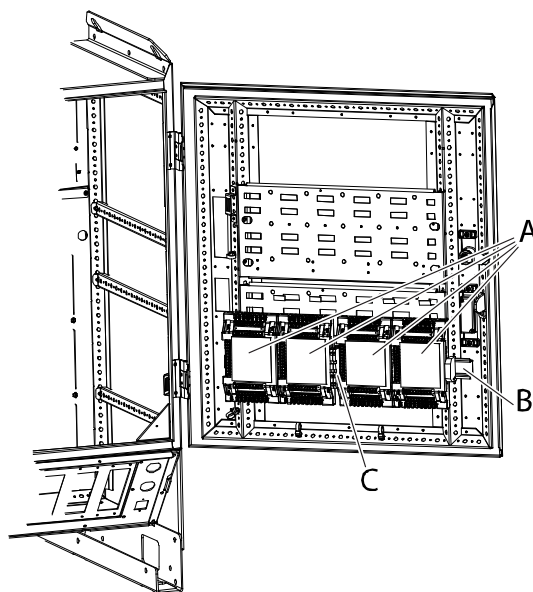

xx0500001859

A	I/O or encoder units
B	Mounting rail
C	Connection terminal XT31

Standard configuration

In the standard form, no fieldbus is mounted to the controller.

It is possible to connect any type of DeviceNet compliant I/O unit on the DeviceNet - master bus. All I/O units should comply with the DeviceNet standard and be conformance tested by ODVA.

DeviceNet I/O units and parts

The table below specifies the DeviceNet I/O units:

Description	Note
AD Combi I/O	DSQC 651
Digital I/O	DSQC 652

See [Spare parts on page 327](#) for the spare part numbers.

Continues on next page

2 Installation and commissioning

2.8.3 DeviceNet I/O units

Continued

Encoder interface units

The table below specifies the encoder interface units:

Description	Art. no.	Note
Encoder interface unit for conveyor tracking	3HNE 01586-1	DSQC 377B

Further information

The table below gives references to additional information:

Information:	Found in:
How to install the DeviceNet I/O units mechanically and electrically.	Fit the expansion board and/or field bus adapter according to Replacement of expansion board in the computer unit on page 248 and/or Replacement of fieldbus adapter in the computer unit on page 251 .
Allowed configurations of DeviceNet I/O units and how to setup the configurations.	<i>Technical reference manual - System parameters</i>
How to install the DeviceNet I/O unit software related in a new system.	The application manual for the different I/O buses respectively, see listing in Definition of fieldbuses, IRC5 on page 123 .
Detailed descriptions of all available DeviceNet I/O units.	The application manual for the different I/O buses respectively, see listing in Definition of fieldbuses, IRC5 on page 123 .

2.8.4 Conveyor tracking module

General

The conveyor tracking module, DSQC 2000 CTM-01, is a network based conveyor interface that provides connections for 4 encoders and 8 cameras. The camera connections can also be used for other sensor types, for example photocells. The module uses network communication to share conveyor speed and position data with one or more robot controllers.

The IRC5 controller can have one conveyor tracking module (option 1550-1) installed from delivery, but may also be equipped with 2 extra conveyor tracking modules (option 1551-1).

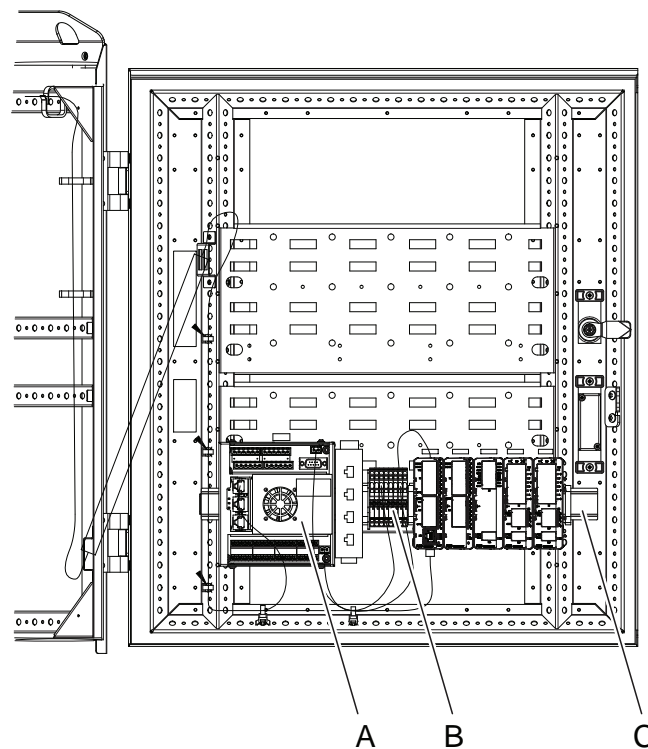

xx1800002637

A	Conveyor tracking module
B	Connection terminal XT31
C	Mounting rail

Encoder interface units

The table below specifies the encoder interface units:

Description	Art. no.	Note
DSQC2000 CTM-01	3HNA027579-001	Conveyor tracking module

Continues on next page

2 Installation and commissioning

2.8.4 Conveyor tracking module

RobotWare - OS

Continued

Description	Art. no.	Note
CONNECTOR KIT - DSQC2000	3HNA029345-001	Connector kit  Note The connector kit includes contacts for 2 encoders and 4 cameras. Two connector kits are needed to handle additional encoders and cameras.

Further information

The table below gives references to additional information:

Information:	Found in:
How to install and configure Conveyor Tracking.	<i>Application manual - Conveyor tracking,</i> <i>3HAC050991-001</i>

2.9 Installation of add-ons

2.9.1 Installation of external operator's panel, IRC5

Overview

External operator's panels can be either simply a panel or a panel box. See illustrations below.



Note

When ordering the external operator's panel as an add-on, the external operator's panel is delivered empty together with labels and blanking plugs.

When installing, the following components must be moved from the controller to the external operator's panel:

- Mode switch
- Motor ON button
- Emergency stop button

External operator's panel (option 733-3)

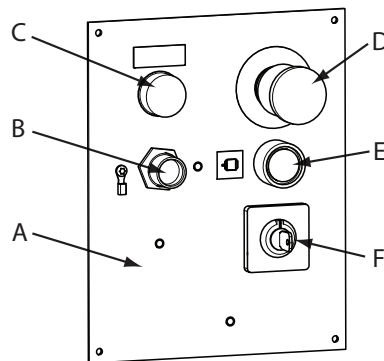

xx110000522

A	Front panel
B	FlexPendant connector
C	Blanking plug for actuator red
D	Emergency stop button
E	Motor ON button
F	Mode switch

Continues on next page

2 Installation and commissioning

2.9.1 Installation of external operator's panel, IRC5

Continued

External operator's panel box (option 733-4)

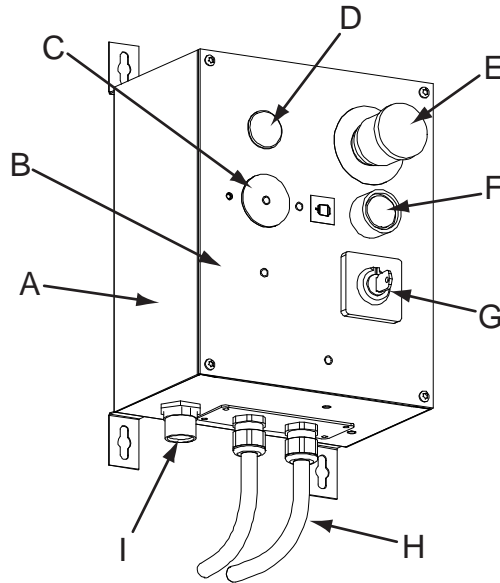

xx100000954

A	Wall cabinet
B	Front panel
C	Blanking plug for FlexPendant
D	Blanking plug for actuator red
E	Emergency stop button
F	Motor ON button
G	Mode switch
H	External operator's panel harness
I	FlexPendant connector

Required equipment

Equipment	Art. no.	Note
External operator's panel (733-3)	3HAC040643-003	
External operator's panel box (733-4)	3HAC040644-003	
External operator's panel cable	3HAC038767-001 3HAC038768-001 3HAC038769-001	7 m 15 m 30 m
Standard toolkit		The contents are defined in section, Standard toolkit, IRC5 on page 323
Circuit diagram		See Circuit diagrams on page 349 .

Continues on next page

2 Installation and commissioning

2.9.1 Installation of external operator's panel, IRC5

Continued

Procedure

The procedure below details how to install the external control panel.

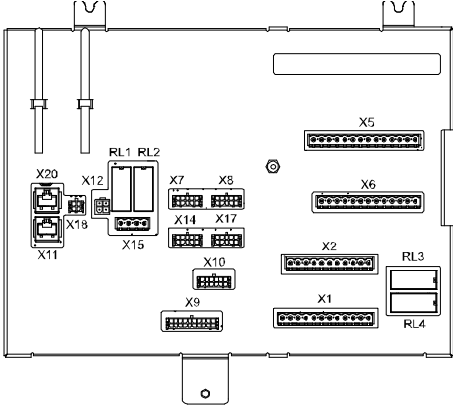
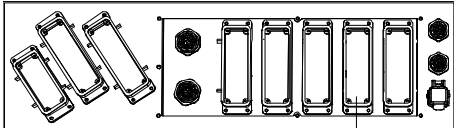
	Action	Info/Illustration
1	 <p>DANGER</p> <p>Before doing any work inside the cabinet, disconnect the mains power. For more information, see Electrical safety on page 37.</p>	
2	<p>Disconnect the cable from the ethernet connector for FlexPendant on the computer unit.</p>	
3	<p>Disconnect signal cabling from the panel board unit.</p> <p>Connectors:</p> <ul style="list-style-type: none"> • A21.X9 • A21.X10 	 <p>xx0500001890</p>
4	<p>Remove the following components together with the attached cable harness:</p> <ul style="list-style-type: none"> • S21.1, Mode switch • S21.2, Motor ON button • S21.3, Emergency stop button • XS4, FlexPendant connector 	<p>All components will be moved to the external operator's panel, except the FlexPendant connector and the cable harness which can be discarded.</p>
5	<p>Remove the cover to a free customer connector slot on the connection panel.</p>	<p>The illustration below shows the connection panel for the controller.</p>  <p>xx0500001960</p> <ul style="list-style-type: none"> • A: Customer connection slot
6	<p>Fit the harness from the external control panel to the empty slot with the four attachment screws.</p>	
7	<p>Connect the earth cable to the chassis.</p>	
8	<p>Connect the ethernet connector A31.X3 for the FlexPendant to the computer unit.</p>	
9	<p>Connect the signal connectors A21.X9 and A21.X10 to the connector X9 and X10 on the panel board unit.</p>	

Continues on next page

2 Installation and commissioning

2.9.1 Installation of external operator's panel, IRC5

Continued

	Action	Info/Illustration
10	Strap the cabling to the existing cable strapping inside the controller.	
11	Fit the labels and blanking plugs to the empty slots on the operator's panel.	
12	Fit the following components to the correct positions on the external operator's panel: <ul style="list-style-type: none">• S21.1, Mode switch• S21.2, Motor ON button• S21.3, Emergency stop button	
13	Fit the cabling to the panel box with the four attachment screws.	
14	Attach the XS4 connector to the external operator's panel, and connect the free ends of the harness to the components on the external operator's panel.	See Circuit diagrams on page 349 .
15	Connect the earth cable.	
16	Strap the cabling on the external operator's panel.	
17	Power on the controller and test the functionality of the Mode switch, Motor ON button, and the Emergency stop button.	

2.9.2 Installation of external enabling device

Overview

IRC5 is delivered with one enabling device but have the possibility to connect one additional external enabling device (cannot be ordered from ABB Robotics).

When an external enabling device is used together with the three-position enabling device on the teach pendant, both enabling devices must be enabled to be able to operate the manipulator in manual mode.

Connecting the external enabling device

The external enabling device must be connected to the panel board connector X6 pin 7-10 as shown in the figure below.

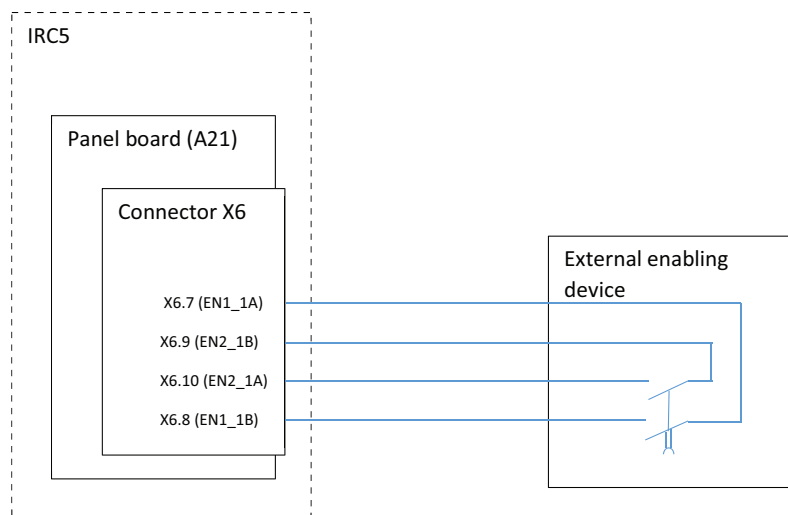

xx1500000534

The enabling device chain is enabled if X6 pin 7 is short circuited with X6 pin 8 at the same time as X6 pin 9 is short circuited with X6 pin 10.

Requirement on the external enabling device

The external enabling device connected to IRC5 must have the following characteristics:

- Redundant channels.
- Three-position enabling device. When the enabling device is pressed to the center position the enabling device chain must be enabled. When the enabling device is released or pressed to third position, the enabling device chain must be disabled.
- The enabling device must have a B10 value of at least 100000 cycles (less than 10% chance of failure before 100000 cycles).
- The mean time to dangerous failure (MTTF_d) of the external enabling device must be high enough to ensure that the external enabling device together

Continues on next page

2 Installation and commissioning

2.9.2 Installation of external enabling device

Continued

with IRC5's enabling device chain is above 55 years. See safety related performance for the enabling device chain below.

Performance of IRC5 original enabling device chain

The safety-related performance of the enabling device chain, without the external enabling device, is as follows:

- $MTTF_d$ for IRC5 enabling device chain is 80 years.
- IRC5's enabling device chain's calculated average probability of dangerous failure per hour (PFH_d) is 6.62×10^{-8} .
- IRC5's enabling device chain's design and structure is category 3.
- IRC5's enabling device chain's Diagnostic Coverage is medium ($90\% < DC_{avg} < 99\%$).
- The Common Cause Failure (CCF) is met according to the standard requirements.

2.9.3 Installation of Scalable I/O devices

Installation of Scalable I/O base device

The base device to be installed is shown in the illustration below.

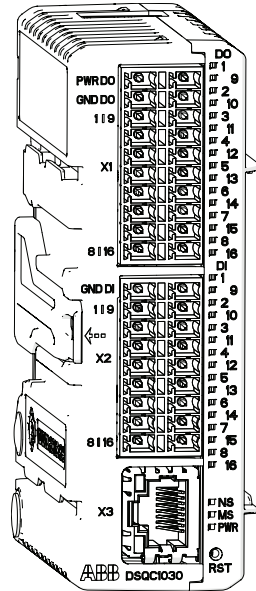

xx1600002033

Use this procedure to install the base device.



	Action	Note
1	 DANGER Before commencing any work inside the cabinet make sure that the main power has been switched off.	

Continues on next page

2 Installation and commissioning

2.9.3 Installation of Scalable I/O devices

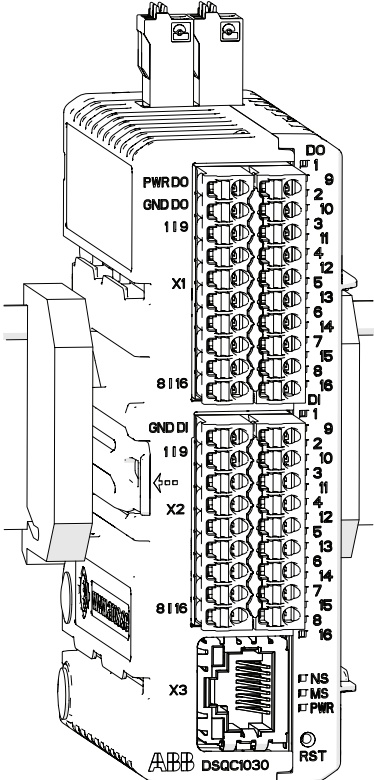
Continued

	Action	Note
2	Fit the device by snapping it onto the mounting rail.	 <p>xx1700000275</p>
3	Connect the Ethernet cable from the robot controller, or the EtherNet/IP scanner, to any of the connectors X3 or X5.	
4	Connect the logic power supply to connector X4.	For information about the pinout, see <i>Application manual - Scalable I/O</i>
5	Connect process power supply and GND to the input and output connectors X1 and X2.  Note The process power supply also powers the optical interface to the add-ons.	 CAUTION The process power supply must be supplied separately. Connecting the process power supply through the logical power supply connector may damage the device.
6	Connect wires to the inputs and outputs as required.	
7	Configure the device, see <i>Application manual - Scalable I/O</i> .	

Continues on next page

Installation of Scalable I/O add-on device

The add-on devices to be installed and the base device is shown in the illustration below.

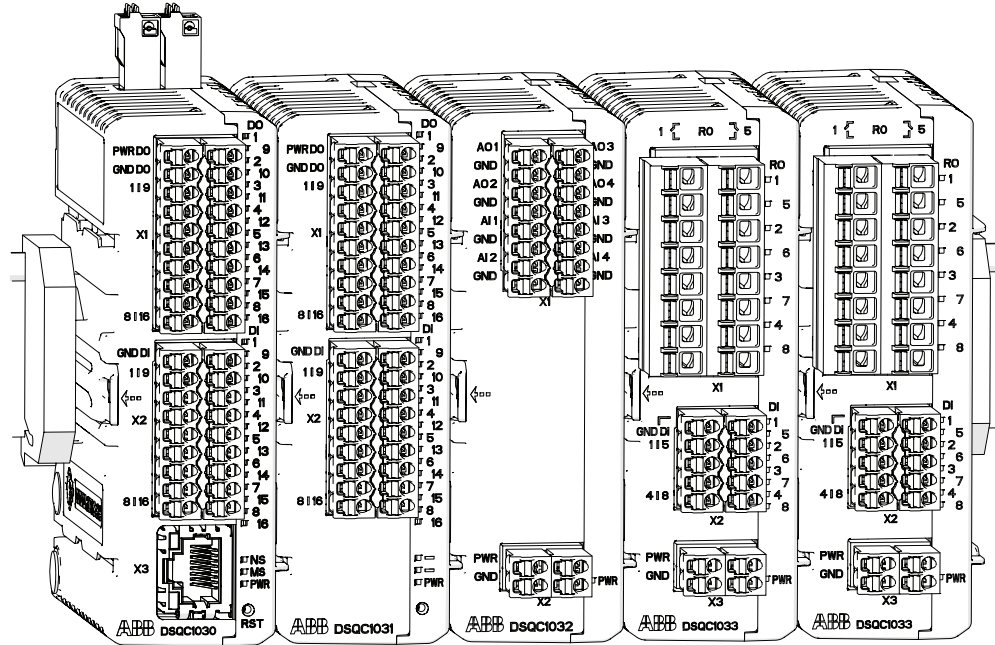

xx160002032

For more information about installing Scalable I/O add-on devices, please see *Application manual - Scalable I/O*.

2 Installation and commissioning

2.9.4 Installation of DeviceNet I/O, Gateways and encoder interface units, IRC5

2.9.4 Installation of DeviceNet I/O, Gateways and encoder interface units, IRC5

Location

The DeviceNet I/O units, Gateway or encoder interface units to be installed are shown in the illustration below.

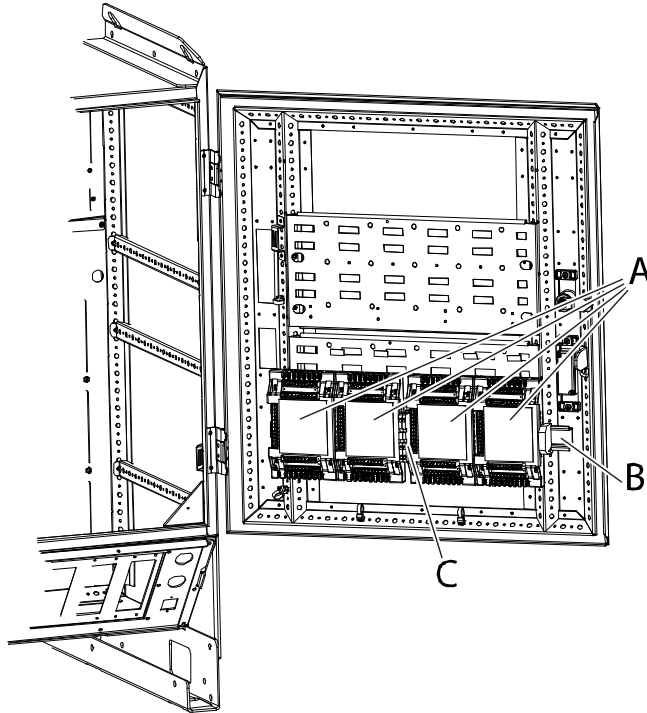

xx0500001859

A	I/O units, Gateways or encoder interface units
B	Mounting rail
C	Connection terminal XT31

Required equipment

Equipment	Article number	Note
DeviceNet I/O units, Gateways or encoder interface units		
<i>Application manual - DeviceNet Master/Slave</i>	3HAC050992-001	
Circuit diagram	See Circuit diagrams on page 349 .	

Continues on next page

Fitting

The procedure below details how to fit the units.

	Action	Note/Illustration
1	 DANGER Before doing any work inside the cabinet, disconnect the mains power. For more information, see Electrical safety on page 37 .	
2	Fit the DeviceNet/I/O unit by snapping it onto the mounting rail.	
3	Connect the DC supply to the board.	
4	Connect wires to the inputs and output connectors as required.	Described in the Application manual for the respective busses.

24 V power supply

I/O units are supplied with 24 V power from the connector XT31 (see previous illustration).

Parallel connection

The 24V coming from DSQC 662, terminal XT31.1, can not be increased by adding power from any other 24 V power supply (not even DSQC 609). There is no load levelling function that ensures current distribution. The unit will not be destroyed but the lifetime may be affected.

The parallel connection of two DSQC 609 is permitted (factory setting) but not more than two.

2 Installation and commissioning

2.9.5 Installation of conveyor tracking module

RobotWare - OS

2.9.5 Installation of conveyor tracking module

Location

The conveyor tracking module must be powered by a 24V power supply and connected to the Ethernet.

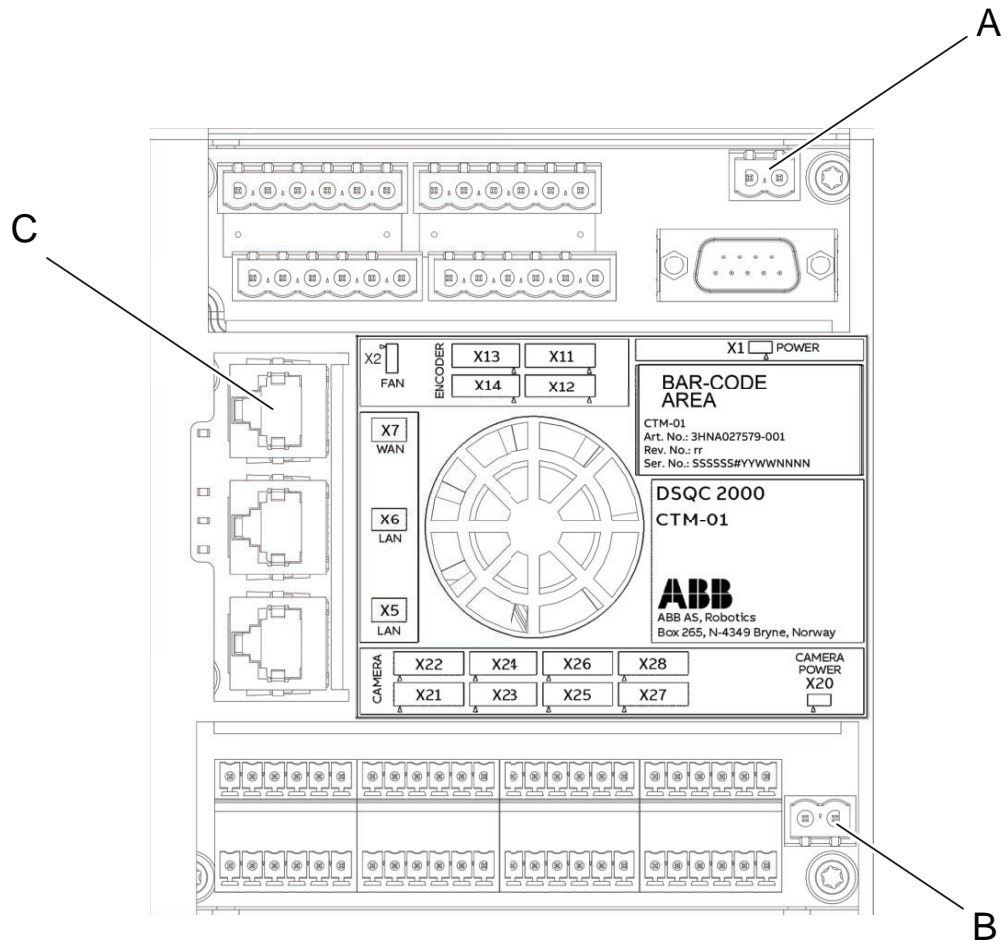

xx1800002638

A	X1, Power inlet 24VDC
B	X20, Optional camera power inlet 24VDC
C	X7 WAN, Ethernet connection

Continues on next page

2 Installation and commissioning

2.9.5 Installation of conveyor tracking module

RobotWare - OS

Continued

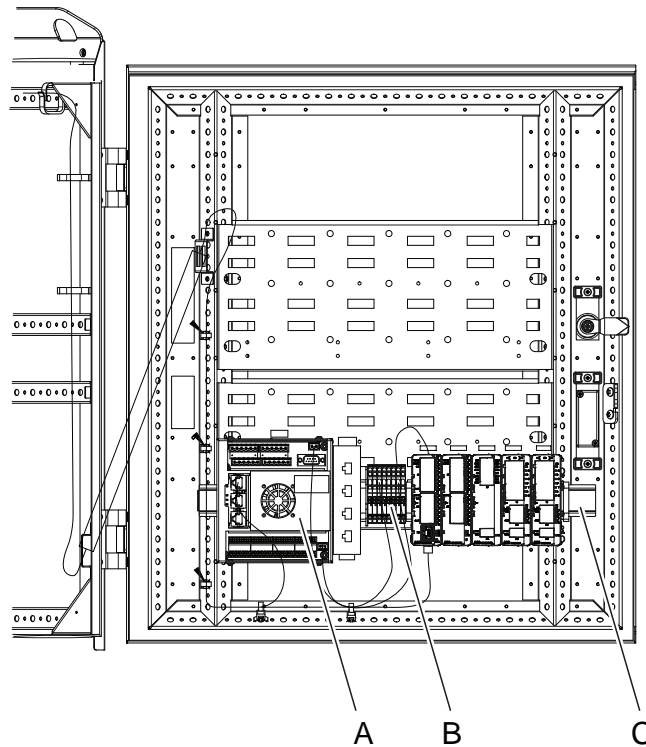

xx1800002637

A	Conveyor tracking module
B	Connection terminal XT31
C	Mounting rail

Required equipment

Equipment	Article number	Note
DSQC 2000 CTM-01	3HNA027579-001	
CONNECTOR KIT - DSQC 2000	3HNA029345-001	
<i>Application manual - Conveyor tracking</i>	<i>3HAC050991-001</i>	
Standard toolkit		See Standard toolkit, IRC5 on page 323 .
<i>Circuit diagram - IRC5</i>	<i>3HAC024480-011</i>	



Note

The connector kit includes contacts for 2 encoders and 4 cameras. Two connector kits are needed to handle additional encoders and cameras.

Continues on next page

2 Installation and commissioning



2.9.5 Installation of conveyor tracking module

RobotWare - OS

Continued

Fitting

The procedure below details how to fit the units.

	Action	Note/Illustration
1	 DANGER Before doing any work inside the cabinet, disconnect the mains power. For more information, see Electrical safety on page 37 .	
2	 ELECTROSTATIC DISCHARGE (ESD) The unit is sensitive to ESD. Before handling the unit read the safety information in section The unit is sensitive to ESD on page 49 .	
3	Fit the conveyor tracking module by snapping it onto the mounting rail.	
4	Connect 24VDC power supply from the XT31 to X1 (power inlet, main functions) and X20 (optional camera power inlet) on the conveyor tracking module.	
5	Connect the Ethernet cable to the connector X7 WAN on the conveyor tracking module.	The WAN port of the CTM must be connected to the same Ethernet network as the robot controllers.
6	Connect wires to the encoder and camera connectors as required.	Described in the <i>Application manual - Conveyor tracking</i> .

24V power supply

The unit is supplied with 24V power from the connector XT31 (see previous illustration).

Parallel connection

The 24V comes from DSQC 609, terminal XT31. There is no load levelling function that ensures current distribution. The unit will not be destroyed but the lifetime may be affected.

The parallel connection of two DSQC 609 is permitted (factory setting) but not more than two.

2.9.6 Installation of cooling fan harness axis 1 and 2

General

If the robot is equipped with cooling fans on one or more axes, an additional harness is required inside the controller.

Locations in controller

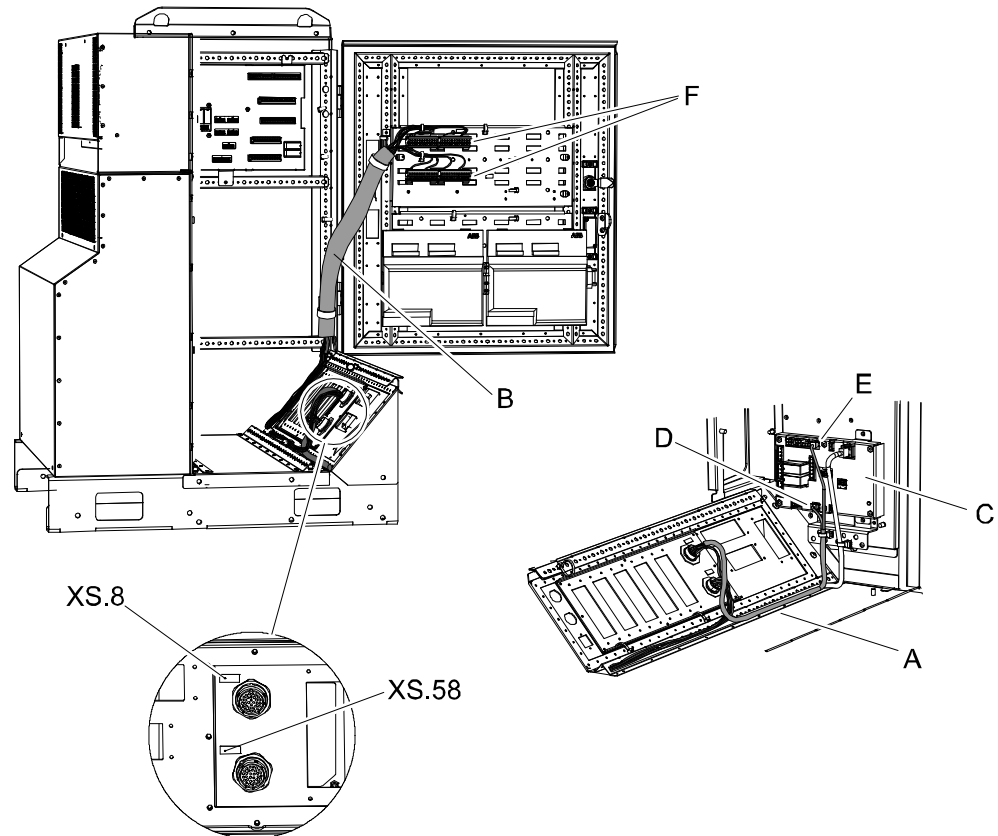

xx0600002686

A	Harness, cooling - Axis 1 and 2
B	Cable protection
C	Contactur interface board
D	Connector A43.X10
E	Connector A43.X11
F	Position switch terminals

Required equipment

Equipment	Article no.	Note
Harness, cooling - Axis 1 and 2 kit	3HAC025488-001	
Standard toolkit IRC5		See Standard toolkit, IRC5 on page 323 .
Circuit diagram		Circuit diagram - IRC5

Continues on next page





2 Installation and commissioning

2.9.6 Installation of cooling fan harness axis 1 and 2

Continued

Procedure

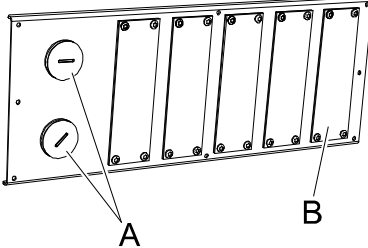
The following procedure details how to install the harness for cooling fans on the manipulator.

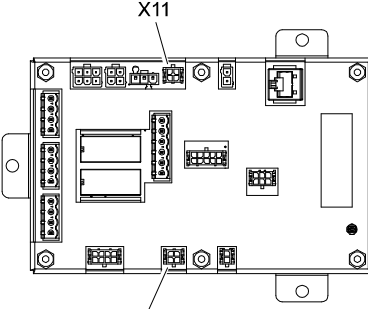
	Action	Note/Illustration
1	 DANGER Before doing any work inside the cabinet, disconnect the mains power. For more information, see Electrical safety on page 37 .	
2	 WARNING The unit is sensitive to ESD. Before handling the unit please read the safety information in the section The unit is sensitive to ESD on page 49	
3	Remove the two sealing plugs.	 <p>xx0600002688</p> <ul style="list-style-type: none"> • A: Sealing plug • B: Cover plate with gasket
4	Fit the two connectors XS.8 and XS.58 from the inside.	
5	Route the cable to the left and connect the harness connectors to the contactor interface board. <ul style="list-style-type: none"> • A43.X11 to X11 • A43.X10 to X10  CAUTION When connecting the Fan cables, it is important to consider the keying of the contacts. The locking mechanism on the cable contacts should be oriented away from the Panel Control Board center. Connecting this cable the wrong way will result in damaged components.	 <p>xx0600002690</p>
6	Route the wires with terminals to be mounted on the cabinet door inside the cable protection according to the illustration.	

Continues on next page

2 Installation and commissioning

2.9.6 Installation of cooling fan harness axis 1 and 2

Continued

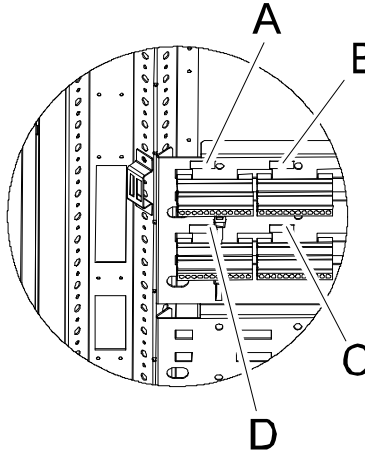
	Action	Note/Illustration
7	Fit the snap locking terminals to the plate on the cabinet door according to the illustration.	 <p data-bbox="1070 770 1177 786">xx0600002693</p> <ul data-bbox="1139 808 1230 936" style="list-style-type: none">XT8/8.1XT8/8.2XP58.2XP58.1

2 Installation and commissioning

2.9.7 Installation of the option Hot plug

2.9.7 Installation of the option Hot plug

Location

To be able to use the Hot plug function an additional hot plug button is needed. The figure below shows the location of the hot plug button on the controller.

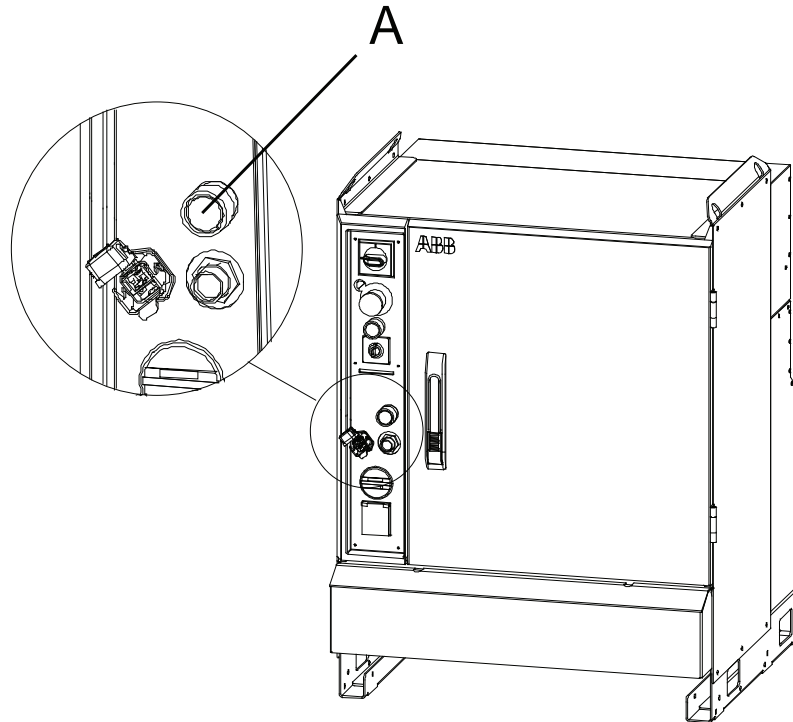

xx130000606

A	Hot plug button
---	-----------------



Required equipment

Equipment	Art. no.	Note
Hot plug	3HAC026225-002	
Standard toolkit		The contents are defined in section <i>Standard toolkit</i> .
Other tools and procedures may be required. See references to these procedures in the step-by-step instructions below.		These procedures include references to the tools required.
Circuit diagram		See Circuit diagrams on page 349 .

Continues on next page

Procedure Single Cabinet Controller

The procedure below details how to install the hot plug button in the controller.

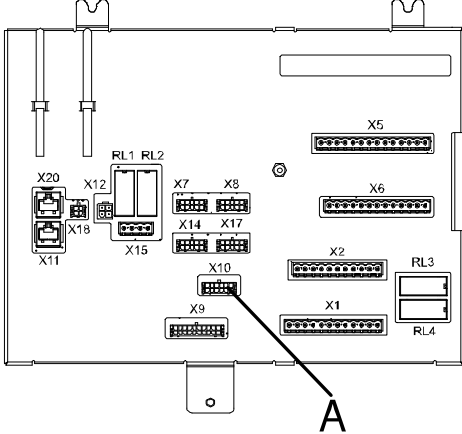
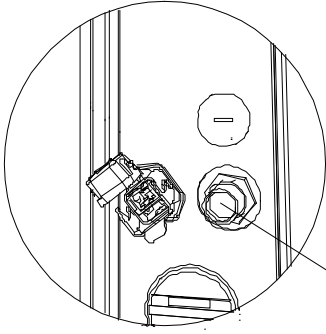
	Action	Note/Illustration
1	 <p>DANGER</p> <p>Before doing any work inside the cabinet, disconnect the mains power. For more information, see Electrical safety on page 37.</p>	
2	 <p>WARNING</p> <p>The unit is sensitive to ESD. Before handling the unit please read the safety information in the section The unit is sensitive to ESD on page 49</p>	
3	<p>Disconnect the cable from the ethernet connector for FlexPendant on the computer unit.</p>	
4	<p>Disconnect signal cabling from the panel board unit.</p>	 <p>xx0600002946</p> <ul style="list-style-type: none"> • A: Connector X10
5	<p>Remove the FlexPendant connector with harness from the Operator panel.</p>	 <p>xx0600002948</p> <ul style="list-style-type: none"> • A: FlexPendant connector

Continues on next page

2 Installation and commissioning

2.9.7 Installation of the option Hot plug

Continued

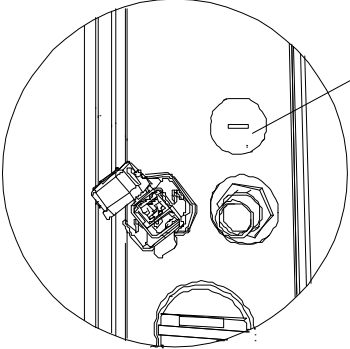
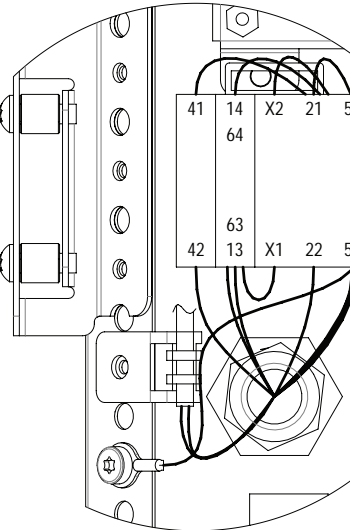
	Action	Note/Illustration																																				
6	Remove the plug that covers the hot plug hole.	 <p>xx0600002949</p> <ul style="list-style-type: none"> A: Plug 																																				
7	Fit the new FlexPendant connector and hot plug button with harness into the empty hole on the operator panel.																																					
8	Connect the ethernet connector for FlexPendant to the computer unit.																																					
9	Connect the signal connector A21.X10 to the panel board unit.																																					
10	Connect the cables to the hot plug button connector.	 <table border="1" data-bbox="1002 1594 1241 1908"> <thead> <tr> <th>Wire no.</th> <th>Conn. A</th> <th>Conn. B</th> </tr> </thead> <tbody> <tr> <td>207</td> <td>22</td> <td></td> </tr> <tr> <td>RD</td> <td>21</td> <td></td> </tr> <tr> <td>208</td> <td>42</td> <td></td> </tr> <tr> <td>OG</td> <td>41</td> <td></td> </tr> <tr> <td>209/BU1</td> <td>14</td> <td></td> </tr> <tr> <td>YE/BU1</td> <td>64</td> <td></td> </tr> <tr> <td>210/GN</td> <td>13</td> <td></td> </tr> <tr> <td>211/BU</td> <td>53</td> <td></td> </tr> <tr> <td>212/VT</td> <td>54</td> <td></td> </tr> <tr> <td>Bridge</td> <td>63</td> <td>X1</td> </tr> <tr> <td>213</td> <td>X2</td> <td>GND</td> </tr> </tbody> </table> <p>xx0600002953</p>	Wire no.	Conn. A	Conn. B	207	22		RD	21		208	42		OG	41		209/BU1	14		YE/BU1	64		210/GN	13		211/BU	53		212/VT	54		Bridge	63	X1	213	X2	GND
Wire no.	Conn. A	Conn. B																																				
207	22																																					
RD	21																																					
208	42																																					
OG	41																																					
209/BU1	14																																					
YE/BU1	64																																					
210/GN	13																																					
211/BU	53																																					
212/VT	54																																					
Bridge	63	X1																																				
213	X2	GND																																				

Continues on next page

2 Installation and commissioning

2.9.7 Installation of the option Hot plug

Continued

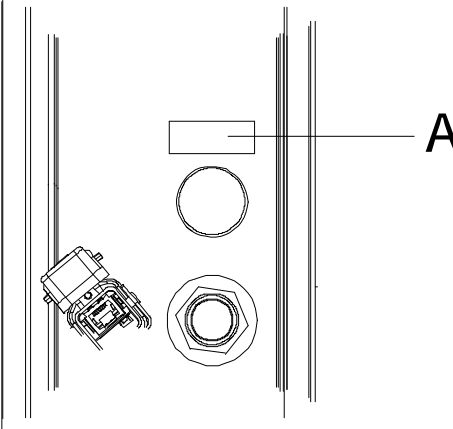
	Action	Note/Illustration
11	Place the warning label above the hot plug button.	 <p>xx0600002957</p> <ul style="list-style-type: none"> A: Warning label
12	Test the hot plug button function.	See section Test of hot plug button function on page 153 .

Test of hot plug button function

The procedure below details how to test the hot plug button function.

	Action	Note/Illustration
1	Make sure that the system is in automatic mode.	
2	Press the motors on button.	
3	Press and hold the hot plug button. <ul style="list-style-type: none"> Verify that the red lamp indicates when actuated. Verify that the system still has motors on. 	
4	Keep pressing the hot plug button and at the same time, switch the jumper plug with the FlexPendant plug. <ul style="list-style-type: none"> Verify that the system still has motors on. 	
5	Release the hot plug button. <ul style="list-style-type: none"> Verify that the system still has motors on. 	Make sure that the button is not stuck in the actuated position since it disables the FlexPendant emergency stop button.
6	Press and hold the hot plug button.	
7	Keep pressing the hot plug button and at the same time, switch the FlexPendant plug with the jumper plug.	
8	Release the hot plug button. <ul style="list-style-type: none"> Verify that the FlexPendant starts up correctly. Verify that the system still has motors on. 	
9	Switch to Manual mode.	Motors off
10	Confirm the mode change. <ul style="list-style-type: none"> Verify motors on. 	
11	Press the hot plug button. <ul style="list-style-type: none"> Verify motors off. 	

2 Installation and commissioning

2.9.8 Installing the EPS board DSQC 646 for Electronic Position Switches

2.9.8 Installing the EPS board DSQC 646 for Electronic Position Switches

General

To use the option Electronic Position Switches you need to install an EPS board in the robot controller. The procedure below will show how to install this board.



Note

It is not possible to have the options EPS and SafeMove installed at the same time - that is, only one of these two options can be installed and used.



WARNING

The safety controller has passive monitoring, i.e. it does not stop the robot. If an axis is outside its configured range, an output signal goes low. It is the responsibility of the installation personnel to connect the output signals in such a way that the robot is stopped if there is a risk of a dangerous situation.

Illustration

The EPS board should be mounted behind the axis computer.

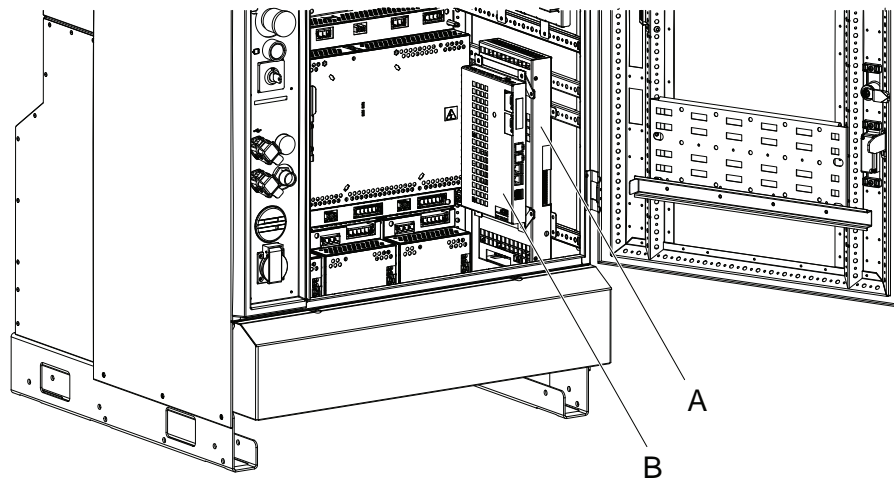



xx0600003203

A	EPS board
B	Axis computer

Continues on next page

Procedure

The procedure below details how to install an EPS board.

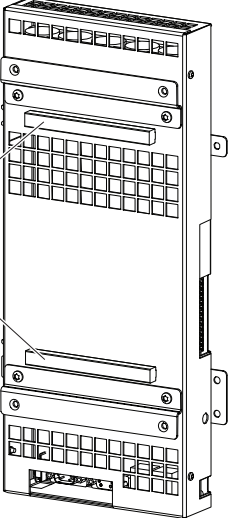
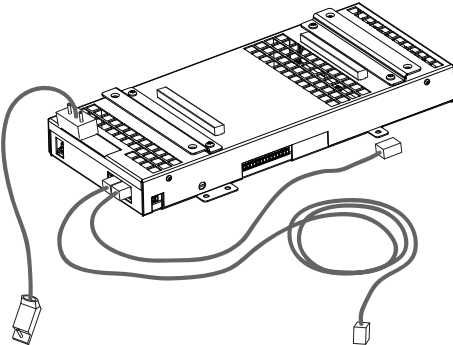
	Action	Note/illustration
1	 <p>DANGER</p> <p>Before doing any work inside the cabinet, disconnect the mains power. For more information, see Electrical safety on page 37.</p>	
2	 <p>ELECTROSTATIC DISCHARGE (ESD)</p> <p>The unit is sensitive to ESD. Before handling the unit read the safety information in section The unit is sensitive to ESD on page 49.</p>	
3	<p>If not already in place, fit the EMC strips on the EPS board.</p>	 <p>xx0700000087</p>
4	<p>Connect the short SMB cable and both Ethernet cables to the EPS board before mounting the board. These connections may be difficult to reach once the board is mounted.</p> <p>The two Ethernet connectors on the EPS board are interchangeable (it does not matter which is connected to the main computer and which is connected to the axis computer).</p>	 <p>xx0600003303</p>

Continues on next page

2 Installation and commissioning

2.9.8 Installing the EPS board DSQC 646 for Electronic Position Switches

Continued

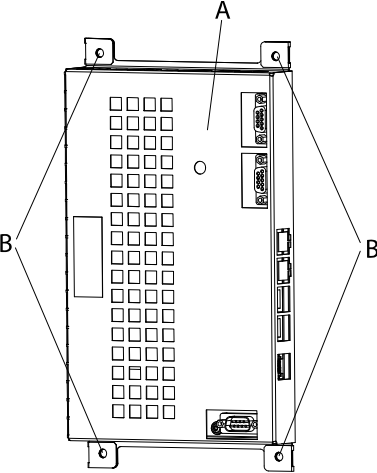
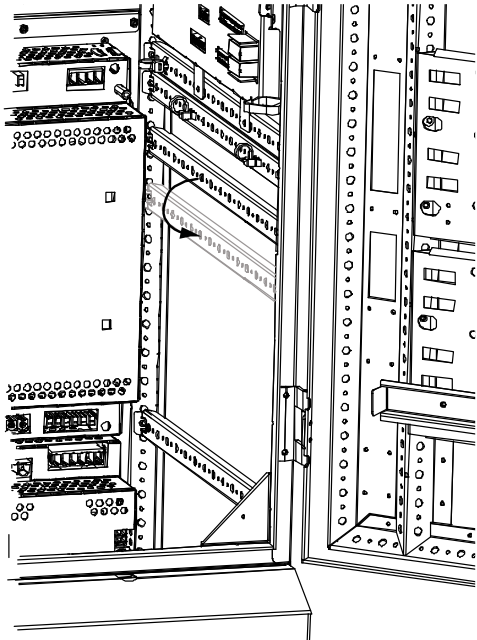
	Action	Note/illustration
5	Remove the attachment screws of the axis computer. Lift out the axis computer so that the EPS board can be fitted behind the axis computer.	 <p>xx0900000030</p> <ul style="list-style-type: none">• A: axis computer• B: attachment screws
6	Move the upper mounting rail: 1 Remove the Main Drive Unit. See Replacement of drive units on page 262 . 2 Move the upper mounting rail two steps (50 mm) down. 3 Replace the Main Drive Unit.	 <p>xx0900000737</p>

Continues on next page

2 Installation and commissioning

2.9.8 Installing the EPS board DSQC 646 for Electronic Position Switches

Continued

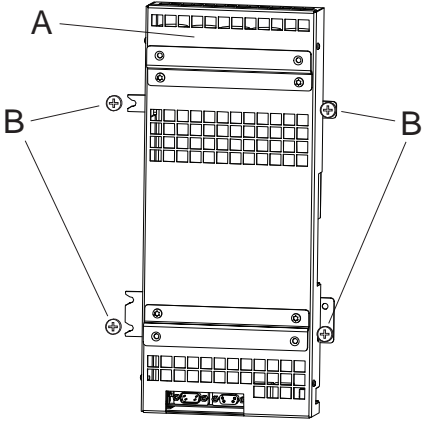
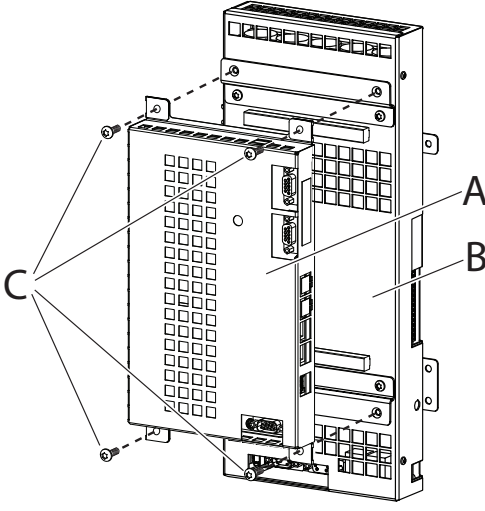
	Action	Note/illustration
7	Fit the EPS board in the same place as the axis computer was before.	 <p>xx0600003204</p> <ul style="list-style-type: none">• A: EPS board• B: attachment screws
8	Fit the axis computer on the EPS board.	 <p>xx0900000438</p> <ul style="list-style-type: none">• A: axis computer• B: EPS board• C: attachment screws

Continues on next page

2 Installation and commissioning

2.9.8 Installing the EPS board DSQC 646 for Electronic Position Switches

Continued

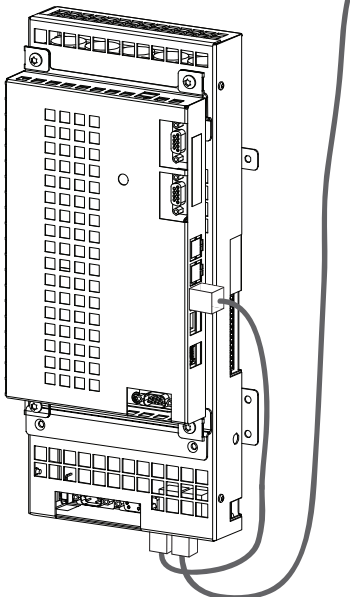
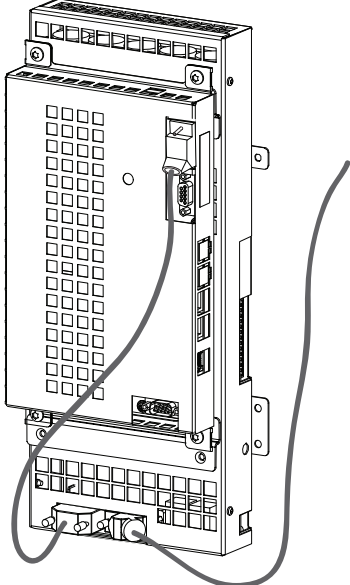
	Action	Note/illustration
9	<p>Remove the Ethernet cable between the main computer and the axis computer. Replace it with the long Ethernet cable from the EPS board to the main computer. Connect the short Ethernet cable between the EPS board and the axis computer.</p>	 <p>xx0600003218</p>
10	<p>Remove the SMB cable from the axis computer and connect it to the EPS board. Connect the SMB cable from the EPS board to the axis computer.</p>	 <p>xx0600003207</p>

Continues on next page

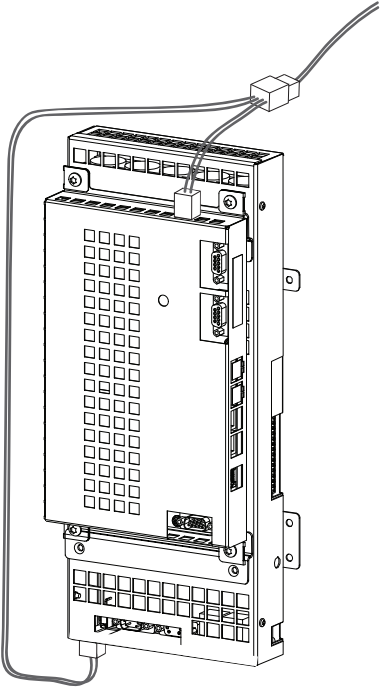
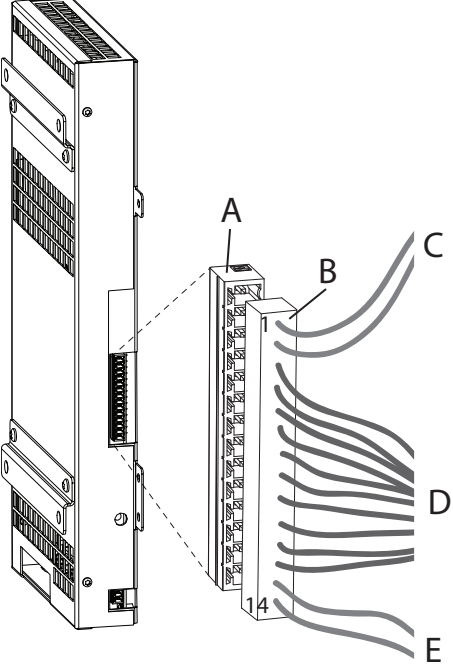
	Action	Note/illustration
11	<p>Remove the power cable from the axis computer and connect it to the split cable.</p> <p>Connect the split cable to the EPS board and the axis computer.</p>	 <p>xx0600003208</p>
12	<p>Connect signal cables to the plug contact, which is then connected to the I/O connector of the EPS board.</p> <ul style="list-style-type: none"> • Connect a power supply, 24 V to pin 1 and 0 V to pin 2. Check with a voltmeter that the voltage is 24 V between pin 1 and 2 on the Phoenix connector. • Connect the output signals from the EPS board (pin 3-12). • Connect the sync switch signals to pin 13 and 14. If dual channel wiring is not used, connect only pin 14. 	 <p>xx0600003209</p> <ul style="list-style-type: none"> • A: I/O Connector • B: Plug contact • C: Power supply • D: 5 safe outputs (10 signals) • E: Sync switch (dual signal)

2 Installation and commissioning

2.9.9 Installing the SafeMove board DSQC 647

2.9.9 Installing the SafeMove board DSQC 647

General

To use the option SafeMove you need to install a SafeMove board DSQC 647 in the robot controller. The procedure below will show how to install this board.



Note

It is not possible to have the options SafeMove and EPS installed at the same time - that is, only one of these two options can be installed and used.

Location

The SafeMove board should be mounted behind the axis computer.

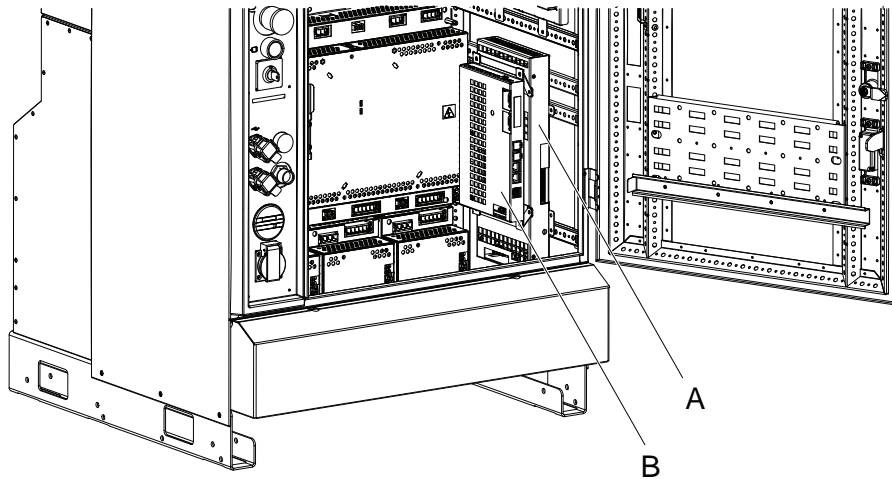



xx0600003203

A	SafeMove board
B	Axis computer

Procedure

The procedure below details how to install the SafeMove board.

	Action	Note/illustration
1	 DANGER Before doing any work inside the cabinet, disconnect the mains power. For more information, see Electrical safety on page 37 .	
2	 ELECTROSTATIC DISCHARGE (ESD) The unit is sensitive to ESD. Before handling the unit read the safety information in section The unit is sensitive to ESD on page 49 .	

Continues on next page

2 Installation and commissioning

2.9.9 Installing the SafeMove board DSQC 647

Continued

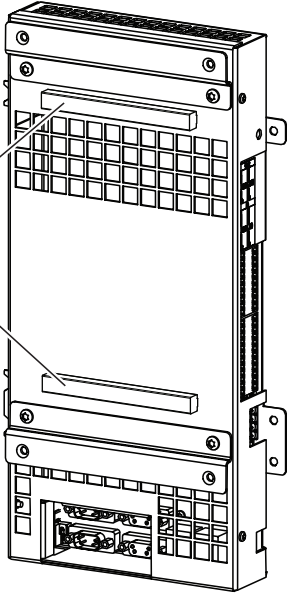
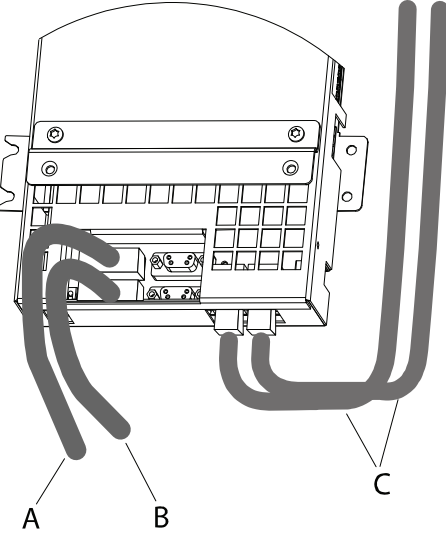
	Action	Note/illustration
3	If not already in place, fit the EMC strips on the SafeMove board.	 <p>xx0800000204</p> <ul style="list-style-type: none">• A: EMC strips
4	<p>Connect both SMB cables and both Ethernet cables to the SafeMove board before mounting the board. These connections may be difficult to reach once the board is mounted.</p> <p>The two Ethernet connectors on the SafeMove board are interchangeable (it does not matter which is connected to the main computer and which is connected to the axis computer).</p>	 <p>xx0800000103</p> <ul style="list-style-type: none">• A: SMB1 cable• B: SMB2 cable• C: Ethernet cables

Continues on next page

2 Installation and commissioning

2.9.9 Installing the SafeMove board DSQC 647

Continued

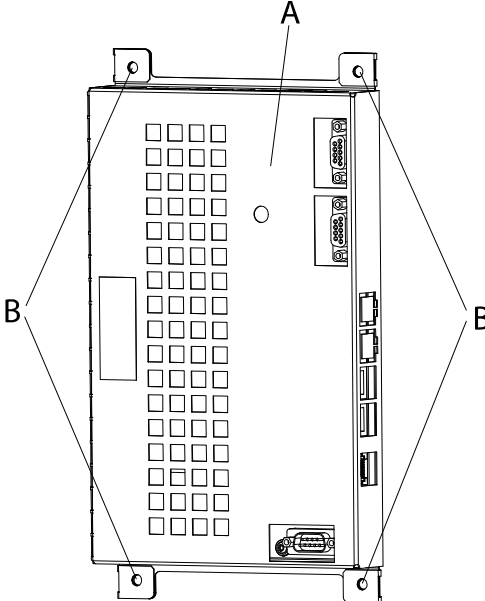
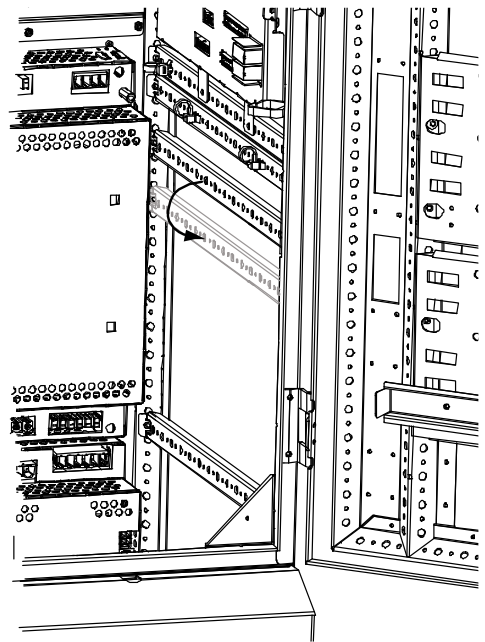
	Action	Note/illustration
5	Remove the attachment screws of the axis computer. Lift out the axis computer so that the SafeMove board can be fitted behind the axis computer.	 <p>xx0900000030</p> <ul style="list-style-type: none">• A: axis computer• B: attachment screws (4 pcs)
6	Move the upper mounting rail: 1 Remove the Main Drive Unit. See Replacement of drive units on page 262 . 2 Move the upper mounting rail two steps (50 mm) down. 3 Replace the Main Drive Unit.	 <p>xx0900000737</p>

Continues on next page

2 Installation and commissioning

2.9.9 Installing the SafeMove board DSQC 647

Continued

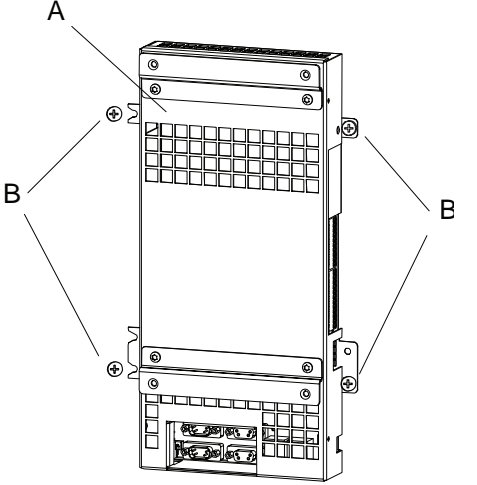
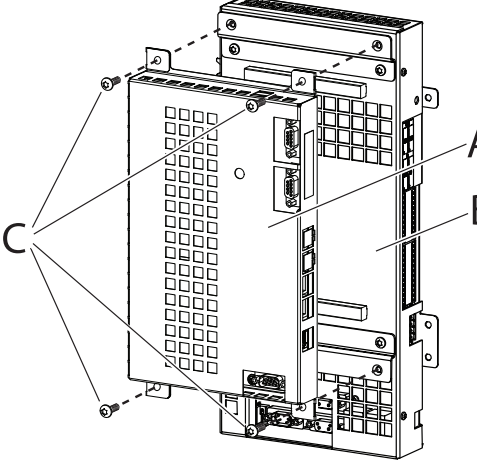
	Action	Note/illustration
7	Fit the SafeMove board in the same place as the axis computer was before.	 <p>xx0800000104</p> <ul style="list-style-type: none">• A: SafeMove board• B: attachments screws (4 pcs)
8	Fit the axis computer on the SafeMove board.	 <p>xx0900000441</p> <ul style="list-style-type: none">• A: Axis computer• B: SafeMove board• C: attachment screws (4 pcs)

Continues on next page

2 Installation and commissioning

2.9.9 Installing the SafeMove board DSQC 647

Continued

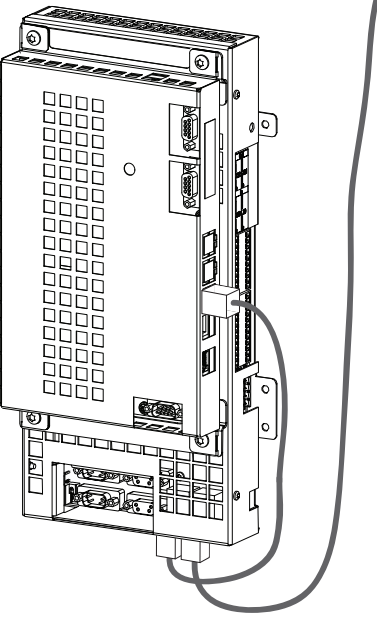
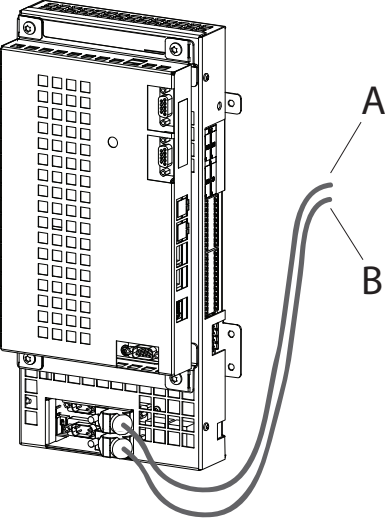
	Action	Note/illustration
9	Remove the Ethernet cable between the main computer and the axis computer. Replace it with the long Ethernet cable from the SafeMove board to the main computer. Connect the short Ethernet cable between the SafeMove board and the axis computer.	 <p>xx080000018</p>
10	Disconnect the SMB cables from the axis computer and connect them to the SafeMove board.	 <p>xx080000031</p> <ul style="list-style-type: none">• A: SMB1 cable (robot)• B: SMB2 cable (external axes)

Continues on next page

2 Installation and commissioning

2.9.9 Installing the SafeMove board DSQC 647

Continued

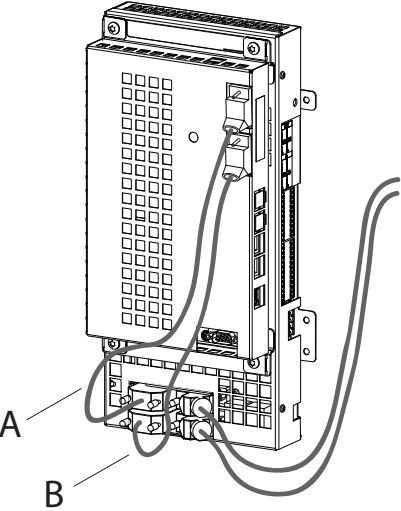
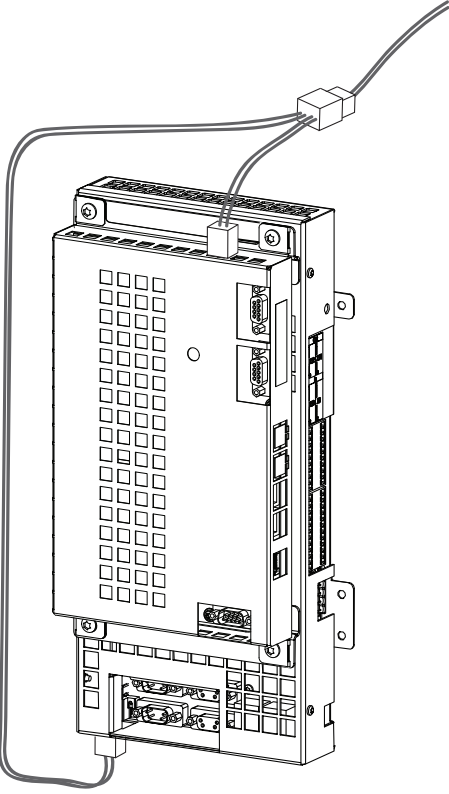
	Action	Note/illustration
11	Connect the SMB cables from the SafeMove board to the axis computer	 <p data-bbox="954 831 1061 853">xx080000032</p> <ul data-bbox="986 869 1189 936" style="list-style-type: none">• A: SMB1 cable• B: SMB2 cable
12	Disconnect the power cable from the axis computer and connect it to the split cable. Connect the split cable to the SafeMove board and the axis computer.	 <p data-bbox="954 1738 1061 1760">xx080000028</p>

Continues on next page

2 Installation and commissioning

2.9.9 Installing the SafeMove board DSQC 647

Continued

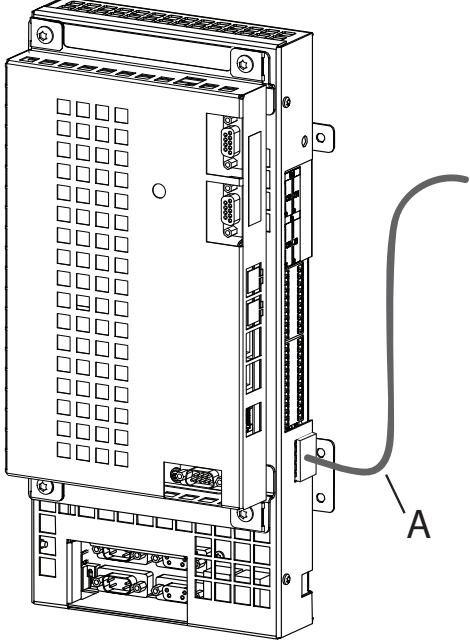
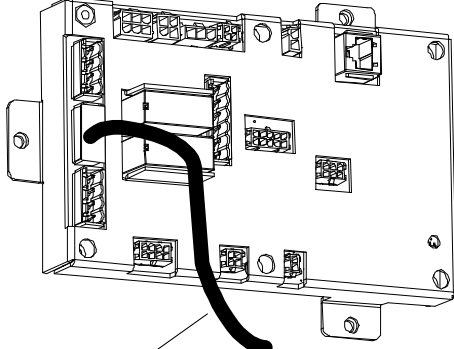
	Action	Note/illustration
13	Connect the limit switch cable between the SafeMove board (X13) and the contactor interface board (X21)	<p data-bbox="917 315 1109 342">SafeMove board:</p>  <p data-bbox="917 996 1029 1019">xx080000033</p> <p data-bbox="917 1030 1212 1057">Contactor interface board:</p>  <p data-bbox="917 1489 1029 1512">xx0800000105</p> <ul data-bbox="949 1523 1212 1556" style="list-style-type: none">• A: limit switch cable

Continues on next page

2 Installation and commissioning

2.9.9 Installing the SafeMove board DSQC 647

Continued

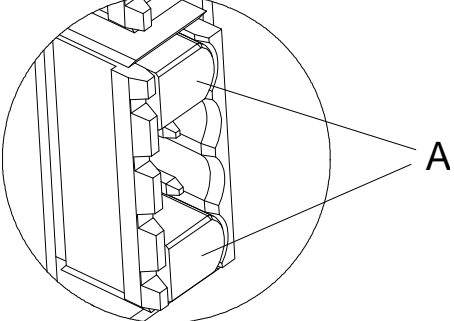
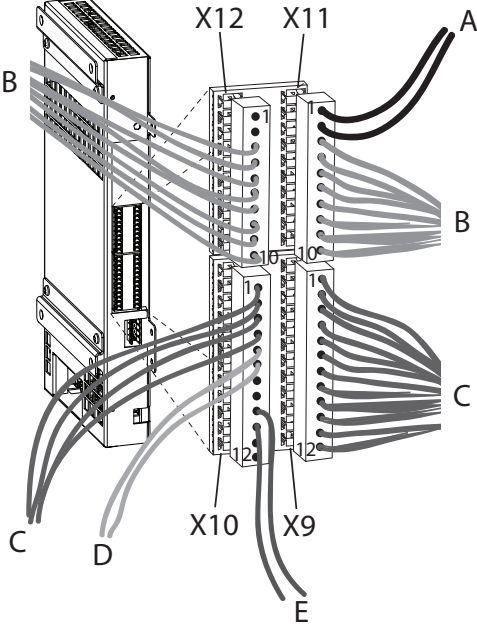
	Action	Note/illustration
14	Mount the plugs in the limit switch override contact (X23) at pin 1 and 4 on the contactor interface board.	<p>The limit switch override contact must be plugged and not used when using SafeMove.</p>  <p>xx0800000035</p> <ul style="list-style-type: none"> A: plug (2pcs)
15	Connect signal cables to the plug contacts, which is then connected to the I/O connector of the SafeMove board.	 <p>xx07000000640</p> <ul style="list-style-type: none"> A: Power supply B: 8 safe outputs (16 signals) C: 8 safe inputs (16 signals) D: Sync switch (dual signal) E: Override operation input (dual signal)

2 Installation and commissioning

2.9.10 Installing the Safety module DSQC1015 for SafeMove

2.9.10 Installing the Safety module DSQC1015 for SafeMove

General

To use the options SafeMove Basic and SafeMove Pro you need to install the Safety module DSQC1015 in the robot controller.

The procedure below describes how to install the Safety module and how to connect the cables. There are different sets of harnesses depending on if SafeMove is used with a software switch or a hardware switch.



Note

It is not possible to have the options SafeMove Basic or SafeMove Pro installed at the same time as Electronic Position Switches or first generation SafeMove.

Location

The Safety module DSQC1015 is a PCIe board that is located inside the IRC5 main computer unit.

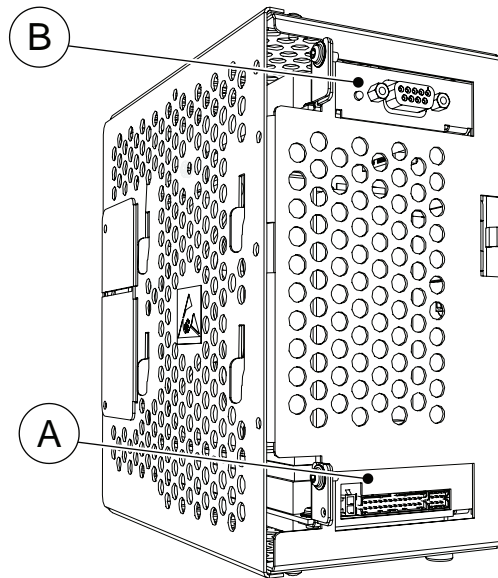

xx1500001760

A	Safety module DSQC1015
B	PCIexpress slot for other devices.



Note

Any PCIe board will fit in any of the PCIe slots. However, to minimize temperature sensitivity, place the Safety module in the lower PCIe slot. If there already is another unit (for example a fieldbus board) in the lower PCIe slot, it is recommended to move this to the upper PCIe slot.

Continues on next page

Required equipment

Illustrations of the cable harnesses are found in sections:

- [Connecting the cables to the Safety module \(software switch and 731-1\) on page 171](#)
- [Connecting the cables to the Safety module \(software switch and 731-2\) on page 173](#)
- [Connecting the cables to the Safety module \(hardware switch and 731-1\) on page 175](#)
- [Connecting the cables to the Safety module \(hardware switch and 731-2\) on page 177](#)

Item	Equipment	Note
	DSQC1015 Safety module	3HAC048858-001
A	Harness safety keyless	3HAC056648-001 Used when the controller has software switch.
A2	Harness safety hard Key switch	3HAC057150-001 Used when the controller has hardware switch.
D	Harness 24 V I/O DSQC1015	3HAC055633-001
B	Harness auxiliary contact	3HAC055642-001
E	Harness internal customer connection	3HAC056638-001 Used when the controller has the option 731-1 <i>Safety internal connection</i> .
F	Harness external customer connection	3HAC056622-001 Used when the controller has the option 731-2 <i>Safety external connection</i> .
C	Harness control panel emergency stop	3HAC056527-001 Used when the controller has the option 731-2 <i>Safety external connection</i> .
G	Harness extended Key switch	3HAC023476-001 Used when the controller has the option 735-3 or 735-4 <i>Additional contacts</i> .
	Standard toolkit	The contents are defined in section Standard toolkit.
	Circuit diagram	See Circuit diagrams on page 349 .

Installing the Safety module





	Action	Note/Illustration
1	 DANGER Before doing any work inside the cabinet, disconnect the mains power. For more information, see Electrical safety on page 37 .	

Continues on next page

2 Installation and commissioning

2.9.10 Installing the Safety module DSQC1015 for SafeMove

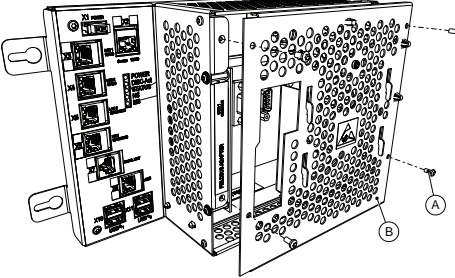
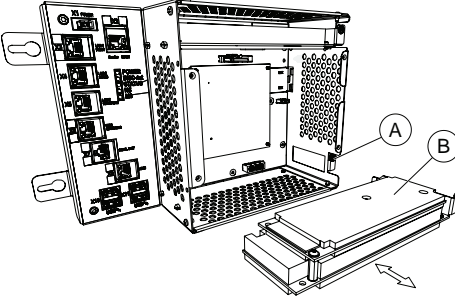
Continued

	Action	Note/Illustration
2	<p> ELECTROSTATIC DISCHARGE (ESD)</p> <p>The unit is sensitive to ESD. Before handling the unit please observe the safety information in section <i>The unit is sensitive to ESD on page 49</i></p>	
3	<p>Open the computer unit by removing the attachment screws and lift off the cover. Disconnect the fan connector.</p> <p> CAUTION</p> <p>Be careful with the fan cable when opening and removing the upper cover. The fan cable must not be stretched.</p>	 <p>xx130000684</p> <p>A Attachment screws (4 pcs.) B Cover</p>
4	<p>Remove the attachment screw on top of the slot bracket.</p>	
5	<p>Fit the Safety module in position by pushing it into the socket on the motherboard.</p>	 <p>xx1500001761</p> <p>A Attachment screw B Safety module</p> <p> CAUTION</p> <p>Always grip the board around the edges to avoid damage to the board or its components.</p>
6	<p>Refit the attachment screw on top of the Safety module bracket.</p>	

Continues on next page

2 Installation and commissioning

2.9.10 Installing the Safety module DSQC1015 for SafeMove

Continued

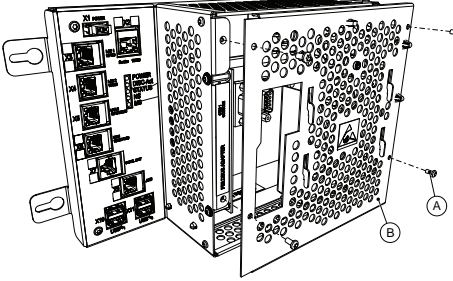

	Action	Note/Illustration
7	Refit the fan connector and close the computer unit.  CAUTION Be careful with the fan cable when closing the cover. The fan cable must not be squeezed.	 xx130000684 A Attachment screws (4 pcs.) B Cover
8	Connect all cables according to the procedures described below.	

Connecting the cables to the Safety module (software switch and 731-1)

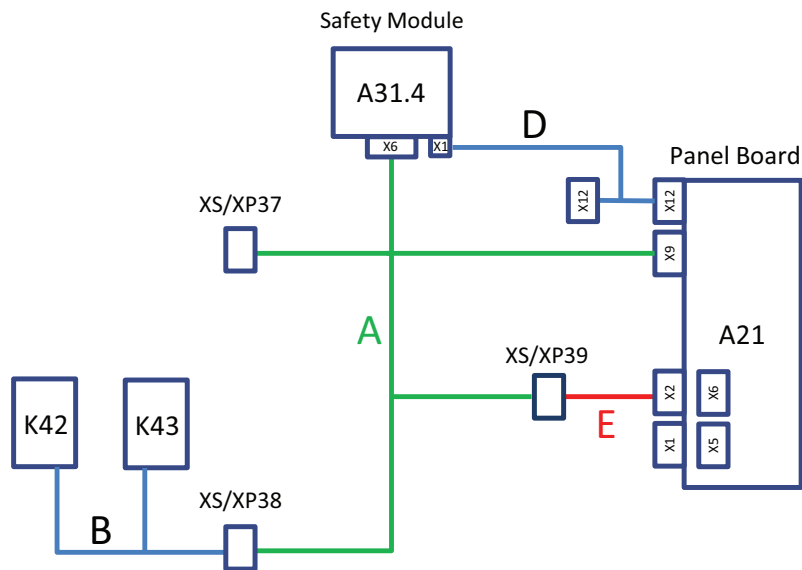
This procedure describes how to connect the cables for a robot controller equipped with the options *Software switch* and *731-1 Safety internal connection*.



xx1500003028

	Action	Note/Illustration
1	 DANGER Before doing any work inside the cabinet, disconnect the mains power. For more information, see Electrical safety on page 37 .	
2	 WARNING The unit is sensitive to ESD. Before handling the unit, see The unit is sensitive to ESD on page 49 .	

Continues on next page

2 Installation and commissioning

2.9.10 Installing the Safety module DSQC1015 for SafeMove

Continued

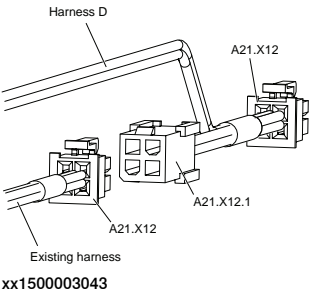
	Action	Note/Illustration
3	Dismantle mode switch, emergency stop button, motor on button, and plug the holes on the front panel.	
4	Disconnect connector A21.X9 from the panel board, and remove the harness.	
5	Connect connector A21.X9 on safety keyless harness (A) to panel board.	
6	Mount auxiliary contact harness contact blocks (B) on contactors K42 and K43.	
7	Connect auxiliary contact harness (B) to safety keyless harness (A) at connector XS/XP38.	
8	Connect safety keyless harness connector A31.4.X6 (A) to Safety module DSQC1015.	
9	Connect connector A31.4.X1 on 24 V I/O harness (D) to Safety module DSQC1015.	 CAUTION Do not connect an external power source.
10	Disconnect existing connector A21.X12 from the panel board, and connect to connector A21.X12.1 on 24 V I/O harness (D).	
11	Connect connector A21.X12 on 24 V I/O harness (D) to panel board.	
12	Disconnect existing connectors A21.X1, A21.X2, A21.X5 and A21.X6 from the panel board.	
13	Connect connectors from internal customer connection harness (E) to panel board.	
14	Connect safety keyless harness (A) with internal customer connection harness (E) at connector XS/XP39.	
15	Route cables properly in existing cable holders.	



Continues on next page

Connecting the cables to the Safety module (software switch and 731-2)

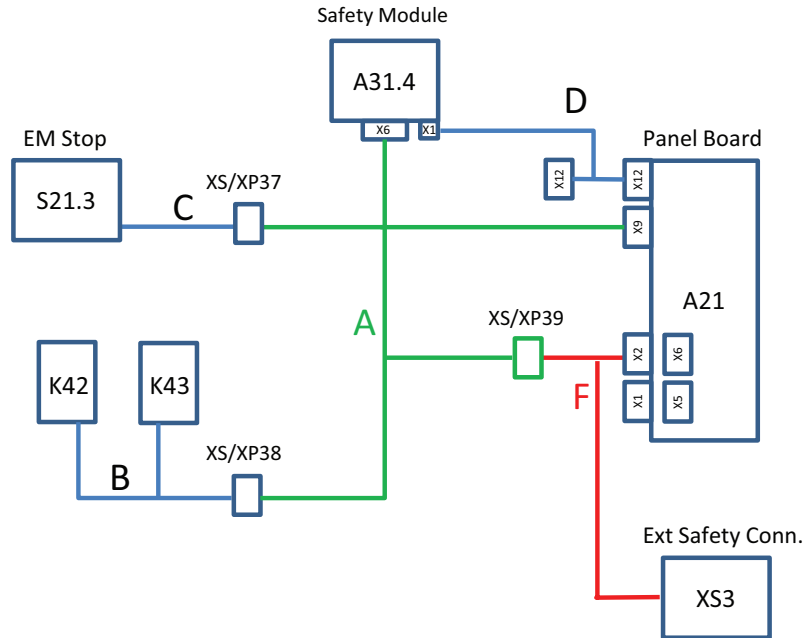
This procedure describes how to connect the cables for a robot controller equipped with the options *Software switch* and *731-2 Safety external connection*.



xx1500003029

	Action	Note/Illustration
1	 DANGER Before doing any work inside the cabinet, disconnect the mains power. For more information, see Electrical safety on page 37 .	
2	 WARNING The unit is sensitive to ESD. Before handling the unit, see The unit is sensitive to ESD on page 49 .	
3	Dismantle mode switch and motor on button, and plug the holes on the front panel.	
4	Remove cabling from the emergency stop button, and replace with emergency Stop harness (C).	Note wire numbers and placement before removal.
5	Disconnect connector A21.X9 from the panel board, and remove the harness.	
6	Connect connector A21.X9 on safety keyless harness (A) to panel board.	
7	Mount auxiliary contact harness contact blocks (B) on contactors K42 and K43.	

Continues on next page

2 Installation and commissioning

2.9.10 Installing the Safety module DSQC1015 for SafeMove

Continued

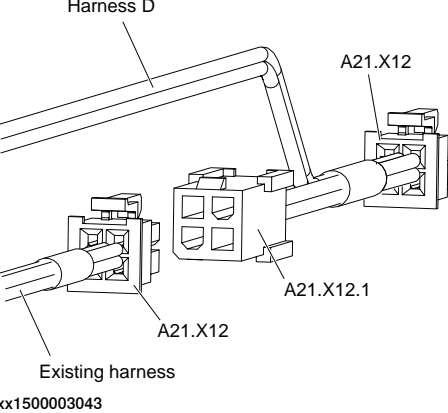
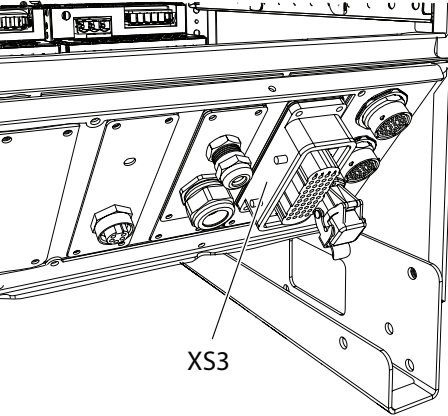
	Action	Note/Illustration
8	Connect auxiliary contact harness (B) to safety keyless harness (A) at connector XS/XP38.	
9	Connect safety keyless harness connector A31.4.X6 (A) to Safety module DSQC1015.	
10	Connect connector A31.4.X1 on 24 V I/O harness (D) to Safety module DSQC1015.	 <p>CAUTION Do not connect an external power source.</p>
11	Disconnect existing connector A21.X12 from the panel board, and connect to connector A21.X12.1 on 24 V I/O harness (D).	 <p>Diagram illustrating the connection of Harness D to connector A21.X12.1 on the panel board. An existing harness is shown disconnected from A21.X12.</p> <p>xx1500003043</p>
12	Connect connector A21.X12 on 24 V I/O harness (D) to panel board.	
13	Disconnect existing connectors A21.X1, A21.X2, A21.X5 and A21.X6 from the panel board.	
14	Connect connectors from external customer connection harness (F) to panel board.	
15	Connect safety keyless harness (A) with external customer connection harness (F) at connector XS/XP39.	
16	Fit connector XS3 in to a free customer connector slot on the connection panel.	 <p>Diagram illustrating the installation of connector XS3 into a free customer connector slot on the connection panel.</p> <p>xx1500003045</p>
17	Route cables properly in existing cable holders.	

Continues on next page

Connecting the cables to the Safety module (hardware switch and 731-1)

This procedure describes how to connect the cables for a robot controller equipped with the options *Hardware switch* and *731-1 Safety internal connection*.



Note

This application requires options 735-3 additional contacts, (3 modes) or option 735-4 additional contacts, (2 modes).

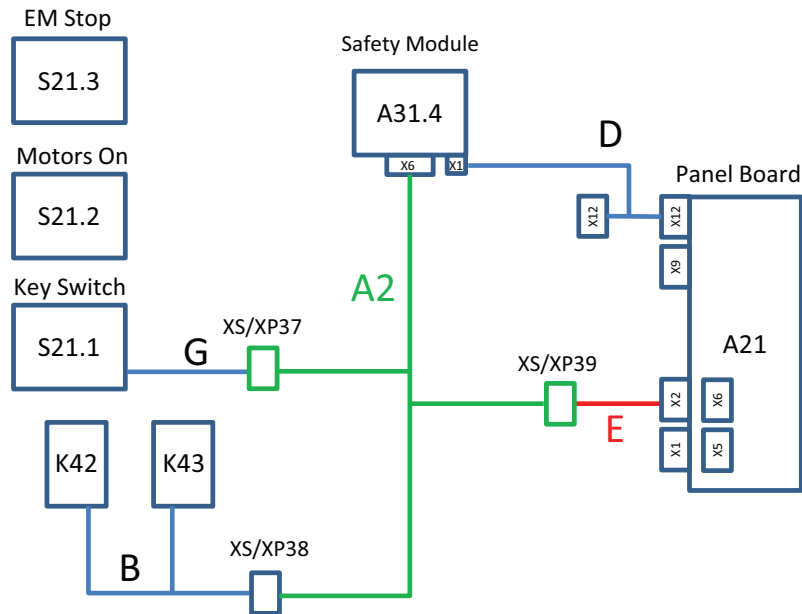

xx1500003030

	Action	Note/Illustration
1	<p>DANGER</p> <p>Before doing any work inside the cabinet, disconnect the mains power. For more information, see Electrical safety on page 37.</p>	
2	<p>WARNING</p> <p>The unit is sensitive to ESD. Before handling the unit, see The unit is sensitive to ESD on page 49.</p>	
3	Mount auxiliary contact harness contact blocks (B) on contactors K42 and K43.	
4	Connect auxiliary contact harness (B) to safety hard Key switch harness (A2) at connector XS/XP38.	
5	Connect safety hard Key switch harness connector A31.4.X6 (A2) to Safety module DSQC1015.	

Continues on next page

2 Installation and commissioning

2.9.10 Installing the Safety module DSQC1015 for SafeMove

Continued

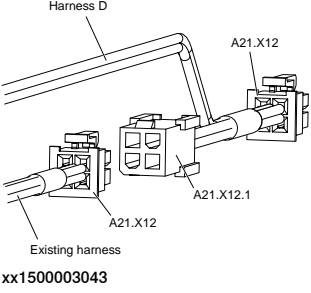
	Action	Note/Illustration
6	Connect connector A31.4.X1 on 24 V I/O harness (D) to Safety module DSQC1015.	 CAUTION Do not connect an external power source.
7	Disconnect existing connector A21.X12 from the panel board, and connect to connector A21.X12.1 on 24 V I/O harness (D).	
8	Connect connector A21.X12 on 24 V I/O harness (D) to panel board.	
9	Disconnect existing connectors A21.X1, A21.X2, A21.X5 and A21.X6 from the panel board.	
10	Connect connectors from internal customer connection harness (E) to panel board.	
11	Connect safety hard Key switch harness (A2) with internal customer connection harness (E) at connector XS/XP39.	
12	Connect extended Key switch harness (G) to safety hard Key switch harness (A2) at connector XS/XP37.	
13	Route cables properly in existing cable holders.	

Continues on next page

Connecting the cables to the Safety module (hardware switch and 731-2)

This procedure describes how to connect the cables for a robot controller equipped with the options *Hardware switch* and *731-2 Safety external connection*.



Note

This application requires options 735-3 additional contacts, (3 modes) or option 735-4 additional contacts, (2 modes).

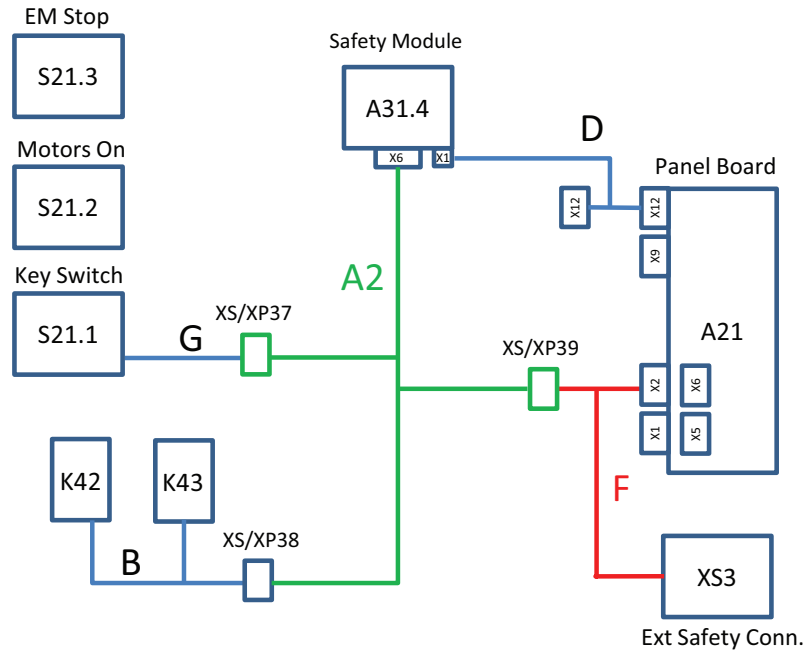

xx1500003031

	Action	Note/Illustration
1	<p>DANGER</p> <p>Before doing any work inside the cabinet, disconnect the mains power. For more information, see Electrical safety on page 37.</p>	
2	<p>WARNING</p> <p>The unit is sensitive to ESD. Before handling the unit, see The unit is sensitive to ESD on page 49.</p>	
3	Mount auxiliary contact harness contact blocks (B) on contactors K42 and K43.	
4	Connect auxiliary contact harness (B) to safety hard Key switch harness (A2) at connector XS/XP38.	
5	Connect safety hard Key switch harness connector A31.4.X6 (A2) to Safety module DSQC1015.	

Continues on next page

2 Installation and commissioning

2.9.10 Installing the Safety module DSQC1015 for SafeMove

Continued

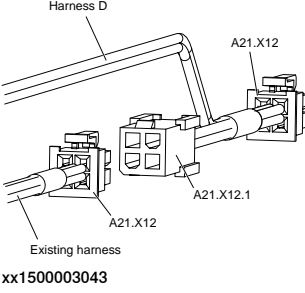
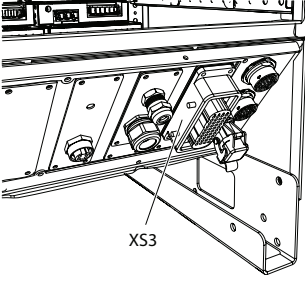
	Action	Note/Illustration
6	Connect connector A31.4.X1 on 24 V I/O harness (D) to Safety module DSQC1015.	 CAUTION Do not connect an external power source.
7	Disconnect existing connector A21.X12 from the panel board, and connect to connector A21.X12.1 on 24 V I/O harness (D).	
8	Connect connector A21.X12 on 24 V I/O harness (D) to panel board.	
9	Disconnect existing connectors A21.X1, A21.X2, A21.X5 and A21.X6 from the panel board.	
10	Connect connectors from external customer connection harness (F) to panel board.	
11	Connect safety hard Key switch harness (A2) with external customer connection harness (F) at connector XS/XP39.	
12	Fit connector XS3 in to a free customer connector slot on the connection panel.	
13	Connect extended Key switch harness (G) to safety hard Key switch harness (A2) at connector XS/XP37.	
14	Route cables properly in existing cable holders.	

2.9.11 Installation of DispensePac support

About DispensePac

To use the DispensePac option you need to connect externally placed Process I/O board(s). The procedure below shows how to connect the DeviceNet cable from the Process I/O board to the DeviceNet signal cable from the Process Interface Board.

Location

The illustration below shows the location of the Process Interface Board and the connection point of the DeviceNet cable(s).

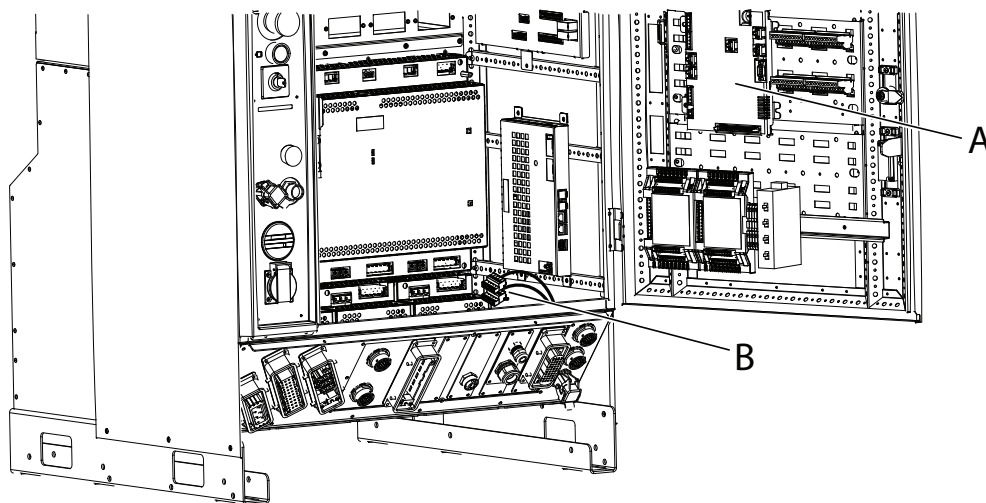

xx0900000130

A	Process Interface Board
B	A57.X1 and A57.X2 DeviceNet connectors

Connecting Process I/O boards

	Action	Note
1	The DeviceNet cable from the Process I/O board (not included in the DispensePac support option) is connected (without termination resistance) to the DeviceNet cable, marked A57.XT1/XT2, from the Process Interface Board.	The connectors A57.XT1 and A57.XT2 are found on the bottom of the Controller cabinet, at the end of the cable from the Process Interface Board.
2	If a second Process I/O board is to be connected, remove the termination resistance on the second cable and connect the second Process I/O board to this cable.	

2 Installation and commissioning

2.9.12 Installation of additional drive units

2.9.12 Installation of additional drive units

General

The following sections describes the standard installation of additional drive units. For more complex configurations please contact ABB.

For information about additional axes, see *Application manual - Additional axes and standalone controller*.

For information about motor units and gear units, see *Product manual - Motor Units and Gear Units*.



Note

Make sure the robot software is configured to reflect the drive functions installed.

Location

The illustration shows the location of drive units in the controller.

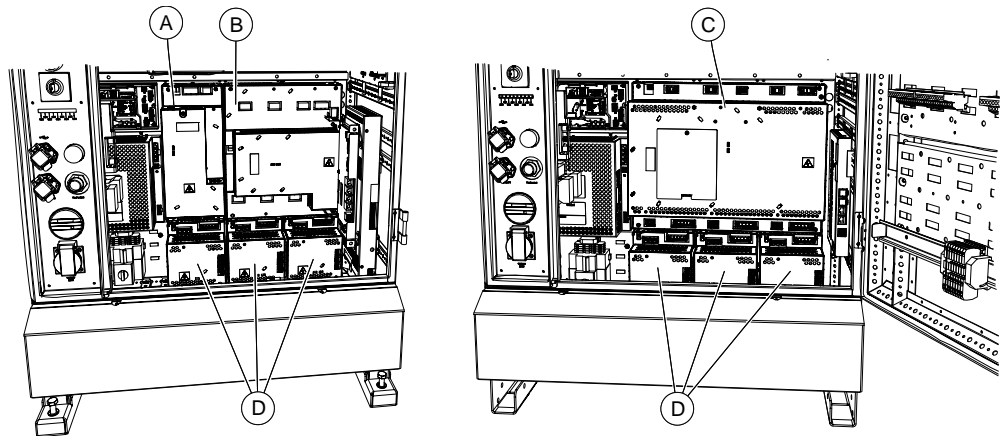

xx1400000484

A	Additional Rectifier Unit (only used for additional axes in combination with small robots)
B	Main Drive Unit for small robots
C	Main Drive Unit for large robots
D	Additional Drive Units (for additional axes)

Configuration

The drive module exists in a number of versions, these are described in section [Configuration of the drive system on page 118](#).

Required equipment

General

Equipment	Note
Drive units	Specified in section Configuration of the drive system on page 118 .

Continues on next page

2 Installation and commissioning

2.9.12 Installation of additional drive units

Continued

Equipment	Note
Standard toolkit	The contents are defined in section Standard toolkit, IRC5 on page 323 .
Circuit diagram	See Circuit diagrams on page 349 .

First additional drive unit, low voltage system

Article number	Equipment	Quantity	Note
3HAC030923-001	DSQC664 HV ADU Drive unit	1	
3HAC035381-001	DSQC 417 LVHC ARU	1	
3HAC036612-001	Harn-ARU/ADU DC-bus	1	
3HAC036680-001	Adapter MDU - ARU	1	
3HAC036686-001	Harn-ARU/MDU 24V	1	
3HAC024254-005	Ethernet cable strait con	1	650 mm
3HAC024254-010	Ethernet cable strait con	1	400 mm
3HAC032595-001	Harn-MDU/ADU 24V	1	
3HAC049514-001 ⁱ	Harn-External axis 7	1	
3HAC049197-001 ^f	Ext.axis brake harness	1	
3HAB9310-2	Gasket	1	
3HAC035583-001	Bleeder 1,8 kW ass.	1	
3HAC036275-001	Bracket bleeder 2	2	
3HAC037758-001	Plug part with marking 2p	1	For bleeder.
3HAC029105-001	Fan	2	Not needed if option 708-2 and/or 764-2 is installed.
3HAC020677-001	Harness axc/XS41	1	This connector is only needed if the external axis uses a separate serial measurement board (SMB) than the manipulator.

ⁱ The old harness 3HAC032591-001 can be used instead of harnesses 3HAC049514-001 and 3HAC049197-001.

Second and third additional drive unit, low voltage system

Article number	Equipment	Quantity	Note
3HAC030923-001	DSQC664 HV ADU Drive unit	1	
3HAC036612-00X	Harn-ARU/ADU DC-bus	1	Different cables depending on the size of the manipulator. See Configuration of the drive system on page 118 .
3HAC032601-001	Harn-ADU 24V	1	
3HAC024254-008	Ethernet cable strait con	1	280 mm
3HAC032592-001	Harn-External axis 8/9	1	

Continues on next page

2 Installation and commissioning

2.9.12 Installation of additional drive units

Continued

First additional drive unit, high voltage system

Article number	Equipment	Quantity	Note
3HAC030923-001	DSQC664 HV ADU Drive unit	1	
3HAC032612-001	Harn-MDU/ADU DC-bus	1	
3HAC032595-001	Harn-MDU/ADU 24V	1	
3HAC024254-007	Ethernet cable strait con	1	1000 mm
3HAC049514-001 ⁱ	Harn-External axis 7	1	
3HAC049197-001 ⁱ	Ext.axis brake harness	1	
3HAB9310-2	Gasket	1	
3HAC029105-001	Fan	1	Not needed if option 708-2 and/or 764-2 is installed.
3HAC020677-001	Harness axc/XS41	1	This connector is only needed if the external axis uses a separate serial measurement board (SMB) than the manipulator.

ⁱ The old harness 3HAC032591-001 can be used instead of harnesses 3HAC049514-001 and 3HAC049197-001.

Second and third additional drive unit, high voltage system

Article number	Equipment	Quantity	Note
3HAC030923-001	DSQC664 HV ADU Drive unit	1	
3HAC032612-001	Harn-MDU/ADU DC-bus	1	
3HAC032601-001	Harn-ADU 24V	1	
3HAC024254-008	Ethernet cable strait con	1	280mm
3HAC032592-001	Harn-External axis 8/9	1	

Installing the first additional drive unit

The procedure below details how to install the first additional drive unit.





	Action	Note/Illustration
1	 DANGER Before doing any work inside the cabinet, disconnect the mains power. For more information, see Electrical safety on page 37 .	

Continues on next page

2 Installation and commissioning

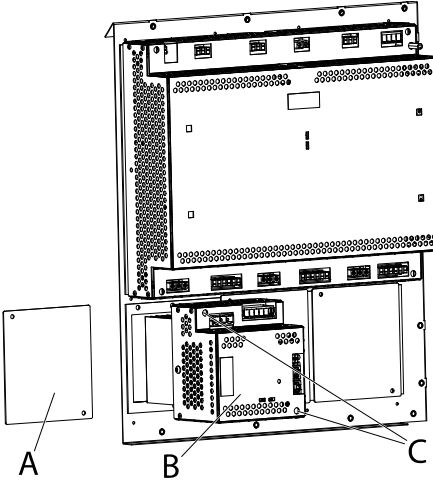
2.9.12 Installation of additional drive units

Continued





	Action	Note/Illustration
2	Install the first additional drive unit in the empty slot to the left.	 <p>xx0900000127</p> <ul style="list-style-type: none"> • A: cover plate • B: Additional Drive Unit • C: attachment screws
3	Install the additional rectifier unit.	 Note Only for small robots with low voltage system.
4	Install the bleeder for the additional rectifier unit. See Replacement of brake resistor bleeder on page 294 .	 Note Only for small robots with low voltage system.
5	Install the additional drive system fans. See Replacement of drive system fans on page 284 .	 Note Only for small robots with low voltage system.
6	Install the XS7 additional axes power connector and gasket to the front panel of the IRC5 controller and connect the ground cable.	
7	Connect the additional axes brake harness ¹ between the contactor board (A43) and the internal signal connector from XS7.	The additional axes brake harness contains signals for external brake release, external brake release push button, and PTC2.
8	Plug in the internal power connector from XS7 to the additional drive unit (A41.3).	

Continues on next page

2 Installation and commissioning

2.9.12 Installation of additional drive units

Continued



	Action	Note/Illustration
9	<p>For small robots with low voltage system:</p> <ul style="list-style-type: none"> • Connect the 24V cable between the main drive unit (A41.1) and the additional rectifier unit (A41.2). • Connect the power cable adapter between the power supply to the main drive unit (A41.1) and the additional rectifier unit (A41.2). • Connect the power cable between the additional rectifier unit (A41.2) and the additional drive unit (A41.3) and connect the ground cable. • Connect the Ethernet cable between the main drive unit (A41.1) and the additional rectifier unit (A41.2). 	 Note Only for small robots with low voltage system.
10	<p>For large robots with high voltage system:</p> <ul style="list-style-type: none"> • Connect the power cable between the main drive unit (A41.1) and the additional drive unit (A41.3) and connect the ground cable. 	 Note Only for large robots with high voltage system.
11	Connect the 24V cable between the main drive unit (A41.1) and the additional drive unit (A41.3).	
12	Connect the Ethernet cable between the main drive unit (A41.1) and the additional drive unit (A41.3).	
13	Install the XS41 additional axes SMB connector to the front panel of the IRC5 controller and plug in the connector to the axis computer (A42).	 Note This connector is only needed if the external axis uses a separate serial measurement board (SMB) than the manipulator.
14	Strap the new cabling together with the existing cabling inside the module.	 ELECTROSTATIC DISCHARGE (ESD) All cables inside the controller must be properly routed and strapped to avoid interference.
15	Make sure the robot software is configured to reflect the drive functions installed.	

ⁱ The old harness 3HAC032591-001 can be used instead of harnesses 3HAC049514-001 and 3HAC049197-001.

Continues on next page

Installing a second and third additional drive unit

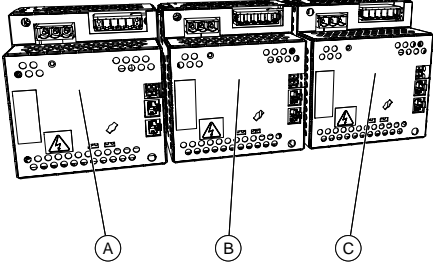
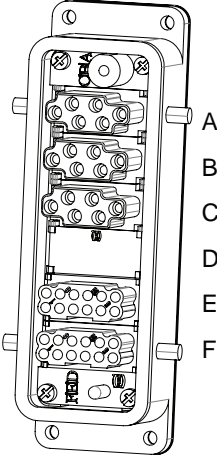
The procedure below details how to install a second and third additional drive unit. A prerequisite is that the first additional drive unit is installed.



	Action	Note/Illustration
1	 <p>DANGER</p> <p>Before doing any work inside the cabinet, disconnect the mains power. For more information, see Electrical safety on page 37.</p>	
2	<p>Install the additional drive units in the IRC5 controller.</p>	 <p>xx140000272</p> <p>A Additional drive unit 1 B Additional drive unit 2 C Additional drive unit 3</p>
3	<p>Install the additional axes power connector modules (B, C) to the XS7 connector on the front panel of the IRC5 controller.</p>	 <p>xx140000273</p> <p>A Additional drive unit 1 B Additional drive unit 2 C Additional drive unit 3 D Empty, not used E Signals F Signals</p>
4	<p>Plug in the internal connectors from XS7 to the additional drive units (A41.4 and A41.5).</p>	
5	<p>Connect the power cables between the additional rectifier unit (A41.2) and the additional drive units (A41.4 and A41.5) and connect the ground cables.</p>	 <p>Note</p> <p>Only for small robots with low voltage system.</p>

Continues on next page

2 Installation and commissioning

2.9.12 Installation of additional drive units

Continued

	Action	Note/Illustration
6	Connect the power cables between the main drive unit (A41.1) and the additional drive units (A41.4 and A41.5) and connect the ground cables.	 Note Only for large robots with high voltage system.
7	Connect the 24V cables between the main drive unit (A41.1) and the additional drive units (A41.4 and A41.5).	
8	Connect the Ethernet cables between the main drive unit (A41.1) and the additional drive units (A41.4 and A41.5).	
9	Install the XS41 additional axes SMB connector to the front panel of the IRC5 controller and plug in the connector to the axis computer (A42).	 Note This connector is only needed if the external axis uses a separate serial measurement board (SMB) than the manipulator.
10	Strap the new cabling together with the existing cabling inside the module.	 ELECTROSTATIC DISCHARGE (ESD) All cables inside the controller must be properly routed and strapped to avoid interference.
11	Make sure the robot software is configured to reflect the drive functions installed.	

2.9.13 Installation of additional Drive Module

General

To be able to use a MultiMove system or to control more than 3 additional axes, an additional Drive Module is needed. The IRC5 Controller is prepared for up to three additional Drive Modules.

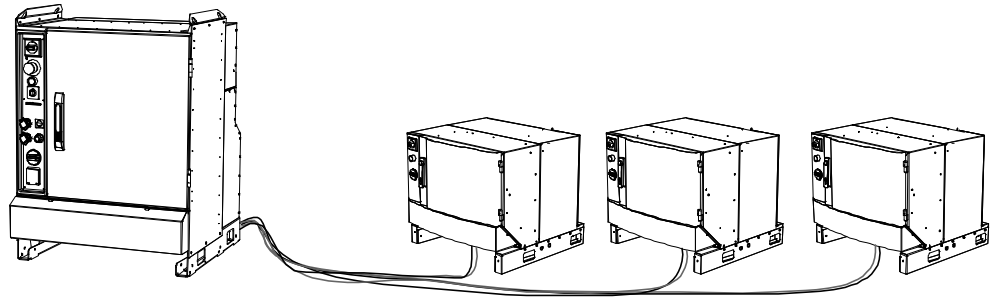

xx0400001042

For more information about installing additional Drive Modules, see *Application manual - MultiMove*. For more information about stacking modules and process modules, see *Product specification - Controller IRC5*.

2 Installation and commissioning

2.9.14 Process module

2.9.14 Process module

About the process module

As an option an empty process module can be purchased, to use for custom equipment. There is one small and one large variant of the process module. An installation kit is available to provide easy mounting of equipment inside the process module.

Option numbers

Product	Option number
Process module, Small	768-1
Process module, Large	768-2
Installation kit	715-1

Measurements

Small process module

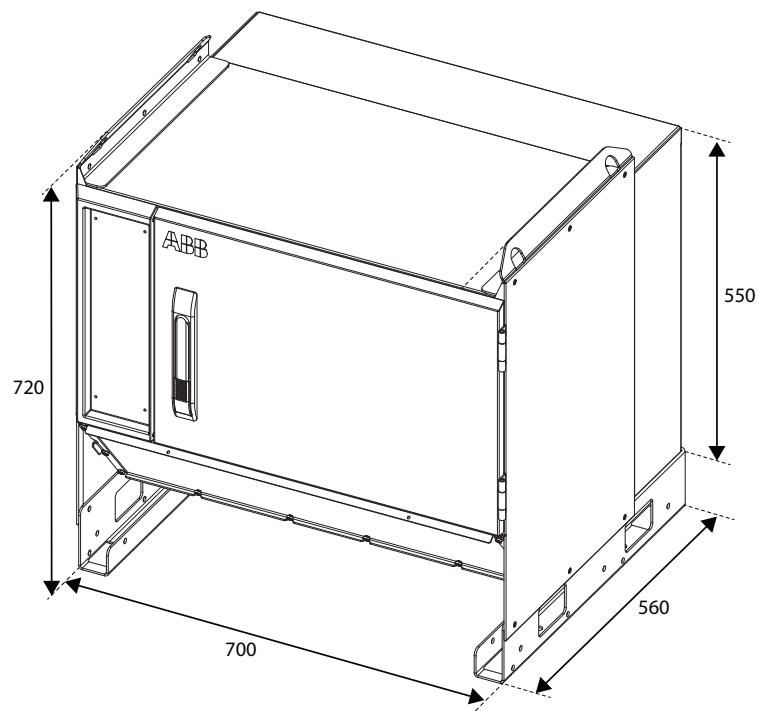

xx1500000116

Continues on next page

Large process module

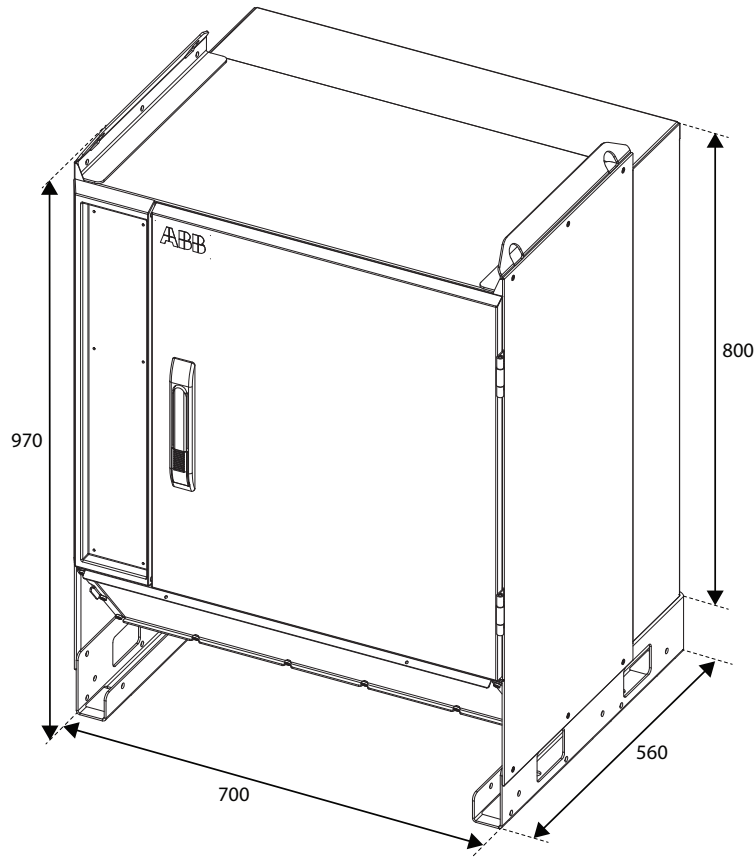

xx150000117

Installation kit

The installation kit can be used for both the small and the large process module. It consists of the following parts.

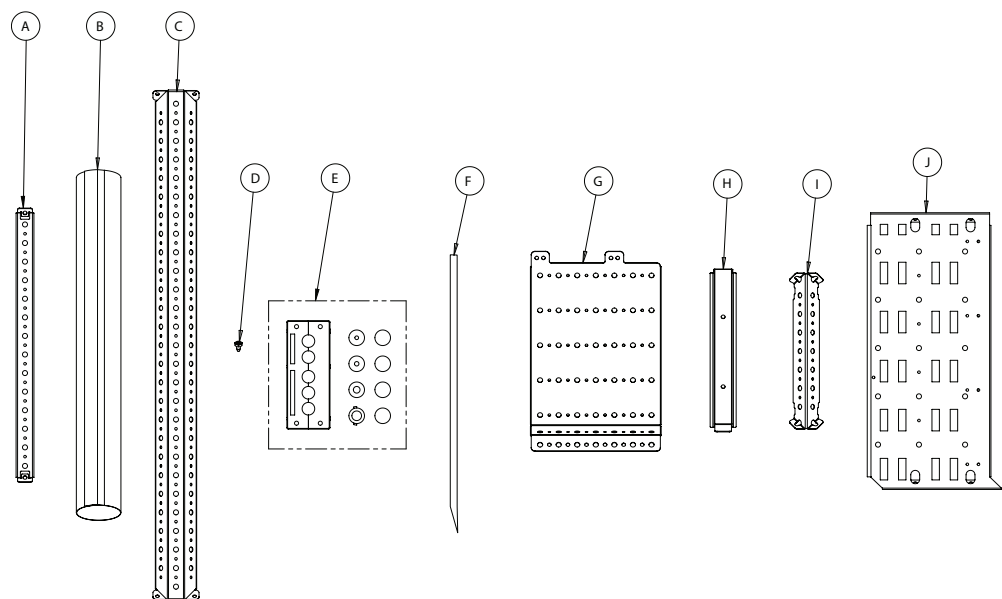

xx150000118

Continues on next page

2 Installation and commissioning

2.9.14 Process module

Continued

A	Mounting bracket (10 pcs)
B	Cable protection
C	Mounting beam (2 pcs)
D	Fastite screw (54 pcs)
E	Cable inlet
F	Velcro with a eyelet (2 pcs)
G	I/O mounting plate
H	Terminal rail
I	Mounting bracket, short (3 pcs)
J	Connection block bracket

Example of process module interior

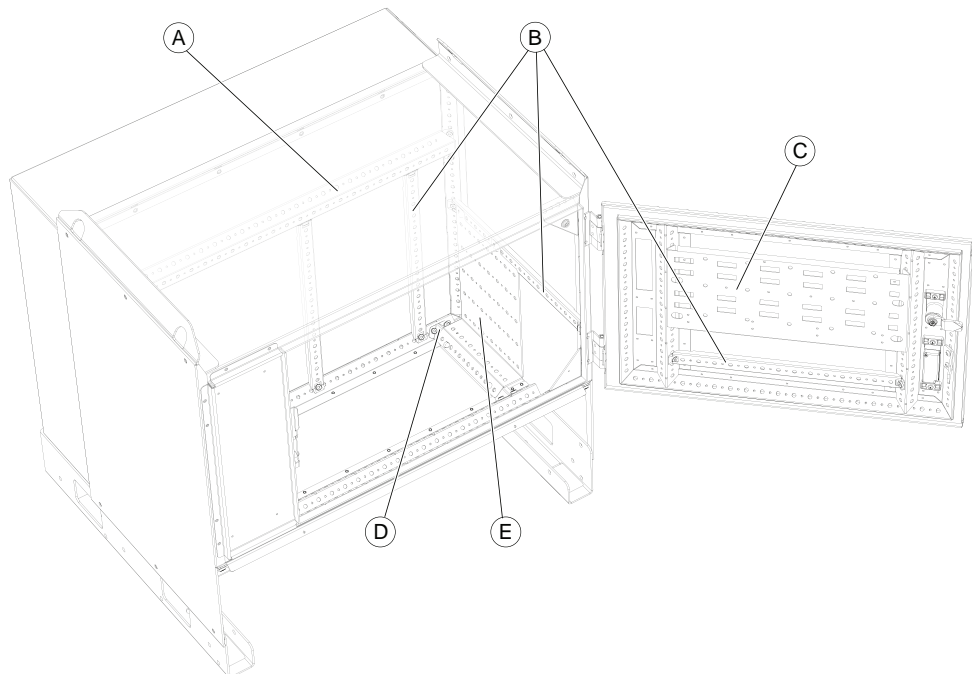

xx150000115

A	Mounting beam
B	Mounting bracket
C	Connection block bracket
D	Mounting bracket, short
E	I/O mounting plate

2.9.15 Installation of drive system fans with temperature sensors

Location

The illustration below shows the location of the drive system fan unit in the controller.

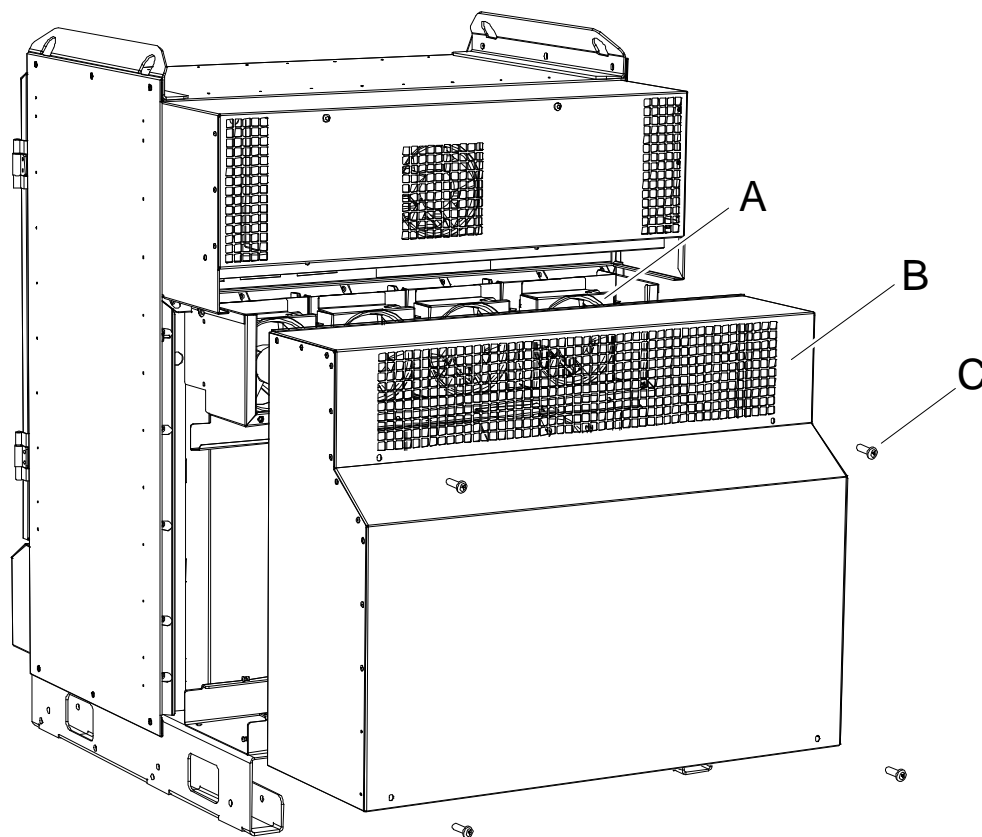

xx0500002011

A	Drive system fan (up to 4 pcs)
B	Cover
C	Attachment screw (4 pcs)

Required equipment

Equipment	Note
<p>The retrofit set includes the following for each fan:</p> <ul style="list-style-type: none"> • Grommet • Fan holder • Fan • Temp sensor with sensor bracket • Gasket (4 pcs) 	<p>Retrofit set Temp Sensor Fan:</p> <ul style="list-style-type: none"> 3HAC056513-001, one fan 3HAC056513-002, two fans 3HAC056513-003, three fans 3HAC056513-004, four fans
Standard toolkit	The contents are defined in section Standard toolkit.

Continues on next page

2 Installation and commissioning

2.9.15 Installation of drive system fans with temperature sensors

Continued

Equipment	Note
Other tools and procedures may be required. See references to these procedures in the step-by-step instructions below.	These procedures include references to the tools required.
Circuit diagram	See Circuit diagrams on page 349 .

Removing the system fan

If a system fan is used, it should be removed when installing sensor controlled drive system fans.

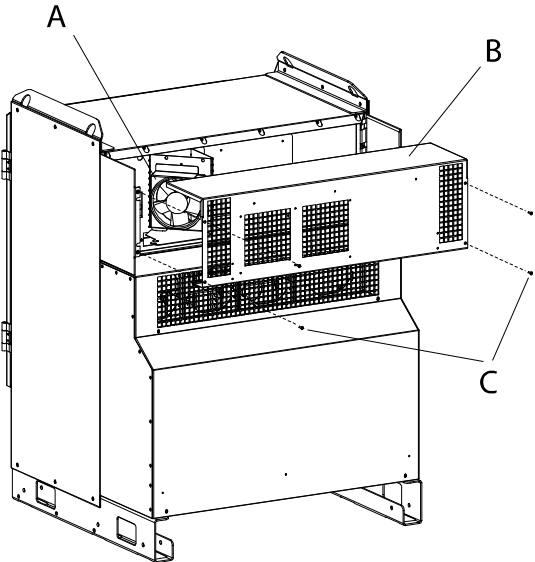
Action	Note/Illustration
<p>1</p>  <p>DANGER</p> <p>Before doing any work inside the cabinet, disconnect the mains power. For more information, see Electrical safety on page 37.</p>	
<p>2</p> <p>Remove the attachment screws on the top cover.</p>	 <p>xx0700000416</p> <p>A Fan B Top cover C Attachment screws (4 pcs)</p>
<p>3</p> <p>Remove the top cover.</p>	
<p>4</p> <p>Disconnect the connector to the fan.</p>	
<p>5</p> <p>Remove the screw (item B in image below).</p>	

Continues on next page

2 Installation and commissioning

2.9.15 Installation of drive system fans with temperature sensors

Continued

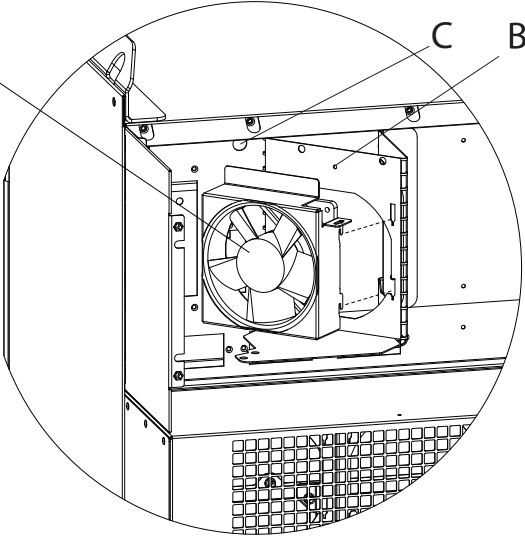
	Action	Note/Illustration
6	Push the fan upwards, and pull it out.	 <p>xx0700000417</p> <p>A Fan B Screw C Cable gland</p>
7	Remove the cable and replace the cable gland with the grommet.	

Removing the old drive system fan

	Action	Note /illustration
1	 <p>DANGER</p> <p>Before doing any work inside the cabinet, disconnect the mains power. For more information, see Electrical safety on page 37.</p>	
2	Remove the moist dust filter magazine. (Option)	How to remove the moist dust filter magazine is detailed in section Replacement of moist dust filter on page 205 .
3	Loosen the four attachment screws to the cover.	
4	Remove the cover.	
5	Disconnect the connector to the fan.	

Continues on next page

2 Installation and commissioning

2.9.15 Installation of drive system fans with temperature sensors

Continued

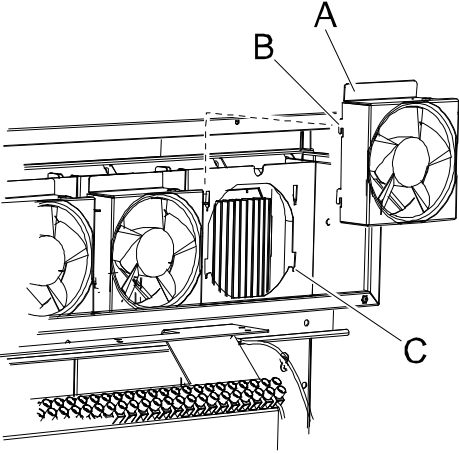
	Action	Note /illustration
6	Push the fan upwards and remove it.	 <p data-bbox="949 779 1050 795">xx0500002015</p> <ul style="list-style-type: none"> <li data-bbox="975 808 1054 835">A Fan <li data-bbox="975 842 1102 869">B Latches <li data-bbox="975 875 1110 902">C Grooves

Assemble the sensor controlled fan

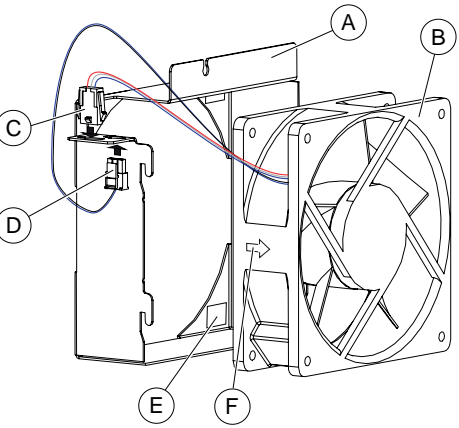
	Action	Note/illustration
1	Fit the gaskets in all the four corners on the inside of the fan holder.	 <p data-bbox="949 1482 1050 1498">xx1500001754</p> <ul style="list-style-type: none"> <li data-bbox="975 1512 1134 1538">A Fan holder <li data-bbox="975 1545 1054 1572">B Fan <li data-bbox="975 1579 1286 1606">C Power supply connector <li data-bbox="975 1612 1214 1639">D Sensor connector <li data-bbox="975 1646 1174 1673">E Gasket (4 pcs) <li data-bbox="975 1680 1342 1706">F Indication of air flow direction
2	Fit the fan in the fan holder. Look at the indication of air flow direction to make sure the fan is inserted the correct way.	
3	Fit the connector for fan power supply from above into the outer hole on the bracket of the fan holder.	

Continues on next page

2 Installation and commissioning

2.9.15 Installation of drive system fans with temperature sensors

Continued

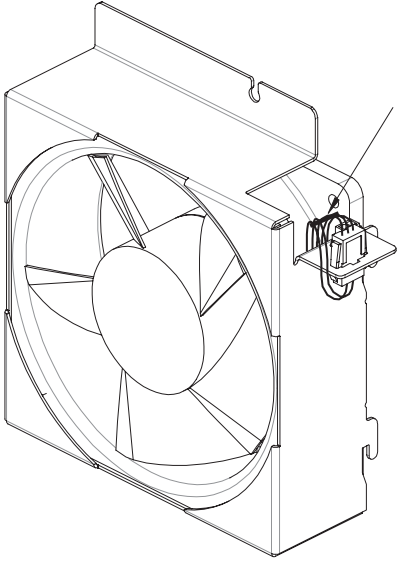
	Action	Note/illustration
4	Strap the wires from the sensor together with the other wires from the fan to avoid the sensor wires to be damaged by sharp edges.	 <p data-bbox="970 878 1082 900">xx1700001154</p>
5	Fit the sensor connector from below into the inner hole on the bracket of the fan holder.	

Fitting the drive system fan with temp sensor

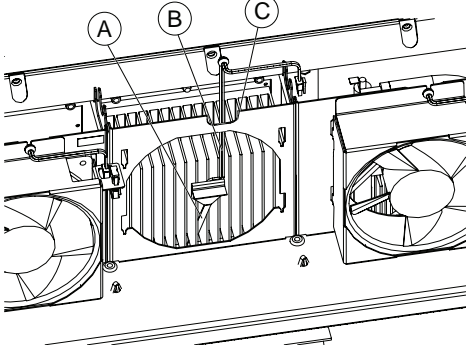
	Action	Note/illustration
1	 <p data-bbox="596 1178 705 1209">DANGER</p> <p data-bbox="504 1236 959 1346">Before doing any work inside the cabinet, disconnect the mains power. For more information, see Electrical safety on page 37.</p>	
2	Insert the sensor between the heat sink fins in the middle.	 <p data-bbox="970 1742 1082 1765">xx1500000858</p> <p data-bbox="1007 1774 1321 1863"> A Sensor on sensor holder B Sensor cable C Fan channel bracket </p>
3	Route the fan cable behind the fan channel bracket.	

Continues on next page

2 Installation and commissioning

2.9.15 Installation of drive system fans with temperature sensors

Continued

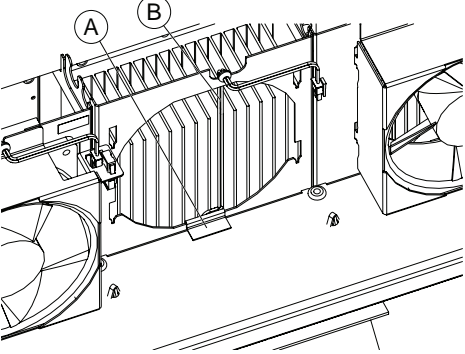
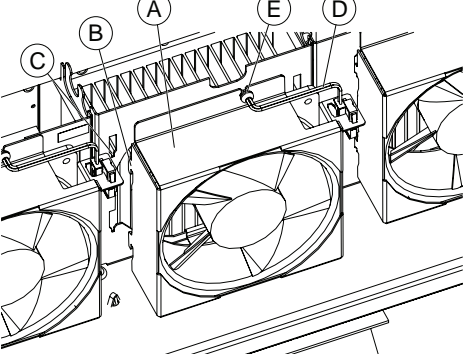
	Action	Note/illustration
4	Fit the sensor holder on the edge of the fan channel bracket.	 <p>xx1500000857</p> <p>A Sensor holder B Sensor cable</p>
5	Fit the fan by placing the latches in the back of the fan housing into the grooves and press the fan down.	 <p>xx1500000856</p> <p>A Fan B Latches C Grooves D Temp sensor cable E Cable gland</p>
6	Slide the cable gland into the indentation in the fan housing. Gently pull the cable so there is no slack on the cable between the sensor and the cable gland.	
7	Connect the connectors to the fan.	
8	Refit the cover and the attachment screws.	
9	Refit the moist dust filter magazine. (Option)	

2.9.16 Installation of the mains connection cable

Location

The illustration shows the location of the incoming mains cable gland connection in the controller.

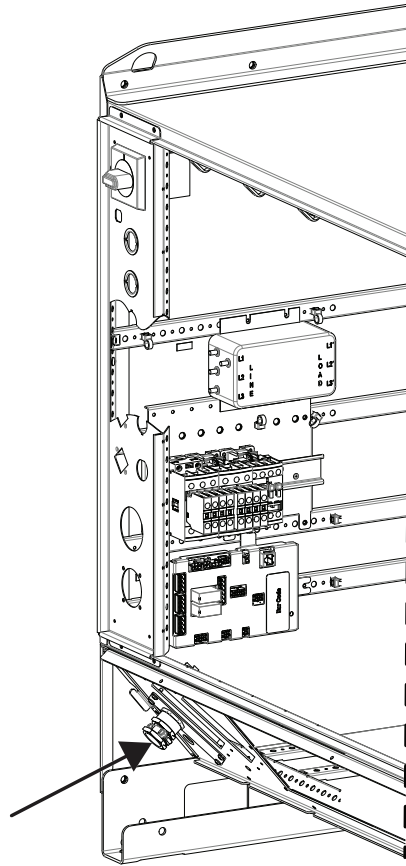

xx2300002063

Required tools and equipment

Equipment	Note
Standard toolkit	Content is defined in section Standard toolkit, IRC5 on page 323 .
Pozidrive M3.5 Form 2	
ESD protective wrist band	

Required documents

Document	Note
Circuit diagram - IRC5	

Continues on next page



2 Installation and commissioning

2.9.16 Installation of the mains connection cable

Continued

Installing the mains connections cable

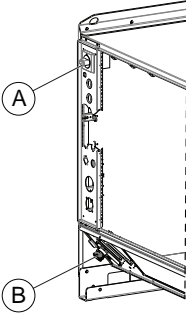
The following procedures detail how to connect incoming mains to the controller through a cable gland.

	Action	Note/illustration
1	Remove the dust protection lid from the cable gland.	 <p>xx2300002064</p> <p>A Incoming mains switch B Cable gland</p>
2	Remove the main switch from the holder.	
3	Remove protection from the incoming mains switch.	
4	Connect incoming mains from an external earth fault protection.	
5	Fit the cable trough the cable gland and tighten.	
6	Strip the insulation on the mains cable long enough to reach the incoming mains switch.	
7	Connect protective earth.	 Note Use cable lugs in the connection. Tightening torque: 5 Nm
8	Route the phase wires through the pipe up to the incoming mains switch.	
9	Strip the phase wires 9-10 mm.  Note 0.35-0.39 mm ² , 18 AWG	
10	Connect the wires to the incoming mains switch.	See circuit diagram. Tightening torque: 0.8 Nm

Continues on next page

2 Installation and commissioning

2.9.16 Installation of the mains connection cable

Continued

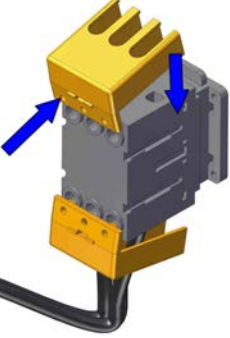
	Action	Note/illustration
11	Refit protection on the incoming mains switch.	 xx2400001854
12	Install the main switch behind the rotary switch.	

2 Installation and commissioning

2.10 Testing

2.10 Testing

Function tests

When the installation is complete, perform the function tests in section [Function tests on page 213](#) to verify that the safety features work properly.

3 Maintenance

3.1 Maintenance schedule for the IRC5 controller

General

The controller must be maintained at regular intervals to ensure its function. The activities and intervals are described in this section.

Intervals

Equipment	Maintenance activity	Interval	Detailed in section:
Complete controller modules	Inspection	12 months ⁱ	Inspection of the controller on page 203.
Moist dust filter	Cleaning		Cleaning moist dust filter on page 209
Moist dust filter	Replacement	24 months ⁱ	Replacement of moist dust filter on page 205
Heat exchanger fan	Inspection	6 months ⁱ	Inspection of the controller on page 203.
Heat exchanger fan	Cleaning	12 months ⁱ	Cleaning of the controller cabinet on page 208.
FlexPendant	Cleaning	When needed	Cleaning the FlexPendant on page 211.
Earth fault breaker F4 (tested if used)	Function test	6 months	Function test of earth fault breaker F4 on page 213
Emergency stop (operating panel)	Function test	12 months	Function test of emergency stop on page 214
Emergency stop (FlexPendant)	Function test	12 months	Function test of emergency stop on page 214
Mode switch	Function test	12 months	Function test of mode switch on page 215
Enabling device	Function test	12 months	Function test of three-position enabling device on page 216
Motor contactors K42, K43	Function test	12 months	Function test of motor contactors K42 and K43 on page 217
Brake contactor K44	Function test	12 months	Function test of brake contactor K44 on page 218
Auto stop (tested if used)	Function test	12 months	Function test of Automatic Stop on page 219
General stop (tested if used)	Function test	12 months	Function test of General Stop on page 220
Superior stop (tested if used)	Function test	12 months	Function test of superior stop on page 221
Limit switch (tested if used)	Function test	12 months	Function test of limit switch on page 222
Automatic fuse F1	Function test	12 months	Function test of automatic fuse F1 on page 223

Continues on next page

3 Maintenance

3.1 Maintenance schedule for the IRC5 controller

Continued

Equipment	Maintenance activity	Interval	Detailed in section:
Reduced speed control	Function test	During commissioning	Function test of reduced speed control on page 224.

ⁱ The interval depends on the working environment of the equipment: a cleaner environment may extend the maintenance interval and vice versa.

Function test after replacement of component

In addition to performing the function tests according to the intervals, function tests should be performed after replacing a component in the controller.

3.2 Inspection activities

3.2.1 Inspection of the controller

Inspection

The procedure below describes how to inspect the IRC5 controller.



WARNING

Please observe the following before commencing any repair work on the IRC5 controller, or units connected to the controller:

- Switch off all electric power supplies with the power switch!
- Before handling, make sure you are grounded through a special ESD wrist bracelet or similar. Many components inside the module are sensitive to ESD (ElectroStatic Discharge) and can be destroyed if exposed to discharge. See the Safety chapter, *The unit is sensitive to ESD on page 49*

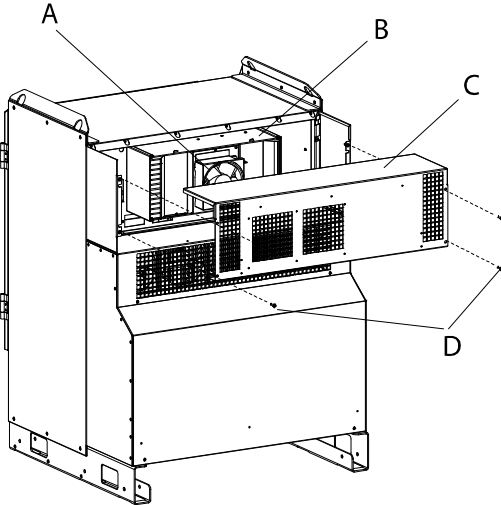
	Action	Note/Illustration
1	Inspect all sealing joints and cable glands to make sure they are airtight in order to prevent dust and dirt from penetrating into the controller cabinet.	
2	Inspect connectors and cabling to make sure they are securely fastened and cabling not damaged.	
3	Inspect the heat exchanger and the fan on the controller to make sure it is clean.	 <p data-bbox="938 1697 1045 1720">xx0500001952</p> <p data-bbox="938 1736 1005 1765">Parts:</p> <ul style="list-style-type: none"> • A: fan • B: heat exchanger • C: top cover • D: attachment screw (4 pcs)

Continues on next page

3 Maintenance

3.2.1 Inspection of the controller

Continued

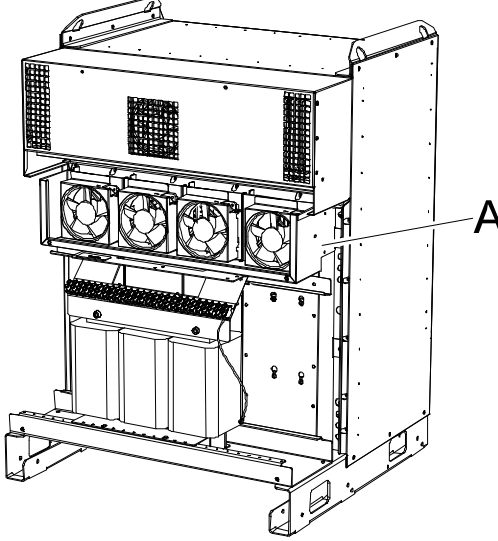
	Action	Note/Illustration
4	Inspect the drive system fans and air channels in the controller to make sure they are clean.	 <p>xx0500002172</p> <ul style="list-style-type: none">• A: drive system fans (4 pcs)
5	After cleaning: <ul style="list-style-type: none">• Temporarily turn the power supply to the modules on.• Inspect all fans to make sure they function correctly.• Turn the power supply back off.	
6	Replace any malfunctioning fans as described in Replacement of heat exchange unit and fan on page 236 .	

3.3 Changing/replacing activities

3.3.1 Replacement of moist dust filter

Location

The moist dust filters are located as shown in the illustration below.

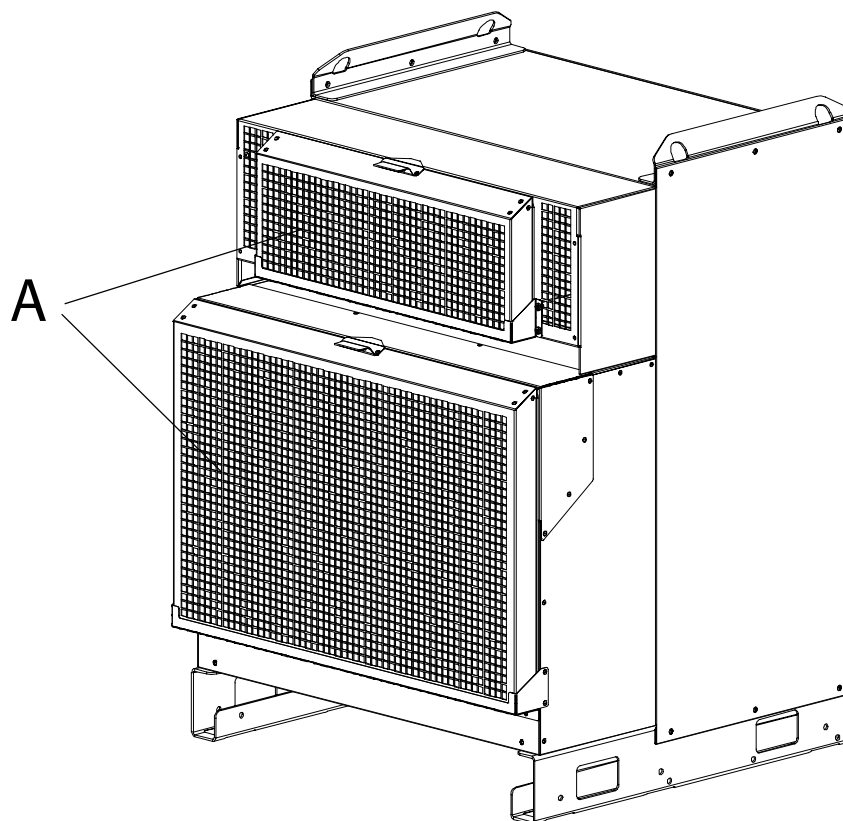

xx130000852

A	Moist dust filter magazine
---	----------------------------

Required equipment

Equipment	Note
Moist dust filter	
Other tools and procedures may be required. See references to these procedures in the step-by-step instructions below.	These procedures include references to the tools required.

Continues on next page

3 Maintenance

3.3.1 Replacement of moist dust filter

Continued

Removal

The procedure below details how to replace the moist dust filter.

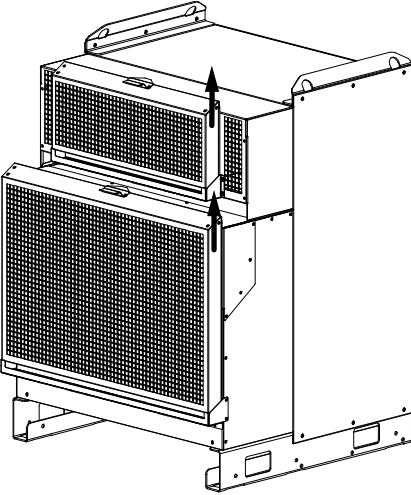
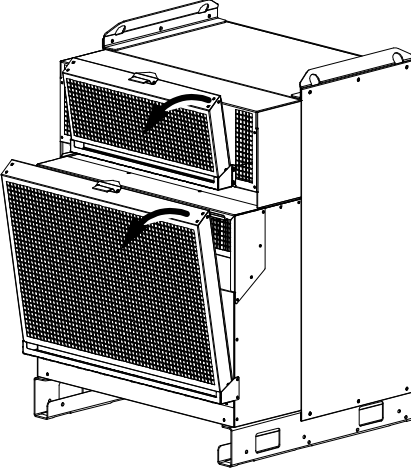
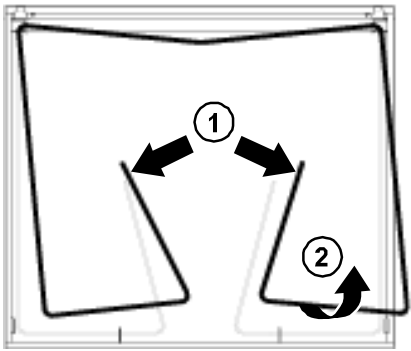
	Action	Note/Illustration
1	Pull the moist dust filter magazine upwards.	 <p>xx0700000131</p>
2	Pull the moist dust filter magazine in the arrow direction and remove it.	 <p>xx0700000132</p>
3	Remove the old moist dust filter by releasing the lock shackle and lifting it.	 <p>xx0200000003</p>

Continues on next page

Refitting

The procedure below details how to refit the moist dust filter.

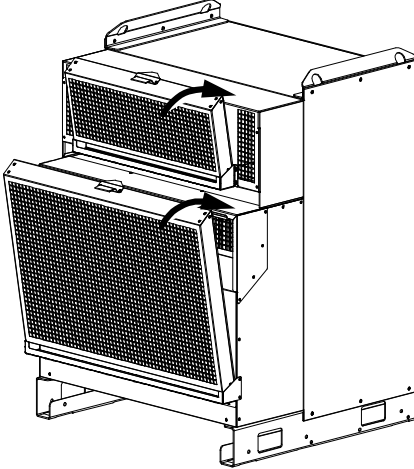
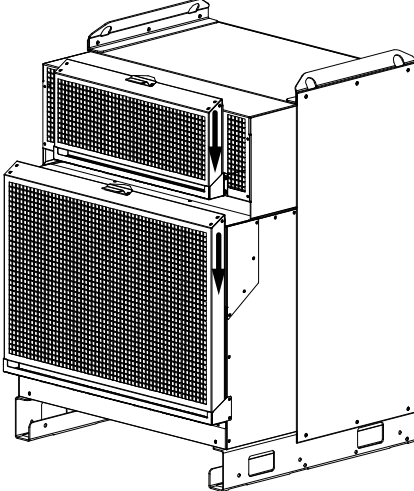
	Action	Note/Illustration
1	<p>Fit the new moist dust filter in the magazine and lock it with the lock shackle.</p> <p> Note</p> <p>The compact surface on the moist dust filter must be turned inwards to the cabinet.</p>	
2	<p>Fit the moist dust filter magazine on the cabinet and push inwards.</p>	 <p>xx0700000134</p>
3	<p>Push the moist dust filter magazine downwards until it stops.</p>	 <p>xx0700000135</p>

3 Maintenance

3.4.1 Cleaning of the controller cabinet

3.4 Cleaning activities

3.4.1 Cleaning of the controller cabinet

Required equipment

Equipment, etc.	Note
Vacuum cleaner	ESD protected
Cleaning agent, exterior cleaning	If necessary, use a lint-free cloth with, for example, alcohol

Internal cleaning

	Action	Note/Illustration
1	Clean the cabinet interior with a vacuum cleaner if necessary.	
2	The control module is equipped with a heat exchanger, it is important that it is clean. The heat exchanger is located on the rear of the controller.	If required, remove any heat exchangers before cleaning as detailed in the section, Replacement of heat exchange unit and fan on page 236 .
3	Remove the drive module fans and use compressed air to clean: <ul style="list-style-type: none">• the fans• the air channels• the drive unit heat sinks.	How to remove the fans is detailed in section, Replacement of drive system fans on page 284 .

Cleaning considerations

This section specifies some special considerations when cleaning the controller.

- Always use ESD protection.
- Always use cleaning equipment as specified above. Any other cleaning equipment may shorten the life of paint work, rust inhibitors, signs, or labels.
- Always make sure that all protective covers are fitted to the controller before cleaning.
- Never remove any covers or other protective devices when cleaning the outside of the controller.
- Never use compressed air or spray with a high pressure cleaner.
- Never leave the door open when cleaning the exterior.

3.4.2 Cleaning moist dust filter

Location

The moist dust filters are located as shown in the illustration below.

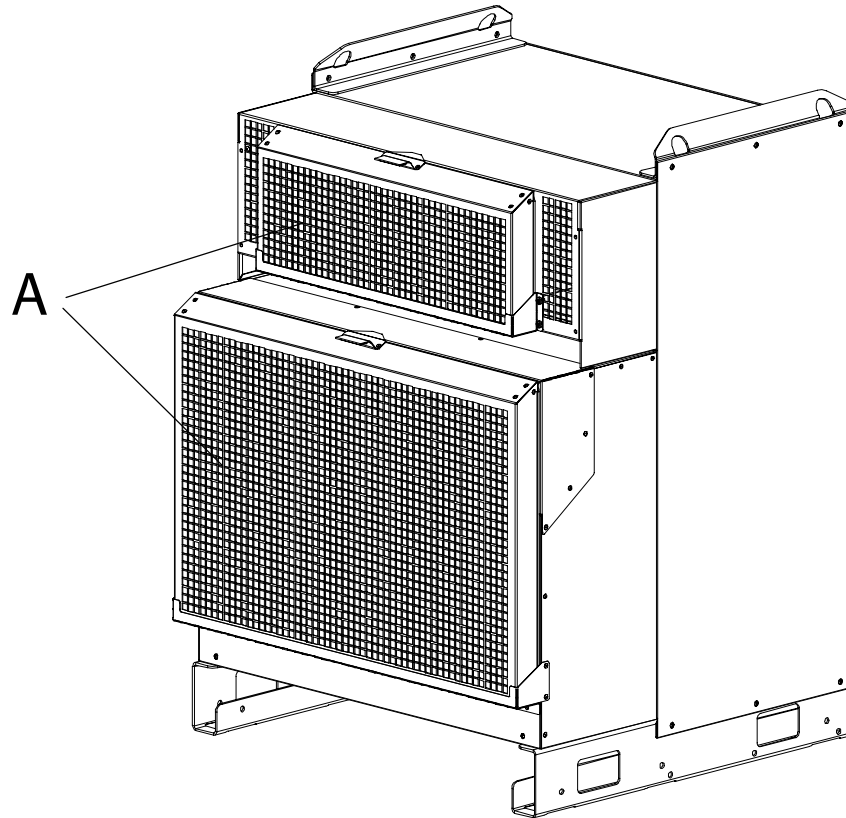

xx130000852

A	Moist dust filter magazine
---	----------------------------

Required equipment

Equipment	Note
Cleaning agent	Water 30-40 °C with cleansing liquid or detergent.
Compressed air	

Cleaning

The procedure below details how to clean the moist dust filter.

Action	Note/Illustration
1 Remove the moist dust filter.	How to remove the moist dust filter is detailed in section Replacement of moist dust filter on page 205 .
2 Clean the filter three or four times.	
3 Allow the filter to dry in one of these ways: <ul style="list-style-type: none"> • Lying flat on a flat surface • Blow with compressed air in opposite direction of filter airflow. 	Note Do not wring the filter out!

Continues on next page

3 Maintenance

3.4.2 Cleaning moist dust filter

Continued

	Action	Note/Illustration
4	Refit the moist dust filter.	

3.4.3 Cleaning the FlexPendant

Location

The surfaces to clean are shown in the illustration below.

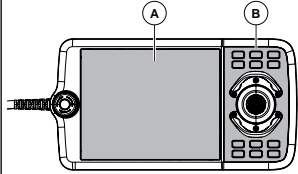
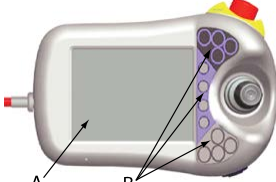
FlexPendant with emergency stop button at the connector		FlexPendant with emergency stop button at the outer edge	
 <p>xx1800000128</p>		 <p>xx0400000973</p>	
A	Touchscreen		
B	Hard buttons		

Required equipment

Equipment, etc.	Note
Soft cloth	ESD protected
Water/Mild cleaning agent	

Clean the touch screen

This section describes how to clean the touch screen.

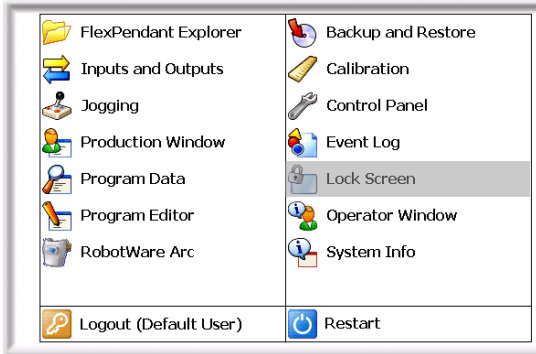
Action	Info/Illustration
1 Lock the screen.	 <p>en0400001221</p>

Continues on next page

3 Maintenance

3.4.3 Cleaning the FlexPendant

Continued

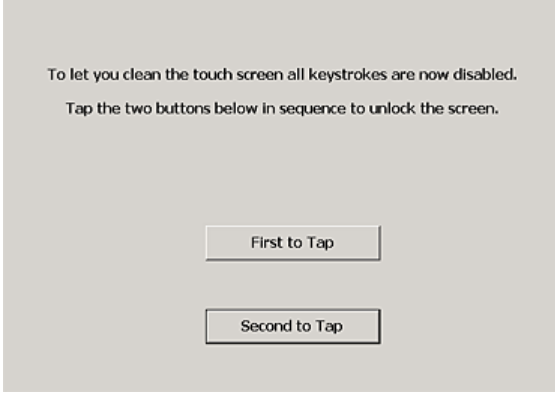
	Action	Info/Illustration
2	It is safe to clean the FlexPendant when the Lock screen appears.	 <p>en040000658</p>
3	Clean the touch screen and hardware buttons using a soft cloth and water or a mild cleaning agent.	
4	Unlock the screen, by tapping the buttons.	 <p>en040000658</p>

Cleaning considerations

The section below specifies some special considerations when cleaning the FlexPendant:

- Use ESD Protection
- Use cleaning equipment as specified above. Any other cleaning equipment may shorten the life time of the touch screen.
- Check that all protective covers are fitted to the device before cleaning.
- Make sure that no foreign objects or liquids can penetrate into the device.
- Do not remove any covers before cleaning the FlexPendant.
- Do not spray with a high pressure cleaner.
- Do not clean the device, operating panel and operating elements with compressed air, solvents, scouring agent or scrubbing sponges.

3.5 Function tests**3.5.1 Function test of earth fault breaker F4****Performing the function test**

	Action	Note
1	Start the robot system.	
2	Press the button with the text "test" on the earth fault breaker.	This test is passed if the earth fault breaker is released when pressing the test button. If the earth fault breaker did not release, the test failed and the root cause of the failure must be found.
3	After the test, reset the earth fault breaker.	

3 Maintenance

3.5.2 Function test of emergency stop

3.5.2 Function test of emergency stop

Overview

Perform this test on the emergency stop button both on the operating panel and on the FlexPendant.

Performing the function test

	Action	Note
1	Make a visual inspection of the emergency stop button to make sure it is not physically damaged.	If any damage is found on the emergency stop button, it must be replaced.
2	Start the robot system.	
3	Press the emergency stop button.	The test is passed if the event message 10013 Emergency stop state appears in the event log. If either of the following happens, then the test is failed and the root cause must be found: <ul style="list-style-type: none">• if the event message 10013 Emergency stop state does not appear• if the event message 90223 Emergency stop conflict appears
4	After the test, release the emergency stop button and press the motors on button to reset the emergency stop state.	

3.5.3 Function test of mode switch

2-position mode switch

	Action	Note
1	Start the robot system.	
2	Start with the mode switch in manual mode and then switch the mode switch to auto mode. Run the robot in auto mode.	This test is passed if it is possible to run the robot in auto mode. If it is not possible to run the robot in auto mode, this test is failed and the root cause of the failure must be found.
3	Switch the mode switch to manual mode.	This test is passed if the event message 10015 Manual mode selected appears in the event log. If the event message 10015 Manual mode selected is not shown, the test failed and the root cause of the failure must be found.

3-position mode switch

	Action	Note
1	Start the robot system.	
2	Start with the mode switch in manual mode and then switch the mode switch to auto mode. Run the robot in auto mode.	This test is passed if it is possible to run the robot in auto mode. If it is not possible to run the robot in auto mode, this test is failed and the root cause of the failure must be found.
3	Switch the mode switch to manual full speed mode. Run the program in manual full speed mode.	This test is passed if it is possible to run the program in manual full speed mode. If it is not possible to run the program in manual full speed mode, this test is failed and the root cause of the failure must be found.
4	Switch the mode switch to manual mode.	This test is passed if the event message 10015 Manual mode selected appears in the event log. If the event message 10015 Manual mode selected is not shown, the test failed and the root cause of the failure must be found.

3 Maintenance

3.5.4 Function test of three-position enabling device

3.5.4 Function test of three-position enabling device

Performing the function test

	Action	Note
1	Start the robot system and turn the mode switch to manual mode.	
2	Press the three-position enabling device to the middle position and then hold the enabling device in this position.	This test is passed if the event message 10011 Motors ON state appears in the event log. If either of the following happens, then the test is failed and the root cause must be found: <ul style="list-style-type: none">• if the event message 10011 Motors ON state does not appear• if the event message 90224 Enabling Device conflict appears
3	While still holding the three-position enabling device pressed, press the enabling device harder to the enable the device's third position.	This test is passed if the event message 10012 Safety guard stop state appears in the event log. If either of the following happens, then the test is failed and the root cause must be found: <ul style="list-style-type: none">• if the event message 10012 Safety guard stop state does not appear• if the event message 90224 Enabling Device conflict appears

3.5.5 Function test of motor contactors K42 and K43

Performing the function test

	Action	Note
1	Start the robot system and turn the mode switch to manual mode.	
2	Press the three-position enabling device to the middle position and then hold the enabling device in this position.	This test is passed if the event message 10011 Motors ON state appears in the event log. If the event message 37001 Motor on activation error appears, the test is failed and the root cause of the failure must be found.
3	Release the three-position enabling device.	This test is passed if the event message 10012 safety guard stop state appears in the event log. If the event message 90227 Motor contactor conflict appears, the test is failed and the root cause of the failure must be found.

3 Maintenance

3.5.6 Function test of brake contactor K44

3.5.6 Function test of brake contactor K44

Performing the function test

	Action	Note
1	Start the robot system and turn the mode switch to manual mode.	
2	Press the three-position enabling device to the middle position and then hold the enabling device in this position. While having eye contact with the manipulator, move the joystick slightly in any direction to disengage the brakes.	This test is passed if the brakes is disengaged and the manipulator can be moved. If the event message 50056 Joint collision appears in the event log, the test is failed and the root cause of the failure must be found.
3	Release the three-position enabling device to engage the brakes.	This test is passed if the event message 10012 safety guard stop state appears in the event log. If the event message 37101 Brake failure appears, the test is failed and the root cause of the failure must be found.

3.5.7 Function test of Automatic Stop

Performing the function test

	Action	Note
1	Start the robot system and change the operating mode to auto mode.	
2	Activate the Automatic Stop, for example by opening the connected robot cell door, which has interlock connection with Automatic Stop.	The test is passed if the event message 90205 Auto Stop open appears in the event log. If the event message 90205 Auto Stop open does not appear or if the event message 90225 Auto Stop conflict appears in the event log, then the test has failed and the root cause of the failure must be found.

3 Maintenance

3.5.8 Function test of General Stop

3.5.8 Function test of General Stop

Performing the function test

	Action	Note
1	Start the robot system.	
2	Activate the General Stop.	<p>The test is passed if the event message 90206 General Stop open appears in the event log.</p> <p>If either of the following happens, then the test is failed and the root cause must be found:</p> <ul style="list-style-type: none">• if the event message 90206 General Stop open does not appear• if the event message 90226 General Stop conflict appears

3.5.9 Function test of superior stop

Performing the function test

	Action	Note
1	Start the robot system.	
2	Activate the superior stop.	<p>The test is passed if the event message 90215 Superior Stop open appears in the event log.</p> <p>If either of the following happens, then the test is failed and the root cause must be found:</p> <ul style="list-style-type: none">• if the event message 90215 Superior Stop open does not appear• if the event message 90220 Superior Stop conflict appears

3 Maintenance

3.5.10 Function test of limit switch

3.5.10 Function test of limit switch

Testing limit switches on manipulator

This must be tested on all the axes that has mounted limit switches.

	Action	Note
1	Start the robot system.	
2	Jog the axis under test to the limit switch activation position.	The test is passed if the event message 90214 Limit switch open appears in the FlexPendant log when the axis reaches the limit switch activation position. If either of the following happens, then the test is failed and the root cause must be found: <ul style="list-style-type: none">• if the event message 90214 Limit switch open does not appear• if the event message 90222 Limit switch conflict appears
3	After the test the robot must be jogged out of the limit switch activation position again. This is done by jogging the robot after pressing the limit switch override push button. See Connecting a Limit switch override push button on page 114 .	

Testing limit switches for a SafeMove system

Perform validation of the function Safe Axis Speed. See *Application manual - SafeMove1*. If this test is passed the limit switch works as intended.

3.5.11 Function test of automatic fuse F1**Performing the function test**

	Action	Note
1	Start the robot system.	
2	To test the automatic fuse, insert a screw driver in the test opening.	This test is passed if the automatic fuse is released when inserting the screw driver in the test opening. If the automatic fuse did not release, the test failed and the root cause of the failure must be found.
3	After the test, reset the automatic fuse.	

3 Maintenance

3.5.12 Function test of reduced speed control

3.5.12 Function test of reduced speed control

Performing the function test

	Action	Note
1	Start the robot system and change the operating mode to manual.	
2	Create a test program where the robot moves along a known distance with a programmed speed higher than 250 mm/s.	The distance and speed must be adapted to the current installation and robot model.
3	<p>Start the program in manual mode and measure the time it takes for the robot to travel the distance.</p> <p> Tip</p> <p>To get accurate results, use sensors or I/O signals to measure the time.</p>	This test is passed if the speed of the robot does not exceed 250 mm/s, otherwise the test is failed and the root cause of the failure must be found.

4 Repair

4.1 Overview

General

The ABB IRC5 controller has all components in one cabinet.

Additional drive modules can be connected to the controller. These are used in MultiMove applications where one controller is controlling up to four manipulators.

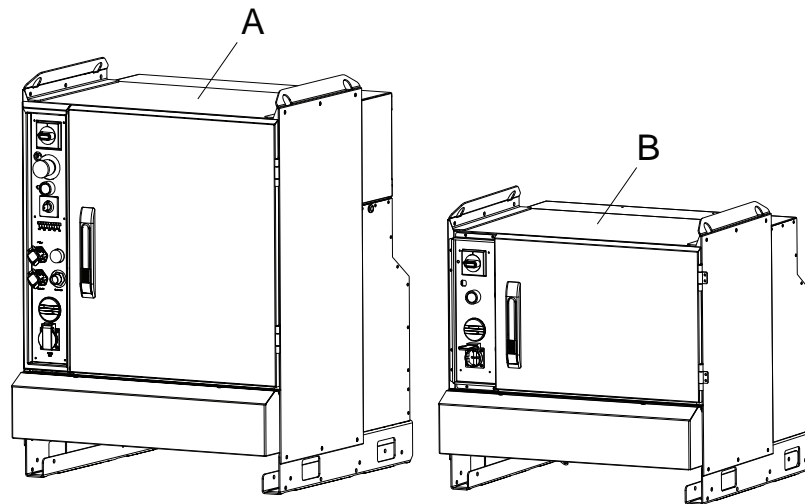

xx130000678

A	IRC5 controller
B	Additional drive module

The IRC5 controller is regarded as the standard configuration and therefore the illustration in the procedures detailed in this manual are based on that.

If the procedure in general is the same, it is mentioned in each procedure where the part is located in the IRC5 controller. If there are significant differences, both the IRC5 controller and the drive module configurations are shown.



Note

When replacing a part on the IRC5, report to your local ABB the serial number, the article number, and the revision of both the replaced unit and the replacement unit.

This is particularly important for safety equipment to maintain the safety integrity of the installation.

4 Repair

4.2 Replacement of panel board

4.2 Replacement of panel board

Location

The panel board unit, DSQC 643, is located as shown in the illustration below.

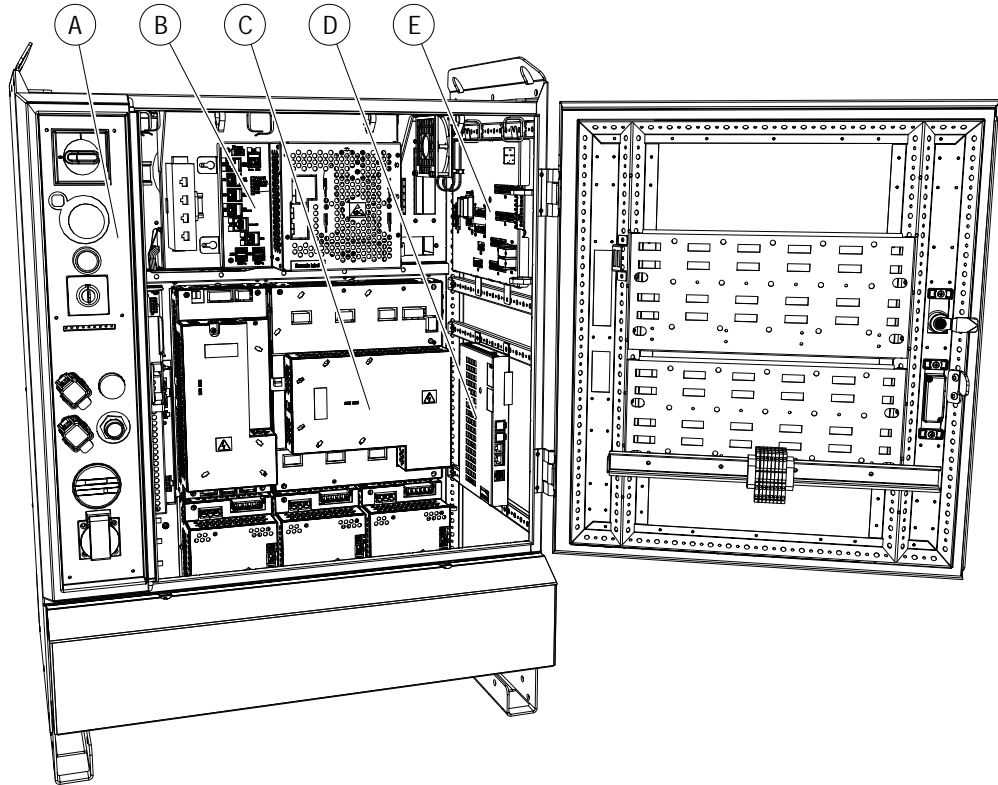

xx130000679

A	Operator's panel
B	Computer unit
C	Drive system
D	Axis computer
E	Panel board unit



Required equipment

Equipment	Note
Panel board unit	DSQC 643 See Spare parts on page 327 .
Standard toolkit	The contents are defined in section Standard toolkit!
Other tools and procedures may be required. See references to these procedures in the step-by-step instructions below.	These procedures include references to the tools required.
Circuit diagram	See Circuit diagrams on page 349 .

Continues on next page

Removal

The procedure below details how to remove the panel board unit.

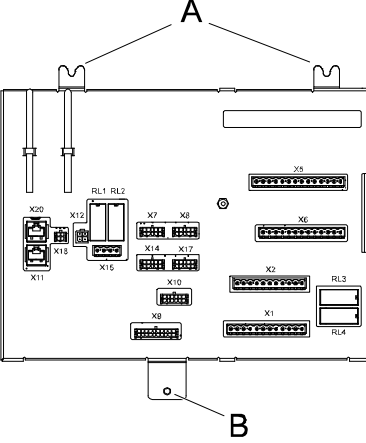
Action	Note/Illustration
<p>1</p>  <p>DANGER</p> <p>Before doing any work inside the cabinet, disconnect the mains power. For more information, see Electrical safety on page 37.</p>	
<p>2</p>  <p>ELECTROSTATIC DISCHARGE (ESD)</p> <p>The unit is sensitive to ESD. Before handling the unit read the safety information in section The unit is sensitive to ESD on page 49.</p>	
<p>3</p> <p>Disconnect all connectors.</p>	 <p>Note</p> <p>Make a note of any connections.</p>
<p>4</p> <p>Remove the lower attachment screw, and remove the Panel Unit.</p>	 <p>xx0400000812</p> <ul style="list-style-type: none"> • A: fixed attachments • B: hole for attachment screw

Refitting

The procedure below details how to refit the panel board unit.

Action	Note/Illustration
<p>1</p>  <p>DANGER</p> <p>Before doing any work inside the cabinet, disconnect the mains power. For more information, see Electrical safety on page 37.</p>	

Continues on next page

4 Repair

4.2 Replacement of panel board

Continued

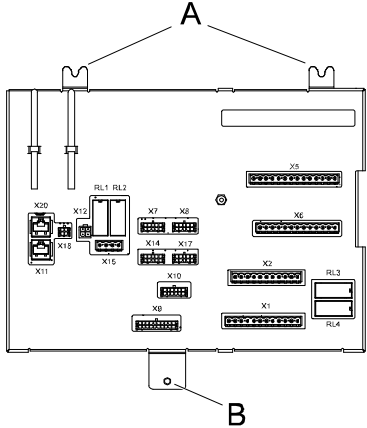
	Action	Note/Illustration
2	 ELECTROSTATIC DISCHARGE (ESD) The unit is sensitive to ESD. Before handling the unit read the safety information in section <i>The unit is sensitive to ESD on page 49</i> .	
3	Refit the panel board unit.	
4	Refit the lower attachment screw.	 <p>xx0400000812</p> <ul style="list-style-type: none"> • A: fixed attachments • B: hole for attachment screw
5	Reconnect all connectors.	
6	Perform the function tests in section <i>Function tests on page 213</i> to verify that the safety features work properly.	

4.3 Replacement of Flange disconnect

Location

The Flange disconnect unit is located as shown in the illustration below.

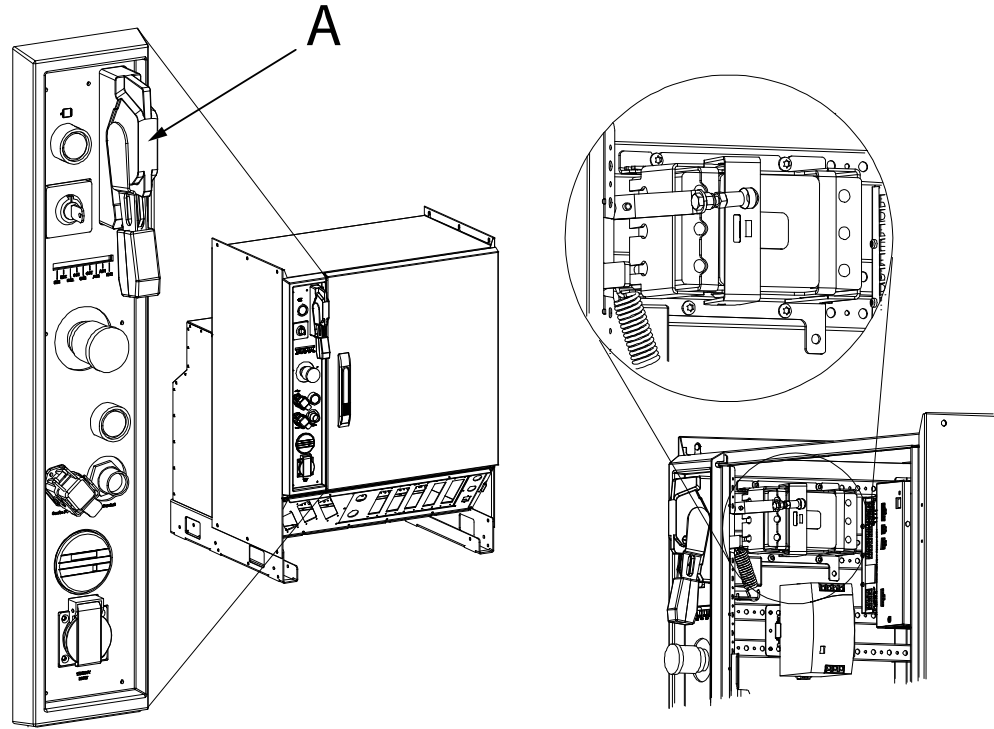

xx0600003133

A	Flange disconnect
---	-------------------

Required equipment

Equipment	Art. no.	Note
Flange disconnect	3HAC027113-001	
Standard toolkit		The contents are defined in section Standard toolkit!
Other tools and procedures may be required. See references to these procedures in the step-by-step instructions below.		These procedures include references to the tools needed.
Circuit diagram		See Circuit diagrams on page 349 .

Continues on next page



4 Repair

4.3 Replacement of Flange disconnect

Continued

Removal

The procedure below details how to remove the Flange disconnect unit.

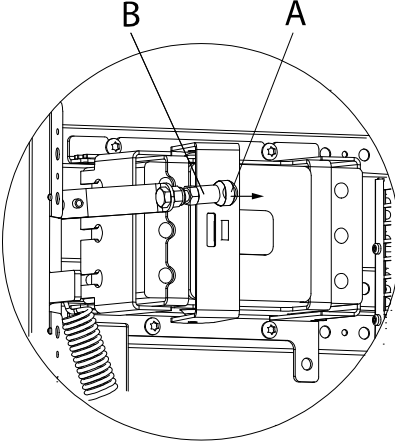
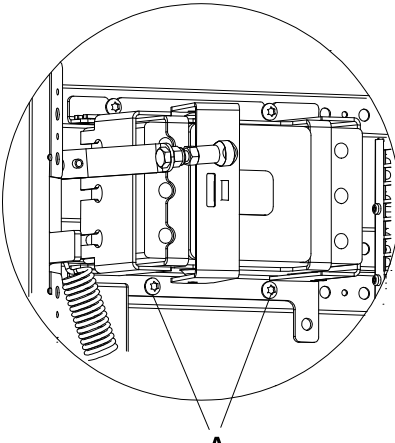
	Action	Note/Illustration
1	<p> DANGER</p> <p>Before doing any work inside the cabinet, disconnect the mains power. For more information, see Electrical safety on page 37.</p>	
2	<p>Remove the link by pushing the spring forward.</p> <p> WARNING</p> <p>Be careful when removing the link. The link is spring-loaded and the spring can with high force pull the link down when it is released.</p>	 <p>xx0600003141</p> <ul style="list-style-type: none">• A: spring• B: link
3	Remove the two lower attachment screws.	 <p>xx0600003139</p> <ul style="list-style-type: none">• A: attachment screws

Continues on next page

4.3 Replacement of Flange disconnect
Continued

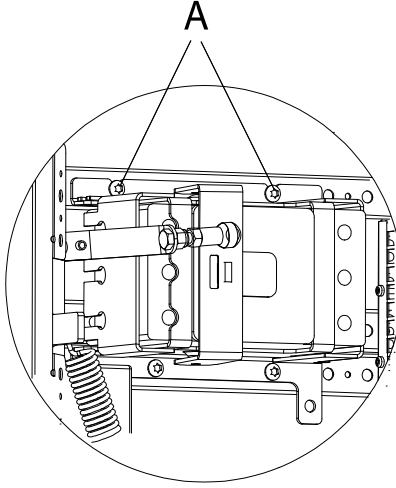
	Action	Note/Illustration
4	Loosen the two upper attachment screws and remove the unit.	 <p data-bbox="1034 801 1145 824">xx0600003140</p> <ul data-bbox="1066 831 1348 853" style="list-style-type: none"> • A: attachment screws
5	Disconnect the cables.	

Refitting

The procedure below details how to refit the Flange disconnect unit.

	Action
1	 DANGER Before doing any work inside the cabinet, disconnect the mains power. For more information, see Electrical safety on page 37 .
2	Reconnect the cables.
3	Refit the unit and fasten the two upper attachment screws.
4	Refit the two lower attachment screws.
5	Refit the link to the unit.
6	Perform the function tests in section Function tests on page 213 to verify that the safety features work properly.

4 Repair

4.4 Replacement of I/O units and Gateways

4.4 Replacement of I/O units and Gateways

General

A number of I/O units and gateway units may be installed in the controller. These are specified in [DeviceNet I/O units on page 129](#).

How to configure the I/O units is detailed in *Operating manual - RobotStudio*.

Location

The location of the I/O units, gateway units, or encoder interface units are shown in the illustration below.

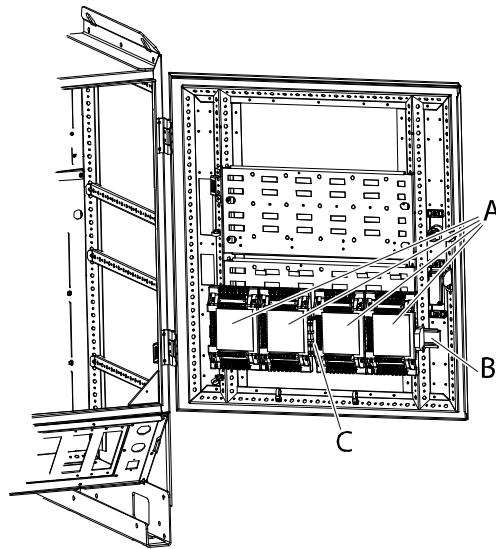

xx0500001859

A	Gateway, I/O Units or encoder interface units
B	Mounting rail
C	Connection terminal XT31



Required equipment

Equipment	Note
A number of units are available.	Specified in section DeviceNet I/O units on page 129 .
Standard toolkit	The contents are defined in section Standard toolkit!
Other tools and procedures may be required. See references to these procedures in the step-by-step instructions below.	These procedures include references to the tools required.
Circuit diagram	See Circuit diagrams on page 349 .

Continues on next page



Removal

The procedure below details how to remove the I/O units or gateway units.

	Action	Note/illustration
1	 DANGER Before doing any work inside the cabinet, disconnect the mains power. For more information, see Electrical safety on page 37 .	
2	 ELECTROSTATIC DISCHARGE (ESD) The unit is sensitive to ESD. Before handling the unit read the safety information in section The unit is sensitive to ESD on page 49 .	
3	Identify the I/O unit or gateway unit to be replaced.	
4	Disconnect the connectors from the unit.	Note which connector goes where, to facilitate reassembly.
5	Tip the unit away from the mounting rail and remove it.	

Refitting

The procedure below details how to refit the I/O units or gateway units.

	Action	Note/illustration
1	 DANGER Before doing any work inside the cabinet, disconnect the mains power. For more information, see Electrical safety on page 37 .	
2	 ELECTROSTATIC DISCHARGE (ESD) The unit is sensitive to ESD. Before handling the unit read the safety information in section The unit is sensitive to ESD on page 49 .	
3	Hook the unit back onto the mounting rail and snap it gently in position.	
4	Reconnect all connectors disconnected during removal.	
5	Perform the function tests in section Function tests on page 213 to verify that the safety features work properly.	

4 Repair

4.5 Replacement of backup energy bank

4.5 Replacement of backup energy bank

Location

The illustration below shows the location of the backup energy bank in the IRC5 controller.

The backup energy bank is located behind the main computer attachment plate.

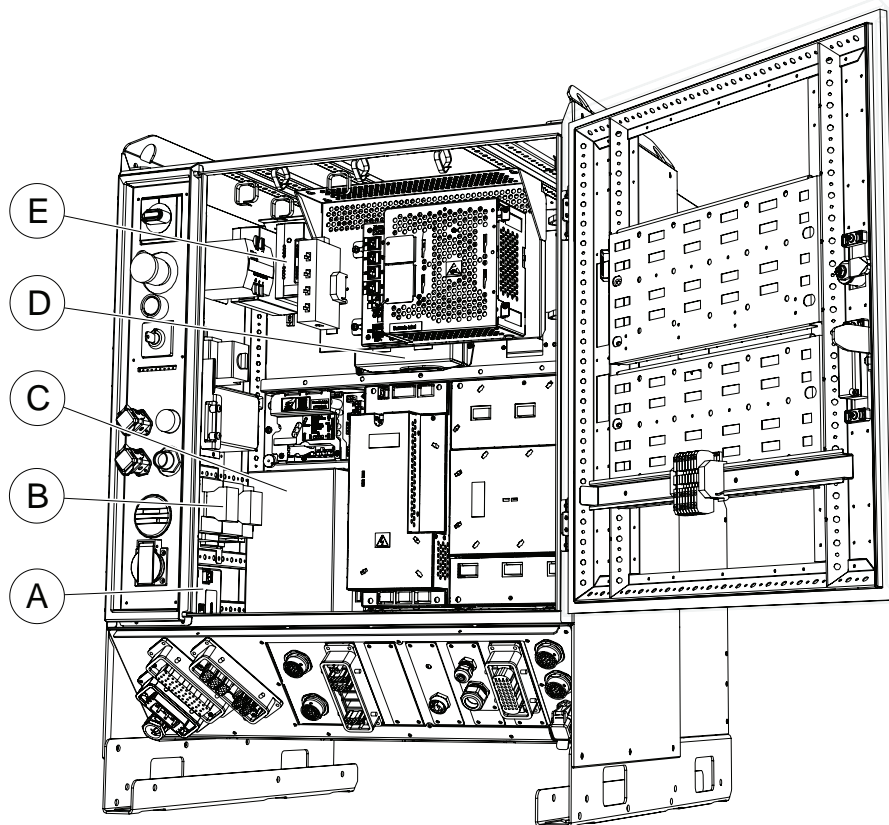

xx1300000680

A	Contactor interface board
B	Contactor
C	Drive system power supply
D	Backup energy bank Customer I/O power supply
E	Control power supply

Required equipment

Equipment	Note
Backup energy bank	DSQC 655 with or without adapter plate. See Spare parts on page 327 .
Standard toolkit	The contents are defined in section Standard toolkit.

Continues on next page

Equipment	Note
Other tools and procedures may be required. See references to these procedures in the step-by-step instructions below.	These procedures include references to the tools required.
Circuit diagram	See Circuit diagrams on page 349 .

Removal

The procedure below details how to remove the backup energy bank.

	Action	Note/Illustration
1	 DANGER Before doing any work inside the cabinet, disconnect the mains power. For more information, see Electrical safety on page 37 .	
2	Disconnect the connector X4 from the distribution board.	
3	Remove the <i>attachment screw</i> .	
4	Pull the <i>backup energy bank</i> out.	

Refitting

The procedure below details how to refit the backup energy bank.

	Action
1	 DANGER Before doing any work inside the cabinet, disconnect the mains power. For more information, see Electrical safety on page 37 .
2	Refit the new backup energy bank.
3	Refit and tighten the <i>attachment screw</i> .
4	Reconnect the connector to the <i>control power supply</i> connector X4.
5	Refit the front with the Panel Board Unit.
6	Perform the function tests in section Function tests on page 213 to verify that the safety features work properly.

4 Repair

4.6 Replacement of heat exchange unit and fan

4.6 Replacement of heat exchange unit and fan

Location

The heat exchanger unit is located in the back of the controller as shown below.

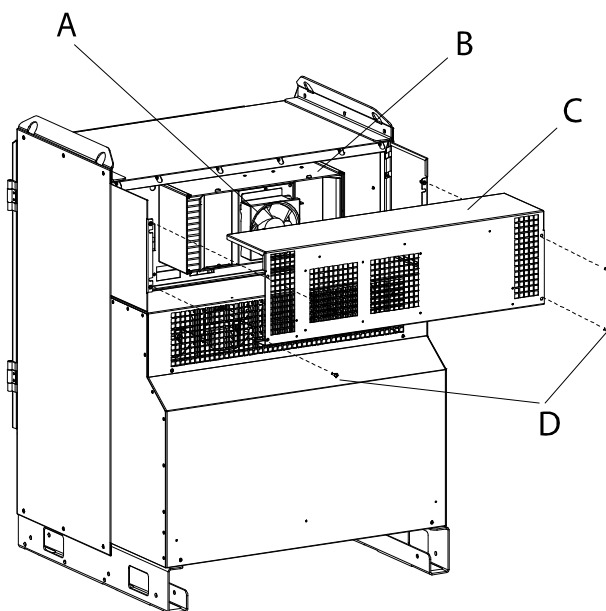

xx0500001952

A	Fan
B	Heat exchanger
C	Top cover
D	Attachment screws (4 pcs)

Required equipment

Equipment	Note
Fan	See Spare parts on page 327 .
Heat exchange unit	See Spare parts on page 327 .
Standard toolkit	The contents are defined in section Standard toolkit, IRC5 on page 323 .
Other tools and procedures may be required. See references to these procedures in the step-by-step instructions below.	These procedures include references to the tools required.
Circuit diagram	See Circuit diagrams on page 349 .

Continues on next page

Removal of heat exchanger fan

The procedure below details how to remove the heat exchange unit fan.

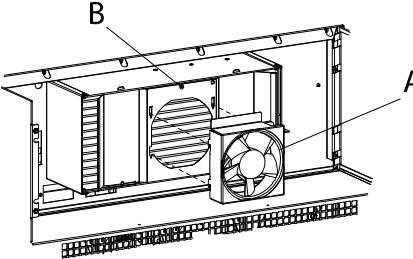
	Action	Note/illustration
1	 DANGER Before doing any work inside the cabinet, disconnect the mains power. For more information, see Electrical safety on page 37 .	
2	Remove the attachment screws on the top cover.	
3	Remove the <i>top cover</i> .	Shown in the figure above.
4	Disconnect the connector to the fan.	
5	Remove the screw (item B in image below).	
6	Push the fan upwards, and pull it out.	 <p>xx0500001954</p> <ul style="list-style-type: none"> • A: fan • B: screw

Refitting of heat exchanger fan

The procedure below details how to refit the heat exchange unit fan.

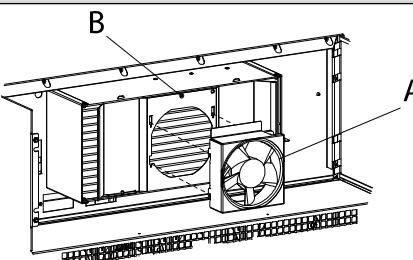
	Action	Note/illustration
1	Put the new fan in place, and push down.	 <p>xx0500001954</p> <ul style="list-style-type: none"> • A: fan • B: screw
2	Refit the screw (item B in image above).	
3	Reconnect the connector to fan.	

Continues on next page

4 Repair

4.6 Replacement of heat exchange unit and fan

Continued

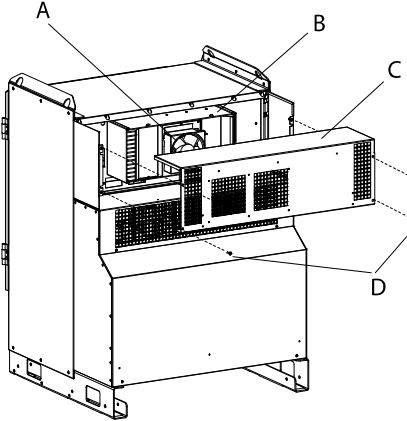
	Action	Note/illustration
4	Refit the top cover.	 <p>xx0500001952</p> <ul style="list-style-type: none"> • A: fan • B: heat exchanger • C: top cover • B: attachment screws (4 pcs)
5	Refit the <i>attachment screws</i> .	Shown in the figure above.
6	Perform the function tests in section <i>Function tests on page 213</i> to verify that the safety features work properly.	

Removal of heat exchange unit

The procedure below details how to remove the heat exchange unit.

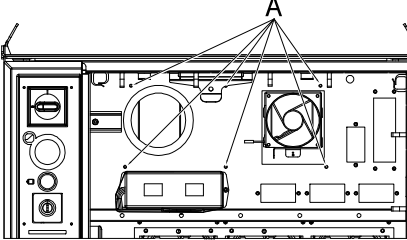
	Action	Note/illustration
1	 <p>DANGER</p> <p>Before doing any work inside the cabinet, disconnect the mains power. For more information, see <i>Electrical safety on page 37</i>.</p>	
2	Follow step 2 through 5 in <i>Removal of heat exchanger fan on page 237</i> .	
3	Have one person holding the heat exchange unit while another person unscrews the attachment screws from inside the controller cabinet.	 <p>xx1000000973</p> <ul style="list-style-type: none"> • A: attachment screw for heat exchange unit

Continues on next page

Refitting of heat exchange unit

The procedure below details how to refit the heat exchange unit.

Have one person hold the heat exchange unit in place while another person fits the attachment screws from inside the controller cabinet.

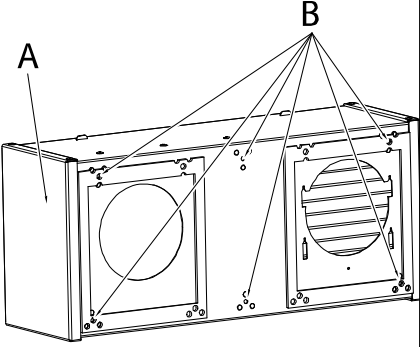
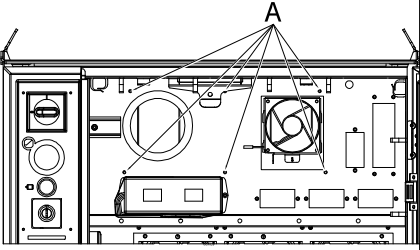
	Action	Note/illustration
1	Hold the heat exchange unit against the controller so that the screw holes in the heat exchange unit are aligned with the holes in the controller cabinet.	 <p>xx100000974</p> <ul style="list-style-type: none"> • A: heat exchange unit • B: screw holes
2	Fit the attachment screws through the holes in the controller cabinet and screw them into the heat exchange unit.	 <p>xx100000973</p> <ul style="list-style-type: none"> • A: holes in the controller cabinet for attaching the heat exchange unit
3	Follow the step 1 to 4 in Refitting of heat exchanger fan on page 237 .	
4	Perform the function tests in section Function tests on page 213 to verify that the safety features work properly.	

4 Repair

4.7 Replacement of computer unit

4.7 Replacement of computer unit

Location

The computer unit is located as shown in the illustration below.

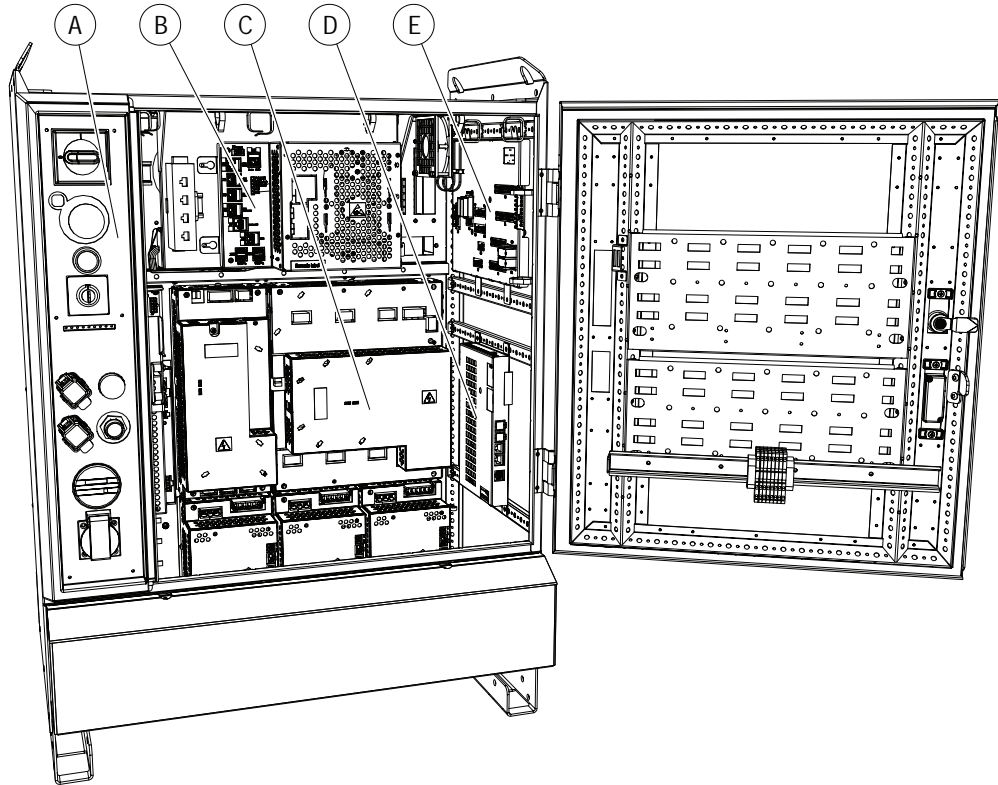

xx130000679

A	Operator's panel
B	Computer unit
C	Drive system
D	Axis computer
E	Panel board unit

Required equipment

Equipment	Note
Computer unit	See Spare parts on page 327 .
Standard toolkit	The contents are defined in section Standard toolkit.
Other tools and procedures may be required. See references to these procedures in the step-by-step instructions below.	These procedures include references to the tools required.
Circuit diagram	See Circuit diagrams on page 349 .

Removal



The procedure below details how to remove the computer unit.

Continues on next page



Note

If possible, do a backup of the system before removing the computer unit. For information on how to do a backup see *Operating manual - IRC5 with FlexPendant*.

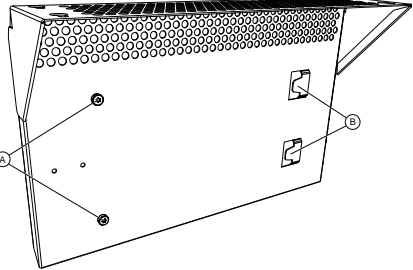
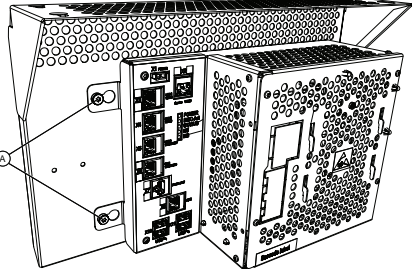

	Action	Note/illustration
1	 <p>DANGER</p> <p>Before doing any work inside the cabinet, disconnect the mains power. For more information, see Electrical safety on page 37.</p>	
2	 <p>ELECTROSTATIC DISCHARGE (ESD)</p> <p>The unit is sensitive to ESD. Before handling the unit read the safety information in section The unit is sensitive to ESD on page 49.</p>	
3	<p>Disconnect all connectors from the computer unit.</p>	 <p>Tip</p> <p>Make a note of the connections.</p>
4	<p>The computer unit is suspended by attachment screws to the left, and latches to the right.</p>	 <p>xx1300000683</p> <p>A Attachment screws B Latches</p>
5	<p>Loosen the attachment screws.</p>	 <p>xx1300000681</p> <p>A Attachment screws</p>

Continues on next page

4 Repair

4.7 Replacement of computer unit

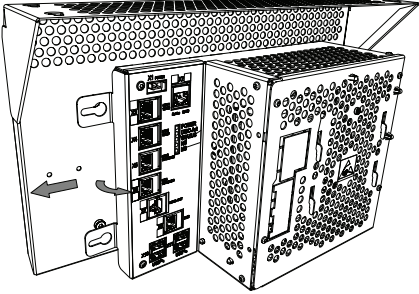
Continued

	Action	Note/illustration
6	Support the computer unit beneath by hand and pull the computer unit in the arrow direction.	 <p data-bbox="965 613 1070 633">xx130000682</p> <p data-bbox="965 658 1174 719">  WARNING </p> <p data-bbox="965 734 1385 813">Prevent the computer unit from falling down due to gravity by supporting the computer unit from beneath by hand.</p>



Refitting

The procedure below describes how to refit the computer unit.



Note

After replacing the main computer, the RobotWare system can be reset. It is then necessary to restore a backup. For information on how to restore a backup see *Operating manual - IRC5 with FlexPendant*.

	Action	Note/illustration
1	 DANGER Before doing any work inside the cabinet, disconnect the mains power. For more information, see Electrical safety on page 37 .	
2	 ELECTROSTATIC DISCHARGE (ESD) The unit is sensitive to ESD. Before handling the unit read the safety information in section The unit is sensitive to ESD on page 49 .	

Continues on next page

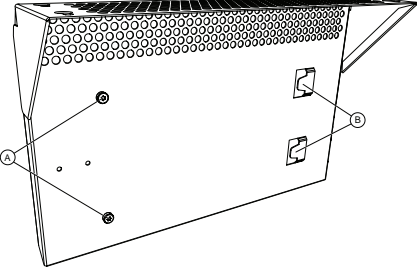
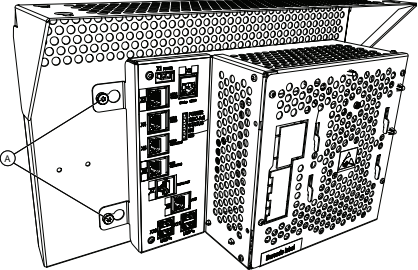
	Action	Note/illustration
3	The computer unit is suspended by attachment screws to the left, and latches to the right.	 <p data-bbox="997 591 1102 607">xx1300000683</p> <p data-bbox="1027 629 1281 685">A Attachment screws B Latches</p>
4	Fit the computer unit in position.	
5	Tighten the attachment screws.	 <p data-bbox="997 1025 1102 1041">xx1300000681</p> <p data-bbox="1027 1064 1281 1093">A Attachment screws</p>
6	Reconnect all connectors to the computer unit.	
7	Perform the function tests in section Function tests on page 213 to verify that the safety features work properly.	

4 Repair

4.8 Replacement of PClexpress boards in the computer unit

4.8 Replacement of PClexpress boards in the computer unit

Location

The following PClexpress boards may be fitted in the slots in the computer unit as shown in the figure below:

- DeviceNet Master/Slave
- PROFIBUS-DP Master
- Safety module (second generation SafeMove safety controller)

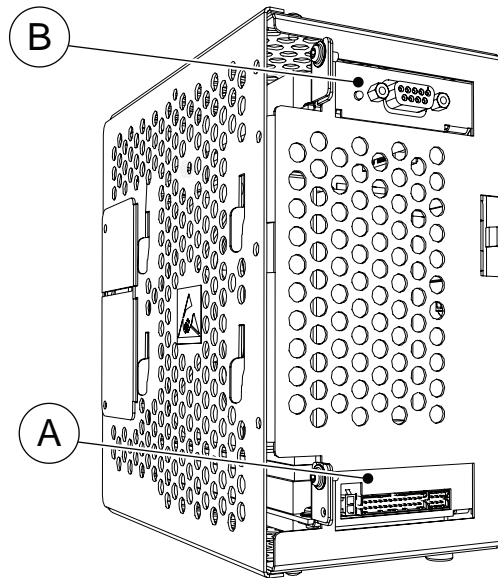

xx1500001760

A	Safety module DSQC1015
B	PClexpress slot for other devices.

Required equipment

Equipment	Art. no.	Note
Profibus-DP Master	3HAC044872-001	DSQC1005 Profibus communication is described in <i>Application manual - PROFIBUS Controller</i> .
DeviceNet Master/Slave	3HAC043383-001	DSQC1006 DeviceNet communication is described in <i>Application manual - DeviceNet Master/Slave</i> .
Safety module	3HAC048858-001	DSQC1015 SafeMove (2nd generation) is described in <i>Application manual - Functional safety and SafeMove2</i> .
Standard toolkit		The contents are described in section Standard toolkit, IRC5 on page 323 .

Continues on next page

4.8 Replacement of PCIeexpress boards in the computer unit

Continued





Equipment	Art. no.	Note
Other tools and procedures may be required. See references to these procedures in the step-by-step instructions below.		These procedures include references to tools required.

References

Equipment	Art. no.	Note
Application manual - PROFIBUS Controller	3HAC050966-001	Contains information on how to configure the system for PROFIBUS devices.
Application manual - DeviceNet Master/Slave	3HAC050992-001	Contains information on how to configure the system for DeviceNet devices.
Circuit diagram	See Circuit diagrams on page 349 .	

Removal

The procedure below details how to remove a PCIeexpress board.

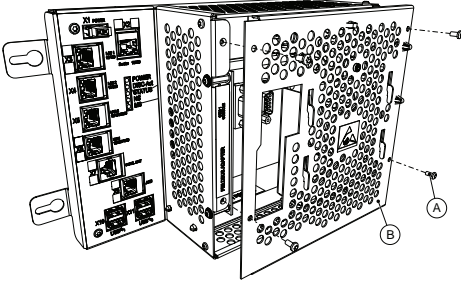

	Action	Note/Illustration
1	 DANGER Before doing any work inside the cabinet, disconnect the mains power. For more information, see Electrical safety on page 37 .	
2	 ELECTROSTATIC DISCHARGE (ESD) The unit is sensitive to ESD. Before handling the unit read the safety information in section The unit is sensitive to ESD on page 49 .	
3	Disconnect any cables to/from the PCIeexpress board.	 Tip Make a note of which cables are disconnected.
4	Open the computer unit by removing the attachment screws and lift off the upper cover. Disconnect the fan connector.  CAUTION Be careful with the fan cable when opening and removing the upper cover. The fan cable must not be stretched.	 xx1300000684 A Attachment screws (4 pcs.) B Upper cover

Continues on next page

4 Repair

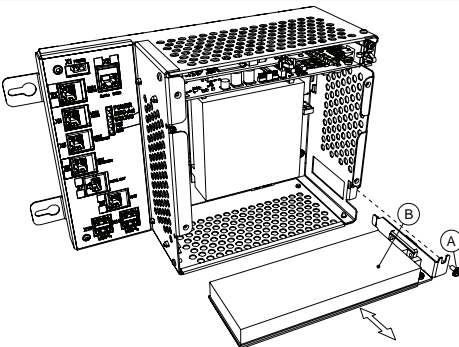

4.8 Replacement of PCIe boards in the computer unit

Continued

	Action	Note/Illustration
5	Remove the attachment screw on top of the PCIe board bracket.	 <p>xx130000685</p> <p>A Attachment screw B PCIe board</p>
6	Gently pull the board straight out.	<p> CAUTION</p> <p>Always grip the board around the edges to avoid damage to the board or its components.</p> <p> CAUTION</p> <p>Immediately put the board in an ESD safe bag or similar.</p>

Refitting

The procedure below details how to refit a PCIe board.

	Action	Note/Illustration
1	<p> DANGER</p> <p>Before doing any work inside the cabinet, disconnect the mains power. For more information, see Electrical safety on page 37.</p>	
2	<p> ELECTROSTATIC DISCHARGE (ESD)</p> <p>The unit is sensitive to ESD. Before handling the unit read the safety information in section The unit is sensitive to ESD on page 49.</p>	

Continues on next page

4.8 Replacement of PCIe boards in the computer unit

Continued

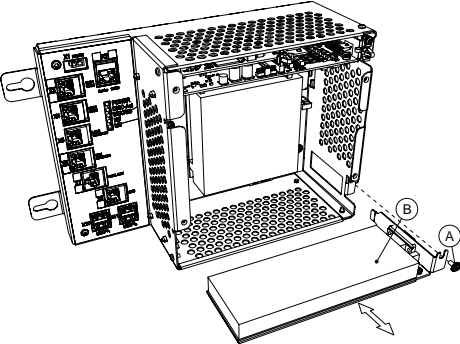
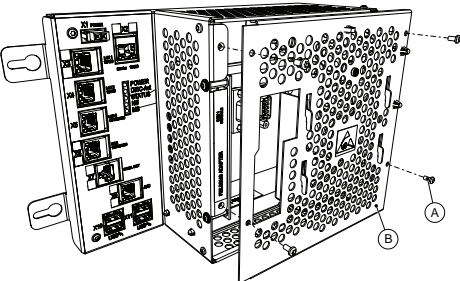
	Action	Note/Illustration
3	Fit the PCIe board in position by pushing the PCIe board into the socket on the motherboard.	 <p>xx130000685</p> <p>A Attachment screw B PCIe board</p> <p>! CAUTION</p> <p>Always grip the board around the edges to avoid damage to the board or its components.</p>
4	Refit the attachment screw on top of the PCIe board bracket.	
5	Reconnect any additional cables to the PCIe board.	
6	Refit the fan connector and close the computer unit. <p>! CAUTION</p> Be careful with the fan cable when closing the upper cover. The fan cable must not be squeezed.	 <p>xx130000684</p> <p>A Attachment screws (4 pcs.) B Upper cover</p>
7	Make sure the robot system is configured to support the installed PCIe board.	
8	Perform the function tests in section Function tests on page 213 to verify that the safety features work properly.	

4 Repair

4.9 Replacement of expansion board in the computer unit

4.9 Replacement of expansion board in the computer unit

Location

To connect a serial channel or a fieldbus adapter to the controller, the main computer must be equipped with the expansion board DSQC1003.

The expansion board is located in the computer unit as shown below.

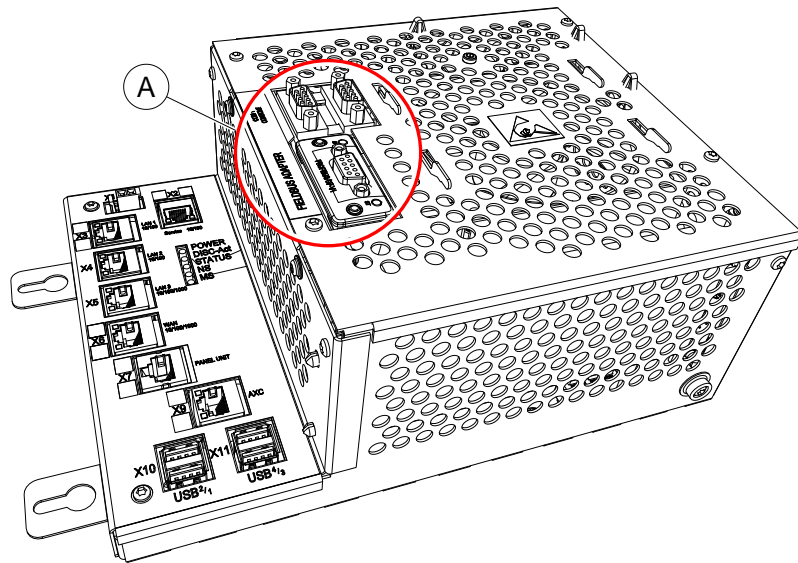

xx1300000860

A	Expansion board with serial channel and one slot for AnybusCC fieldbus adapter.
---	---

Required equipment

Equipment	Art. no.	Note
Expansion Board	3HAC046408-001	DSQC1003
Standard toolkit		The contents are described in section Standard toolkit, IRC5 on page 323 .

Removal





The following procedure describes how to remove the expansion board from the computer unit.

	Action	Note/Illustration
1	 DANGER Before doing any work inside the cabinet, disconnect the mains power. For more information, see Electrical safety on page 37 .	

Continues on next page

4.9 Replacement of expansion board in the computer unit

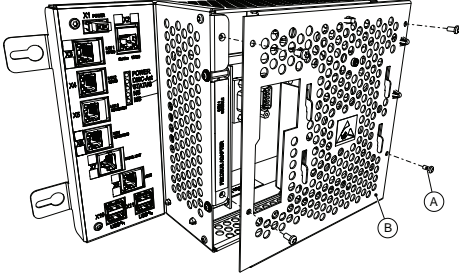
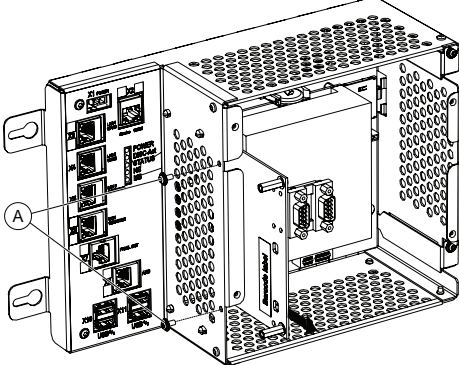
Continued

	Action	Note/Illustration
2	 <p>ELECTROSTATIC DISCHARGE (ESD)</p> <p>The unit is sensitive to ESD. Before handling the unit read the safety information in section <i>The unit is sensitive to ESD on page 49.</i></p>	
3	<p>Disconnect any cables to/from the fieldbus adapter.</p>	
4	<p>Open the computer unit by removing the attachment screws and lift off the upper cover. Disconnect the fan connector.</p> <p> CAUTION</p> <p>Be careful with the fan cable when opening and removing the upper cover. The fan cable must not be stretched.</p>	 <p>xx130000684</p> <p>A Attachment screws (4 pcs.) B Upper cover</p>
5	<p>If there is a fieldbus adapter, remove it.</p>	<p>See <i>Replacement of fieldbus adapter in the computer unit on page 251.</i></p>
6	<p>Remove the attachment screws on the computer unit.</p>	 <p>xx130000859</p> <p>A Attachment screws (2 pcs)</p>
7	<p>Grip the expansion board and gently pull it straight out.</p>	<p> CAUTION</p> <p>Always grip the expansion board around the edges to avoid damage to the board or its components.</p>

Continues on next page





4 Repair

4.9 Replacement of expansion board in the computer unit

Continued

Refitting

The following procedure describes how to refit the expansion board in the computer unit.

	Action	Note/Illustrator
1	 DANGER Before doing any work inside the cabinet, disconnect the mains power. For more information, see Electrical safety on page 37 .	
2	 ELECTROSTATIC DISCHARGE (ESD) The unit is sensitive to ESD. Before handling the unit read the safety information in section The unit is sensitive to ESD on page 49 .	
3	Fit the expansion board in position by pushing the expansion board into the connector on the motherboard.  CAUTION Push carefully so no pins are damaged. Make sure that the expansion board is pushed straight into the connector.	 CAUTION Always grip the expansion board around the edges to avoid damage to the board or its components.
4	Secure the expansion board in the computer unit with the attachment screws.	
5	Refit the fan connector and close the computer unit.  CAUTION Be careful with the fan cable when closing the upper cover. The fan cable must not be squeezed.	
6	Reconnect any cable to the fieldbus adapter.	
7	Perform the function tests in section Function tests on page 213 to verify that the safety features work properly.	

4.10 Replacement of fieldbus adapter in the computer unit

Location

One of the following fieldbus adapters may be fitted in the slot in the computer unit as shown in the figure below:

- AnybusCC EtherNet/IP slave
- AnybusCC PROFIBUS slave
- AnybusCC PROFINET slave
- AnybusCC DeviceNet slave

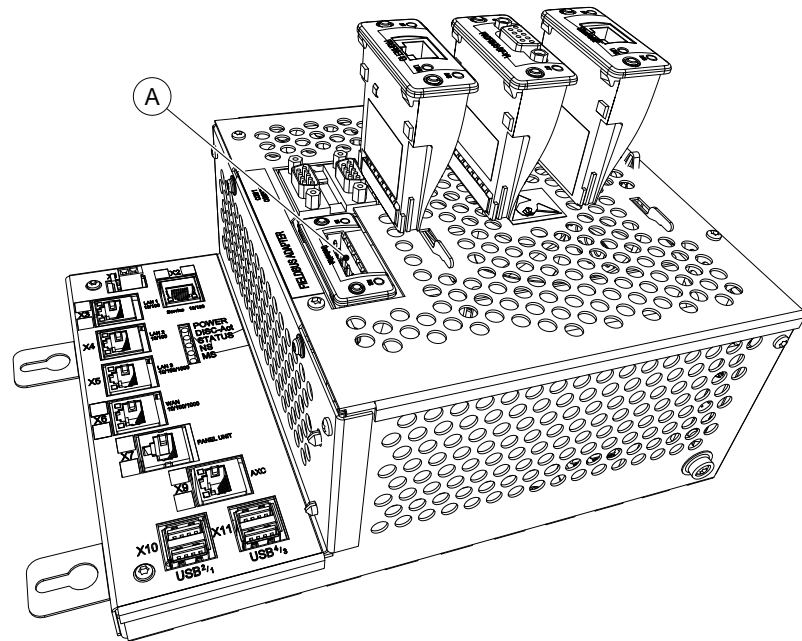

xx130000604

A	Slot for AnybusCC fieldbus adapters
---	-------------------------------------

Required equipment

Equipment	Art. no.	Note
AnybusCC EtherNet/IP slave fieldbus adapter	3HAC027652-001	DSQC 669 Ethernet/IP communication is described in <i>Application manual - EtherNet/IP Anybus Adapter</i>
AnybusCC PROFIBUS slave fieldbus adapter	3HAC026840-001	DSQC 667 PROFIBUS communication is described in <i>Application manual - PROFIBUS Anybus Device</i>
AnybusCC PROFINET slave fieldbus adapter	3HAC031670-001	DSQC 688 PROFINET communication is described in <i>Application manual - PROFINET Anybus Device</i>

Continues on next page

4 Repair

4.10 Replacement of fieldbus adapter in the computer unit

Continued



Equipment	Art. no.	Note
AnybusCC DeviceNet slave fieldbus adapter	3HAC045973-001	DSQC1004 DeviceNet communication is described in <i>Application manual - DeviceNet Anybus Slave</i> .
Standard toolkit		The contents are described in section <i>Standard toolkit, IRC5 on page 323</i> .

References

Equipment	Art. no.	Note
<i>Application manual - EtherNet/IP Anybus Adapter</i>	3HAC050997-001	Contains information on how to configure the system for EtherNet/IP Fieldbus Adapter DSQC 669.
<i>Application manual - PROFIBUS Anybus Device</i>	3HAC050965-001	Contains information on how to configure the system for PROFIBUS Fieldbus Adapter DSQC 667.
<i>Application manual - PROFINET Anybus Device</i>	3HAC050968-001	Contains information on how to configure the system for PROFINET Fieldbus Adapter DSQC 688.
<i>Application manual - DeviceNet Anybus Slave</i>	3HAC050993-001	Contains information on how to configure the system for DeviceNet Fieldbus Adapter DSQC1004.
Circuit diagram	See <i>Circuit diagrams on page 349</i> .	

Removal

The following procedure details how to remove the fieldbus adapter from the computer unit.

	Action	Note/Illustration
1	 DANGER Before doing any work inside the cabinet, disconnect the mains power. For more information, see <i>Electrical safety on page 37</i> .	
2	 ELECTROSTATIC DISCHARGE (ESD) The unit is sensitive to ESD. Before handling the unit read the safety information in section <i>The unit is sensitive to ESD on page 49</i> .	
3	Disconnect any cables to/from the fieldbus adapter.	

Continues on next page

4.10 Replacement of fieldbus adapter in the computer unit

Continued

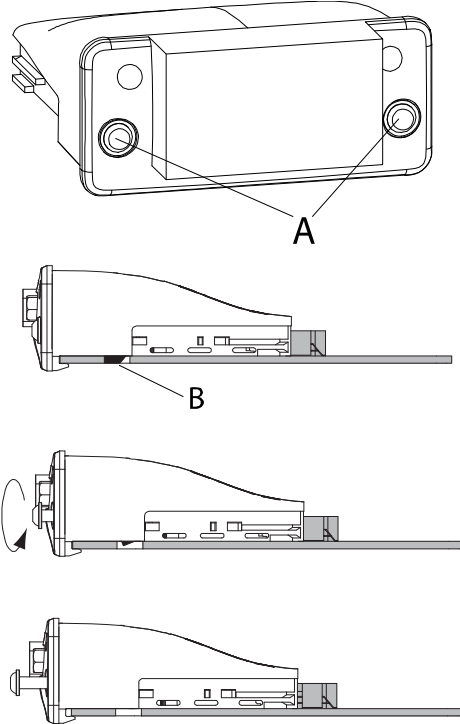
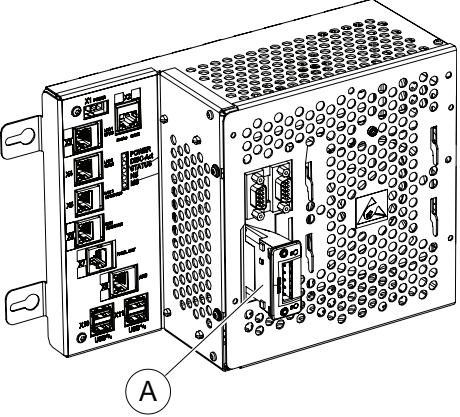
	Action	Note/Illustration
4	<p>Loosen the attachment screws (2 pcs) on front of the fieldbus adapter to release the fastening mechanism.</p> <p> Note</p> <p>Only loosen the attachment screws. Do not remove them.</p>	 <p>xx0700000193</p> <p>A Attachment screws (2 pcs) B Fastening mechanism</p>
5	<p>Grip the loosened attachment screws and gently pull the fieldbus adapter straight out.</p>	 <p>xx1500001755</p> <p>A Fieldbus adapter</p>

Continues on next page





4 Repair

4.10 Replacement of fieldbus adapter in the computer unit

Continued

Refitting

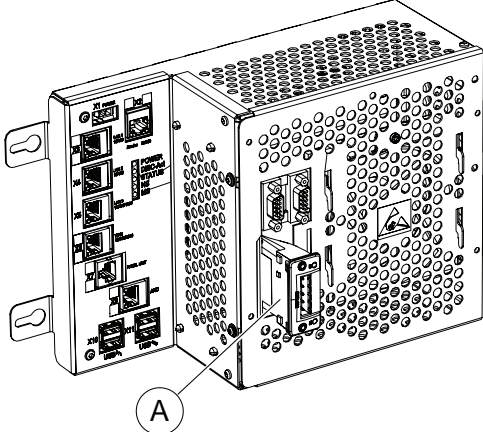
The following procedure details how to refit the fieldbus adapter in the computer unit.

	Action	Note/Illustrator
1	 DANGER Before doing any work inside the cabinet, disconnect the mains power. For more information, see Electrical safety on page 37 .	
2	 ELECTROSTATIC DISCHARGE (ESD) The unit is sensitive to ESD. Before handling the unit read the safety information in section The unit is sensitive to ESD on page 49 .	
3	 CAUTION Push carefully so no pins are damaged. Make sure that the adapter is pushed straight onto the rails.	 <p>xx1500001755</p> <p>A Fieldbus adapter</p>  CAUTION Always grip the fieldbus adapter around the edges to avoid damage to the adapter or its components.

Continues on next page

4.10 Replacement of fieldbus adapter in the computer unit

Continued

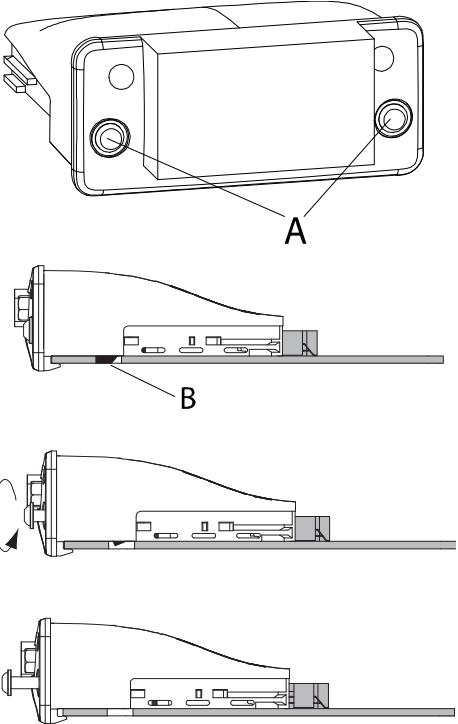
	Action	Note/Illustrator
4	Secure the fieldbus adapter with its attachment screws (2 pcs).	 <p data-bbox="954 1041 1061 1059">xx0700000193</p> <p data-bbox="991 1077 1321 1137"> A Attachment screws (2 pcs) B Fastening mechanism </p>
5	Reconnect the cable to the fieldbus adapter.	
6	Make sure the robot system is configured to reflect the fieldbus adapter installed.	
7	Perform the function tests in section Function tests on page 213 to verify that the safety features work properly.	

4 Repair

4.11 Replacement of fan in computer unit

4.11 Replacement of fan in computer unit

Location

The computer fan is located under the upper cover as shown in the figure below.

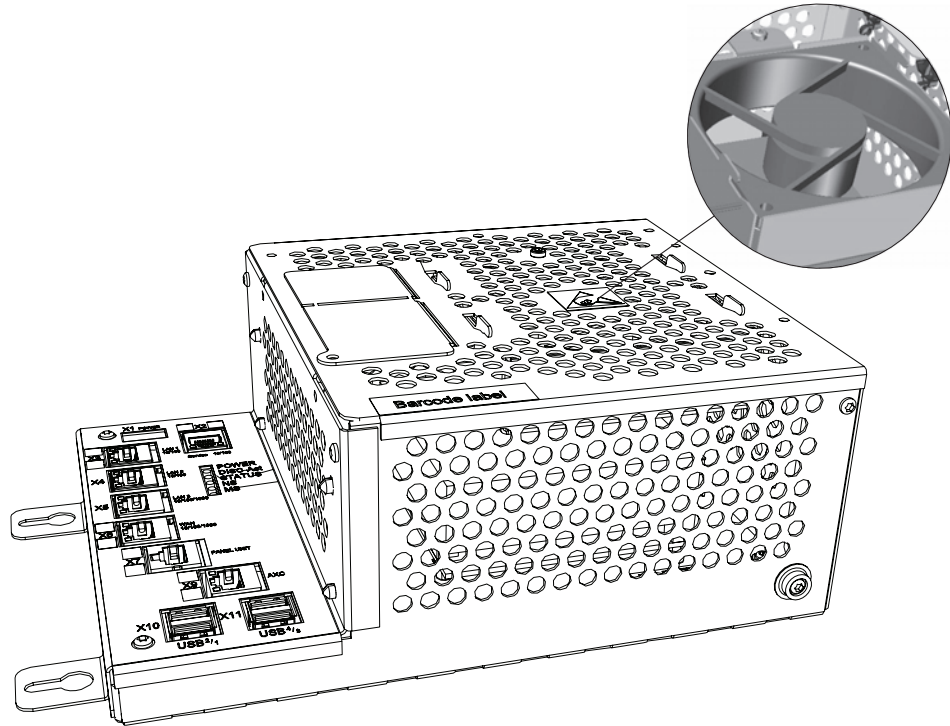

xx130000687

Required equipment



Equipment	Note
Fan	See Spare parts on page 327 .
Cable straps	
Standard toolkit	The contents are defined in section Standard toolkit.
Other tools and procedures may be required. See references to these procedures in the step-by-step instructions below.	These procedures include references to the tools required.
Circuit diagram	See Circuit diagrams on page 349 .

Removal

The procedure below details how to remove the fan in the computer unit.

Action	Note/Illustration
1  DANGER Before doing any work inside the cabinet, disconnect the mains power. For more information, see Electrical safety on page 37 .	

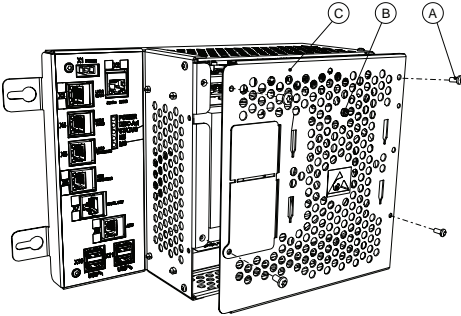
Continues on next page

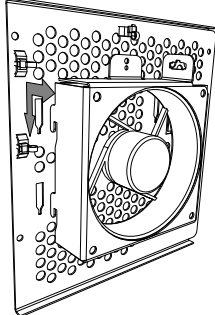
	Action	Note/Illustration
2	 ELECTROSTATIC DISCHARGE (ESD) The unit is sensitive to ESD. Before handling the unit read the safety information in section <i>The unit is sensitive to ESD on page 49</i> .	
3	Open the computer unit by removing the upper cover attachment screws and lift off the upper cover.	 <p>xx130000688</p> <p>A Upper cover attachment screws (4 pcs.) B Fan attachment screw C Upper cover</p>
4	Disconnect the fan connector and remove the cable straps.	 CAUTION Be careful with the fan cable when opening and removing the upper cover. The fan cable must not be stretched.
5	Remove the fan attachment screw.	
6	Remove the fan from the upper cover.	 <p>xx130000806</p>

Refitting

The procedure below details how to refit the fan in the computer unit.



	Action	Note/Illustration
1	 DANGER Before doing any work inside the cabinet, disconnect the mains power. For more information, see <i>Electrical safety on page 37</i> .	

Continues on next page

4 Repair

4.11 Replacement of fan in computer unit

Continued

	Action	Note/Illustration
2	 ELECTROSTATIC DISCHARGE (ESD) The unit is sensitive to ESD. Before handling the unit read the safety information in section <i>The unit is sensitive to ESD on page 49</i> .	
3	Refit the fan on the upper cover.	
4	Refit the attachment screw.	
5	Strap the fan cable to the upper cover.	 CAUTION When strapping the cable make sure that the cable is not stretched or squeezed, and that the cable does not get caught in the fan.
6	Refit the fan connector and close the computer unit.	 CAUTION Be careful with the fan cable when closing the upper cover. The fan cable must not be squeezed.
7	Perform the function tests in section <i>Function tests on page 213</i> to verify that the safety features work properly.	

4.12 Replacement of SD-card memory in computer unit

Location

The location and orientation of the SD-card memory is shown by the following illustration.

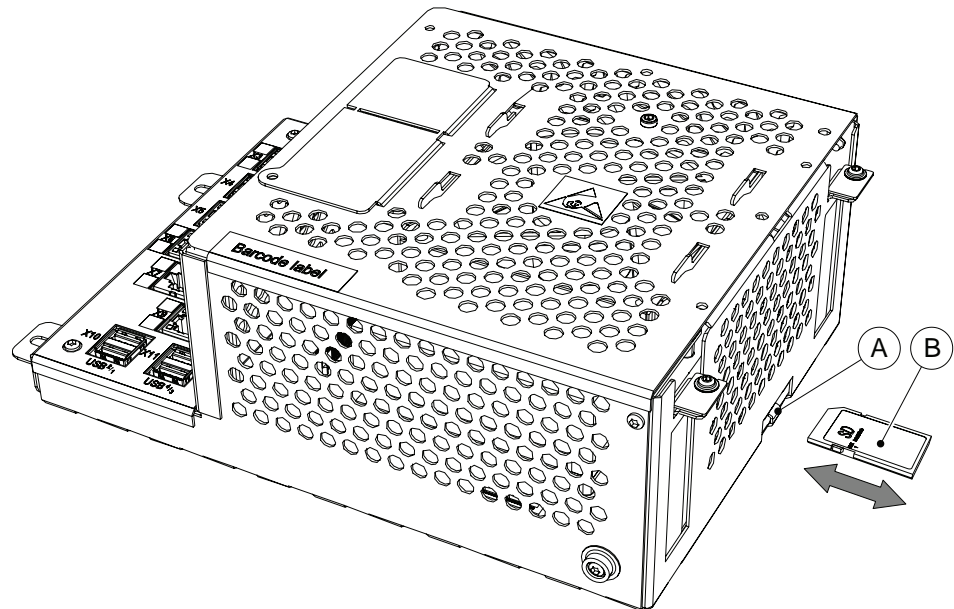

xx130000807

A	Slot for SD-card memory
B	SD-card memory



Note

Only use SD-card memory supplied by ABB.



Note

The SD-card from the computer unit DSQC1018 cannot be used in the computer unit DSQC1024/DSQC1094. Use the backup and restore function to move data from DSQC1018 to DSQC1024/DSQC1094.



CAUTION

Reformatting the SD-card or modifying the disk partition can cause irreparable boot-up problems.

Continues on next page

4 Repair

4.12 Replacement of SD-card memory in computer unit



Continued

Required equipment

Equipment	Note
SD-card 2GB	See Spare parts on page 327 .  Note Only use SD-card memory supplied by ABB. Includes <i>ABB Boot Application</i> software to correctly reboot the robot controller.
Standard toolkit	The content is described in section Standard toolkit, IRC5 on page 323 .



Removal

Use the following procedure to remove the SD-card memory.

	Action
1	 DANGER Before doing any work inside the cabinet, disconnect the mains power. For more information, see Electrical safety on page 37 .
2	 ELECTROSTATIC DISCHARGE (ESD) The unit is sensitive to ESD. Before handling the unit read the safety information in section The unit is sensitive to ESD on page 49 .
3	Gently push the SD-card memory with your finger until it clicks, and then pull it straight out.

Refitting

Use the following procedure to refit the SD-card memory.

	Action
1	 DANGER Before doing any work inside the cabinet, disconnect the mains power. For more information, see Electrical safety on page 37 .
2	 ELECTROSTATIC DISCHARGE (ESD) The unit is sensitive to ESD. Before handling the unit read the safety information in section The unit is sensitive to ESD on page 49 .
3	 CAUTION Make sure that the SD-card memory is correctly oriented before inserting it. Otherwise the SD-card memory or the SD-card memory slot may be damaged.

Continues on next page

4.12 Replacement of SD-card memory in computer unit

Continued

	Action
4	Gently push the SD-card memory with your finger until it clicks into place.
5	Perform the function tests in section Function tests on page 213 to verify that the safety features work properly.

4 Repair

4.13 Replacement of drive units

4.13 Replacement of drive units

Location

The illustration shows the location of drive units in the controller.

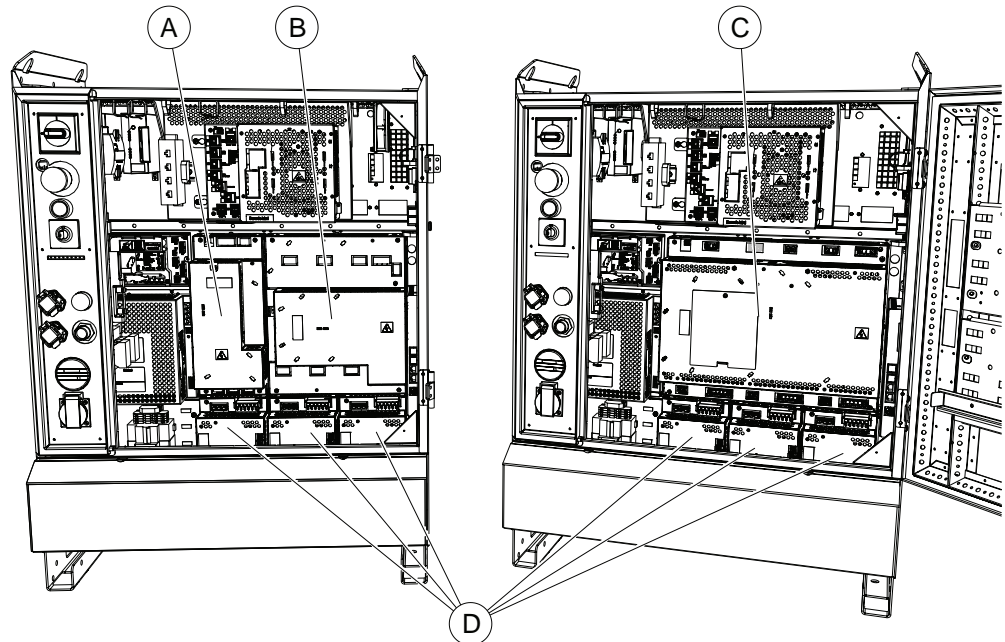

xx130000808

A	Additional Rectifier Unit (only used for additional axes in combination with small robots)
B	Main Drive Unit for small robots
C	Main Drive Unit for large robots
D	Additional Drive Units (for additional axes)

Configuration

The drive units exist in a number of versions, these are described in section [Configuration of the drive system on page 118](#).

Required equipment

Equipment	Note
Drive units	Specified in section Configuration of the drive system on page 118 .
Standard toolkit	The contents are defined in section Standard toolkit, IRC5 on page 323 .
Other tools and procedures may be required. See references to these procedures in the step-by-step instructions below.	These procedures include references to the tools required.
Circuit diagram	See Circuit diagrams on page 349 .

Continues on next page

Removal

The procedure below describes how to remove the Main Drive Unit and the Additional Drive Units. If your drive system contains an Additional Rectifier Unit, it is replaced in a similar way.

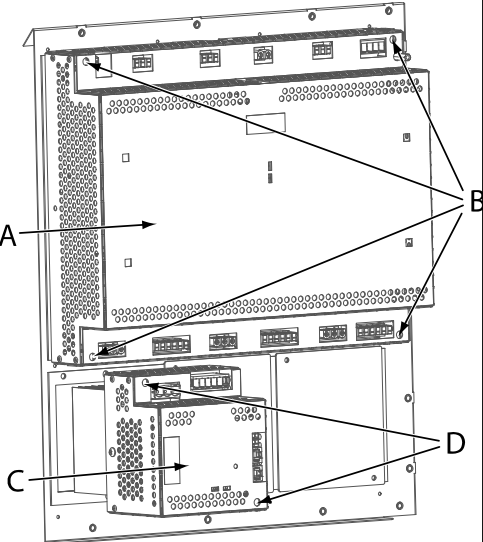
	Action	Note/Illustration
1	<p> DANGER</p> <p>Before doing any work inside the cabinet, disconnect the mains power. For more information, see Electrical safety on page 37.</p>	
2	<p>If an EPS or SafeMove board (option <i>Electronic Position Switches</i> or <i>SafeMove</i>) is mounted, the Axis computer unit must be removed before removal of the Main Drive Unit.</p>	<p>See Replacement of EPS board DSQC 646 for Electronic Position Switches on page 267 or Replacement of SafeMove board DSQC 647 on page 271.</p>
3	<p>Disconnect all connectors from the unit to be replaced.</p>	
4	<p>Remove the drive unit after unscrewing its attachment screws.</p>	 <p>xx0900000025</p> <p>Parts:</p> <ul style="list-style-type: none"> • A: Main Drive Unit • B: Attachment screws for MDU • C: Additional Drive Unit • D: Attachment screws for ADU

Continues on next page



4 Repair

4.13 Replacement of drive units

Continued

Refitting

The procedure below describes how to refit the drive units.

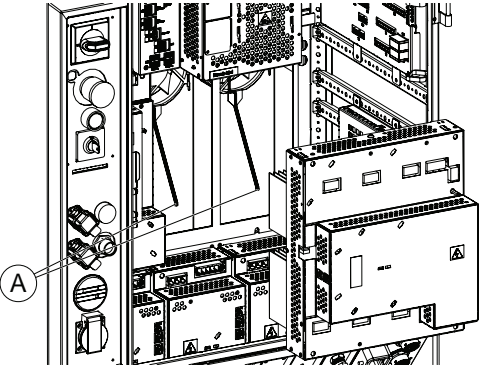
	Action	Note/Illustration
1	<p> DANGER</p> <p>Before doing any work inside the cabinet, disconnect the mains power. For more information, see Electrical safety on page 37.</p>	
	<p> CAUTION</p> <p>If the controller is equipped with temperature sensor controlled fans, remove the sensors before fitting an MDU. See Replacement of sensors for the drive system fans on page 287.</p> <p>If the MDU is fitted with the sensors still in place at the back wall of the cabinet, the sensor holders will be bent and the sensors will measure the temperature in the wrong place. This will result in too high temperature in the controller cabinet and shorter life time for the components.</p>	 <p>xx150000859</p> <p>A Temperature sensors</p>
2	Fit the unit in its intended position and orientation. Secure it with its <i>attachment screws</i> .	
3	Reconnect any connectors disconnected at removal.	
4	Refit the Axis computer unit if it was removed before the drive unit was removed.	
5	Perform the function tests in section Function tests on page 213 to verify that the safety features work properly.	

4.14 Replacement of Axis computer

Location

The illustration below shows the location of the axis computer in the controller.

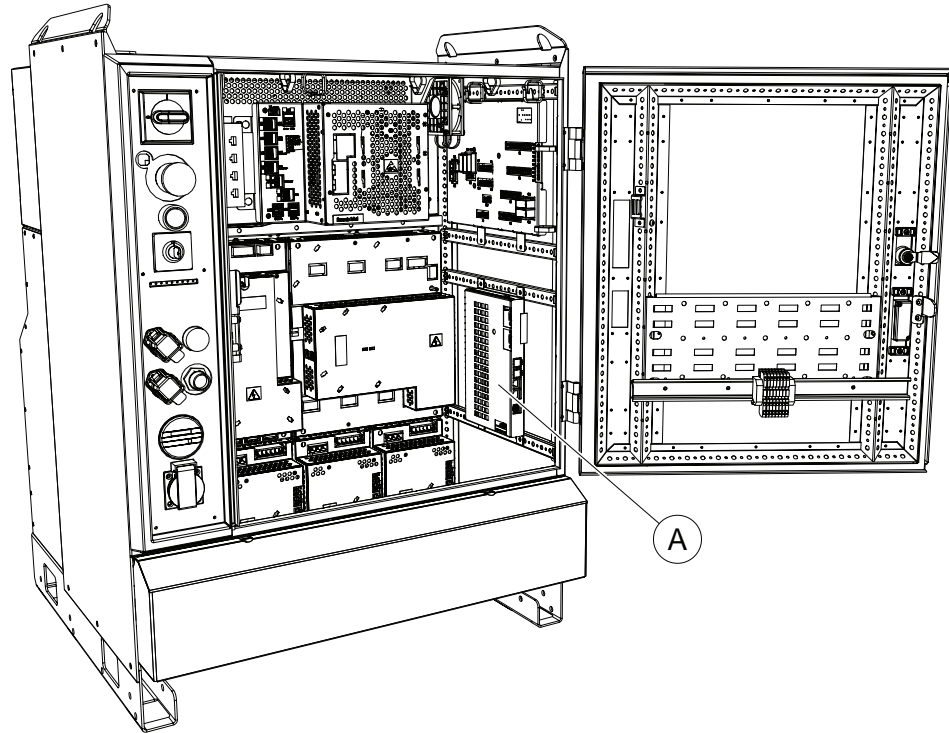



xx130000809

A	Axis computer
---	---------------

Removal

The procedure below details how to remove the axis computer.

	Action	Note/Illustration
1	 DANGER Before doing any work inside the cabinet, disconnect the mains power. For more information, see Electrical safety on page 37 .	
2	 ELECTROSTATIC DISCHARGE (ESD) The unit is sensitive to ESD. Before handling the unit read the safety information in section The unit is sensitive to ESD on page 49 .	
3	Disconnect all connectors from the axis computer.	 Tip Make a note of the connections.

Continues on next page

4 Repair

4.14 Replacement of Axis computer

Continued

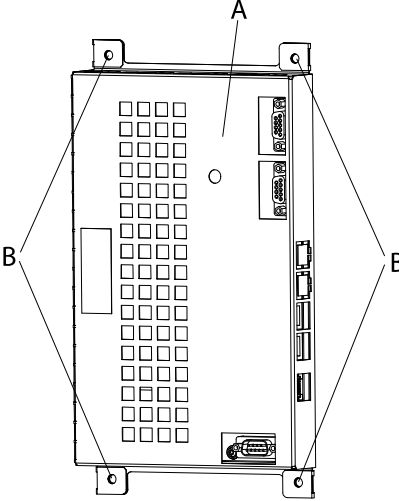
	Action	Note/Illustration
4	Remove the attachment screws.	 <p>xx0900000030</p> <ul style="list-style-type: none"> • A: axis computer • B: attachment screws
5	Remove the axis computer.	

Refitting

The procedure below details how to refit the axis computer.

	Action
1	 <p>DANGER</p> <p>Before doing any work inside the cabinet, disconnect the mains power. For more information, see Electrical safety on page 37.</p>
2	Fit the new axis computer.
3	Refit the attachment screws.
4	Reconnect all the connectors.
5	Perform the function tests in section Function tests on page 213 to verify that the safety features work properly.

4.15 Replacement of EPS board DSQC 646 for Electronic Position Switches

General

An Electronic Position Switches safety controller, EPS board, is mounted if the option Electronic Position Switches is used.



Note

After replacement of the safety controller, the Electronic Position Switches configuration must be downloaded to the new safety controller and then validated. For more information, see *Application manual - Electronic Position Switches*.

Location

The EPS board is mounted behind the axis computer.

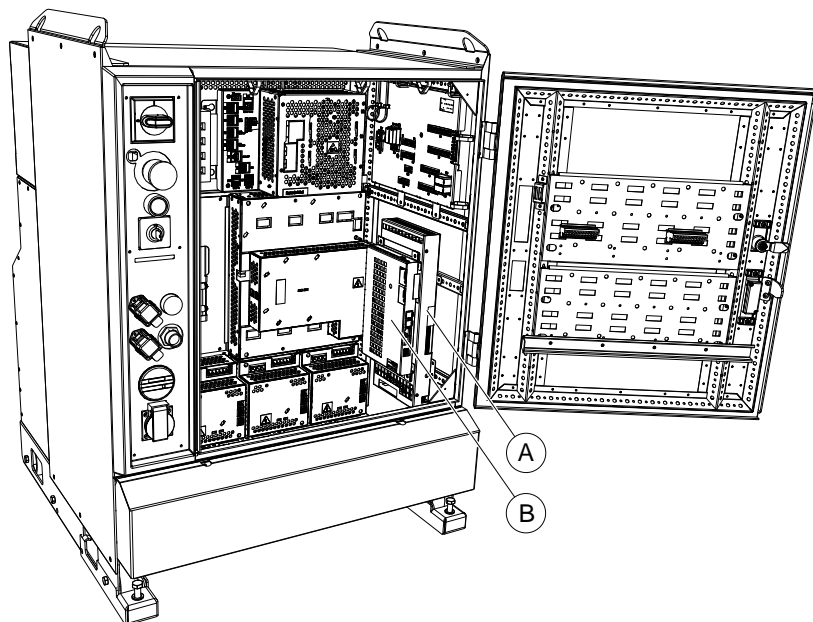

xx130000810

A	EPS board
B	Axis computer

Removal

	Action	Note/illustration
1	 DANGER Before doing any work inside the cabinet, disconnect the mains power. For more information, see Electrical safety on page 37 .	

Continues on next page

4 Repair

4.15 Replacement of EPS board DSQC 646 for Electronic Position Switches

Continued

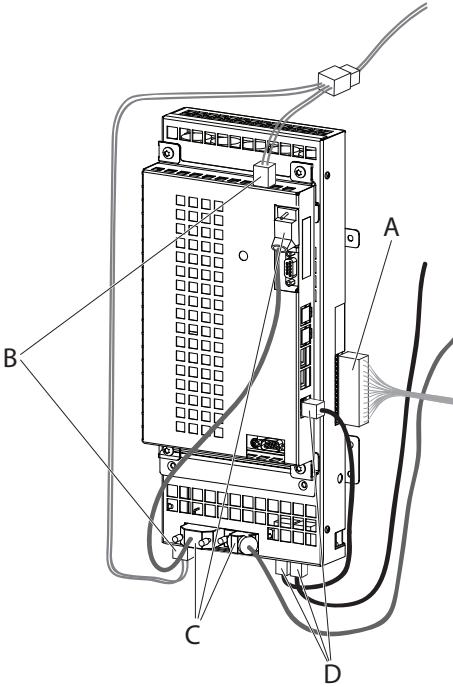
	Action	Note/illustration
2	<p> ELECTROSTATIC DISCHARGE (ESD)</p> <p>The unit is sensitive to ESD. Before handling the unit read the safety information in section <i>The unit is sensitive to ESD on page 49.</i></p>	
3	<p>Disconnect the following cables connected to the EPS board and axis computer:</p> <ul style="list-style-type: none">• Plug contact in I/O connector• Power cables• SMB cables• Ethernet cables	 <p>xx0700000101</p> <p>A: Plug contact in I/O connector B: Power cables C: SMB cables D: Ethernet cables</p>

Continues on next page

4.15 Replacement of EPS board DSQC 646 for Electronic Position Switches
Continued

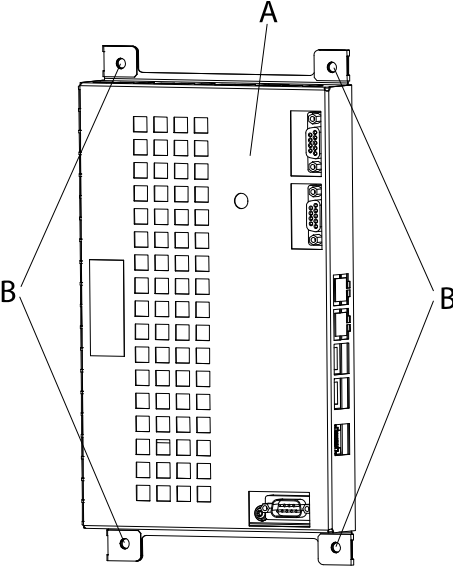
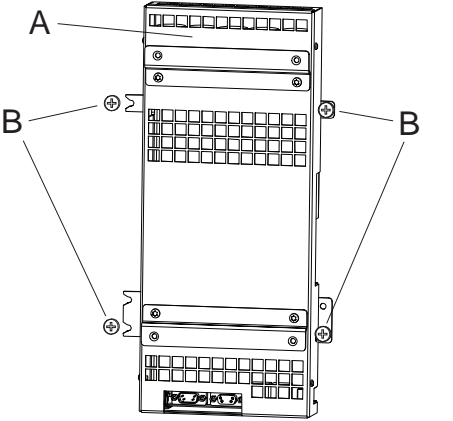
	Action	Note/illustration
4	Remove the attachment screws of the axis computer and remove the axis computer.	 <p>xx0900000030</p> <ul style="list-style-type: none"> • A: axis computer • B: attachment screws
5	Remove the attachment screws of the EPS board and remove the EPS board.	 <p>xx0600003204</p> <ul style="list-style-type: none"> • A: EPS board • B: attachment screws

Refitting

	Action	Note/illustration
1	 <p>DANGER</p> <p>Before doing any work inside the cabinet, disconnect the mains power. For more information, see Electrical safety on page 37.</p>	

Continues on next page

4 Repair

4.15 Replacement of EPS board DSQC 646 for Electronic Position Switches

Continued

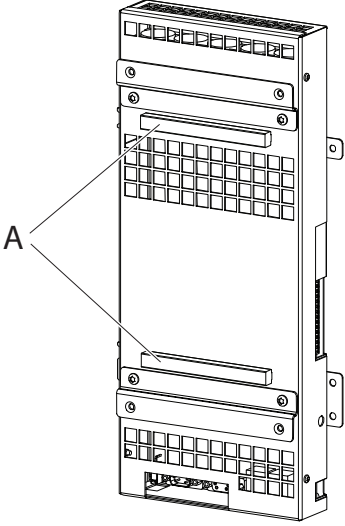
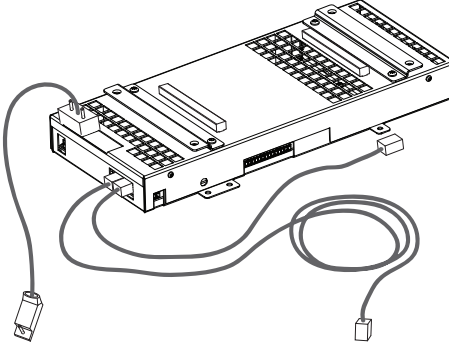
	Action	Note/illustration
2	 <p>ELECTROSTATIC DISCHARGE (ESD)</p> <p>The unit is sensitive to ESD. Before handling the unit read the safety information in section The unit is sensitive to ESD on page 49.</p>	
3	<p>If not already in place, fit the EMC strips on the EPS board.</p>	 <p>xx070000087</p>
4	<p>Connect the short SMB cable and both Ethernet cables to the EPS board before mounting the board. These connections may be difficult to reach once the board is mounted.</p> <p>The two Ethernet connectors on the EPS board are interchangeable (it does not matter which is connected to the main computer and which is connected to the axis computer).</p>	 <p>xx0600003303</p>
5	<p>Refit the EPS board and the axis computer.</p>	
6	<p>Refit all the cables.</p>	
7	<p>After replacement of the safety controller, the EPS configuration must be downloaded to the new safety controller and then validated. For more information, see <i>Application manual - Electronic Position Switches</i>.</p>	
8	<p>Perform the function tests in section Function tests on page 213 to verify that the basic safety features (e.g. emergency stop) work properly.</p>	

4.16 Replacement of SafeMove board DSQC 647

General

A SafeMove safety controller, SafeMove board, is mounted if the option SafeMove is used.



Note

After replacement of the safety controller, the SafeMove configuration must be downloaded to the new safety controller and then validated. For more information, see *Application manual - SafeMove1*.

Location

The SafeMove board is mounted behind the axis computer.

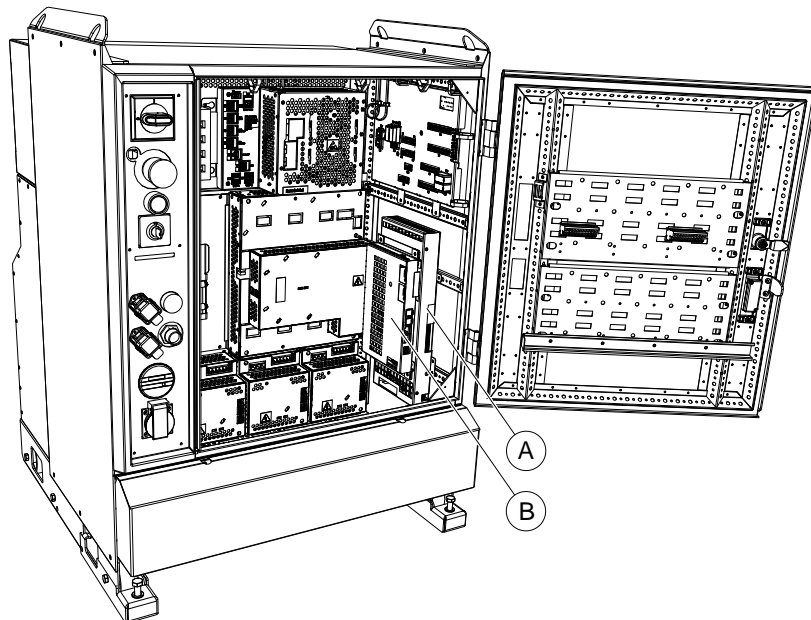

xx130000810

A	SafeMove board
B	Axis computer

Removal

The procedure below details how to remove the SafeMove board.

	Action	Note/illustration
1	 DANGER Before doing any work inside the cabinet, disconnect the mains power. For more information, see Electrical safety on page 37 .	

Continues on next page

4 Repair

4.16 Replacement of SafeMove board DSQC 647

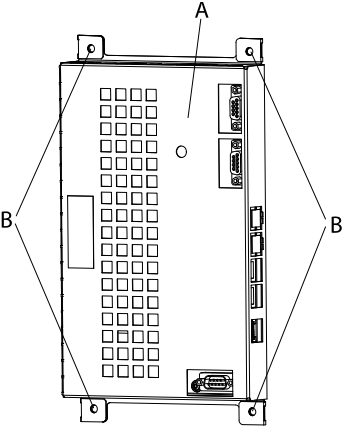
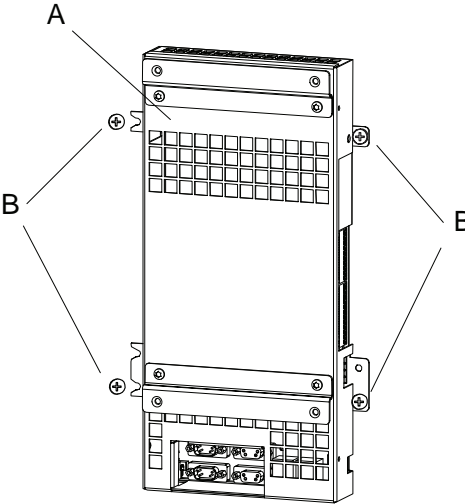

Continued

	Action	Note/illustration
2	 <p>ELECTROSTATIC DISCHARGE (ESD)</p> <p>The unit is sensitive to ESD. Before handling the unit read the safety information in section <i>The unit is sensitive to ESD on page 49.</i></p>	
3	<p>Disconnect the cables connected to the SafeMove board and the cables between the SafeMove board and the axis computer.</p>	
4	<p>Remove the attachment screws of the axis computer and remove the axis computer.</p>	 <p>xx0900000030</p> <ul style="list-style-type: none"> • A: axis computer • B: attachment screws (4 pcs)
5	<p>Remove the attachment screws of the SafeMove board and remove the SafeMove board.</p>	 <p>xx0800000104</p> <ul style="list-style-type: none"> • A: SafeMove board • B: attachment screws (4 pcs)

Continues on next page

Refitting

The procedure below details how to refit the SafeMove board.

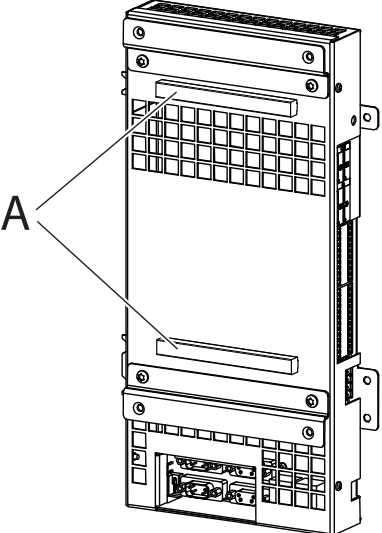
	Action	Note/illustration
1	 <p>DANGER</p> <p>Before doing any work inside the cabinet, disconnect the mains power. For more information, see Electrical safety on page 37.</p>	
2	 <p>ELECTROSTATIC DISCHARGE (ESD)</p> <p>The unit is sensitive to ESD. Before handling the unit read the safety information in section The unit is sensitive to ESD on page 49.</p>	
3	<p>If not already in place, fit the EMC strips on the SafeMove board.</p>	 <p>xx0800000204</p> <ul style="list-style-type: none"> A: EMC strips

Continues on next page

4 Repair

4.16 Replacement of SafeMove board DSQC 647

Continued

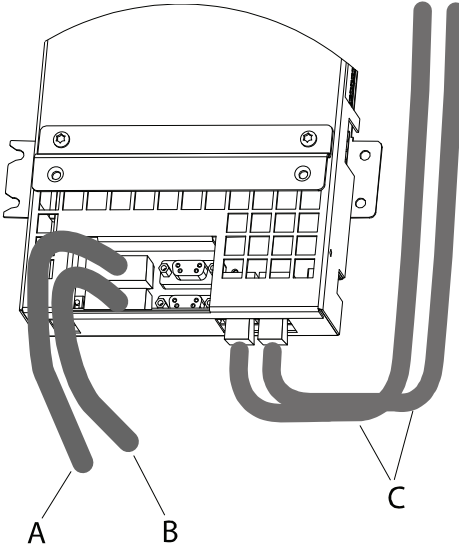
	Action	Note/illustration
4	<p>Connect both SMB cables and both Ethernet cables to the SafeMove board before mounting the board. These connections may be difficult to reach once the board is mounted.</p> <p>The two Ethernet connectors on the SafeMove board are interchangeable (it does not matter which is connected to the main computer and which is connected to the axis computer).</p>	 <p>xx0800000103</p> <ul style="list-style-type: none">• A: SMB1 cable• B: SMB2 cable• C: Ethernet cables
5	Refit the SafeMove board and the axis computer.	
6	Refit all cables.	
7	After replacement of the safety controller, the SafeMove configuration must be downloaded to the new safety controller and then validated. For more information, see <i>Application manual - SafeMove1</i> .	
8	Perform the function tests in section Function tests on page 213 to verify that the basic safety features (e.g. emergency stop) work properly.	

4.17 Replacement of Safety module DSQC1015 for SafeMove

Location

The Safety module DSQC1015 is a PCIeexpress board that is located inside the IRC5 main computer unit.

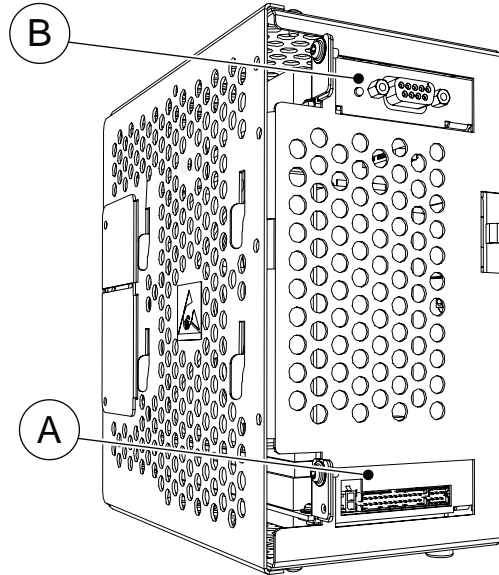

xx1500001760

A	Safety module DSQC1015
B	PCIexpress slot for other devices.

Required equipment

Equipment	Note
DSQC1015 Safety module	3HAC048858-001
Standard toolkit	The contents are defined in section Standard toolkit, IRC5 on page 323 .
Circuit diagram	See Circuit diagrams on page 349 .

Removing the Safety module





	Action	Note/Illustration
1	 DANGER Before doing any work inside the cabinet, disconnect the mains power. For more information, see Electrical safety on page 37 .	

Continues on next page

4 Repair

4.17 Replacement of Safety module DSQC1015 for SafeMove

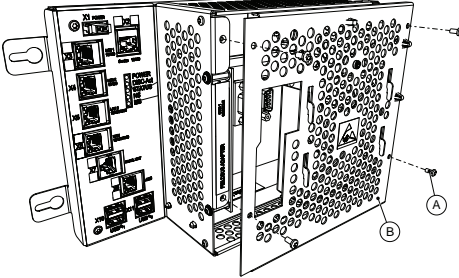
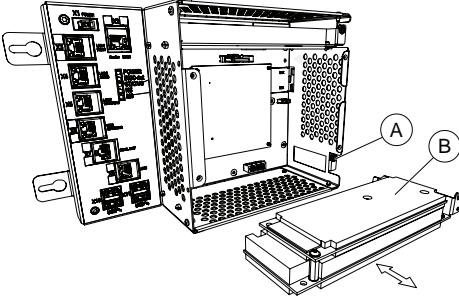
Continued



	Action	Note/Illustration
2	 <p>ELECTROSTATIC DISCHARGE (ESD)</p> <p>The unit is sensitive to ESD. Before handling the unit read the safety information in section <i>The unit is sensitive to ESD on page 49</i>.</p>	
3	<p>Open the computer unit by removing the attachment screws and lift off the cover. Disconnect the fan connector.</p> <p> CAUTION</p> <p>Be careful with the fan cable when opening and removing the upper cover. The fan cable must not be stretched.</p>	 <p>xx1300000684</p> <p>A Attachment screws (4 pcs.) B Cover</p>
4	<p>Remove the attachment screw on top of the slot bracket.</p>	
5	<p>Remove the Safety module by pulling it out of the socket on the motherboard.</p>	 <p>xx1500001761</p> <p>A Attachment screw B Safety module</p> <p> CAUTION</p> <p>Always grip the board around the edges to avoid damage to the board or its components.</p>

Refitting the Safety module

	Action	Note/Illustration
1	<p> DANGER</p> <p>Before doing any work inside the cabinet, disconnect the mains power. For more information, see <i>Electrical safety on page 37</i>.</p>	

Continues on next page

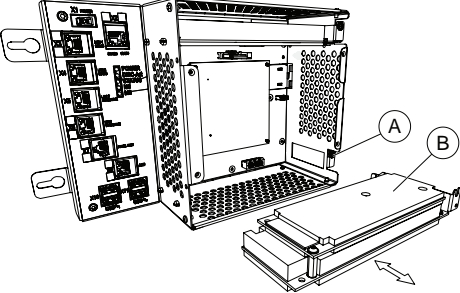
4.17 Replacement of Safety module DSQC1015 for SafeMove
Continued

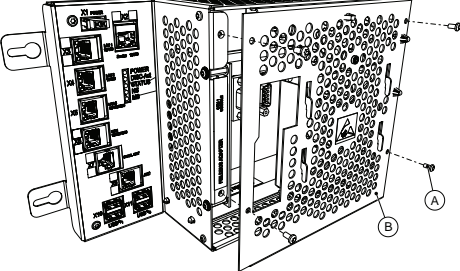
	Action	Note/Illustration
2	 <p>ELECTROSTATIC DISCHARGE (ESD)</p> <p>The unit is sensitive to ESD. Before handling the unit read the safety information in section <i>The unit is sensitive to ESD on page 49.</i></p>	
3	<p>Fit the Safety module in position by pushing it into the socket on the motherboard.</p>	 <p>xx1500001761</p> <p>A Attachment screw B Safety module</p>  <p>CAUTION</p> <p>Always grip the board around the edges to avoid damage to the board or its components.</p>
4	<p>Refit the attachment screw on top of the Safety module bracket.</p>	
5	 <p>CAUTION</p> <p>Be careful with the fan cable when closing the cover. The fan cable must not be squeezed.</p>	 <p>xx130000684</p> <p>A Attachment screws (4 pcs.) B Cover</p>
6	<p>Perform the function tests in section <i>Function tests on page 213</i> to verify that the basic safety features (e.g. emergency stop) work properly.</p>	
7	<p>Perform a synchronization.</p>	<p>See <i>Application manual - Functional safety and SafeMove2.</i></p>
8	<p>Perform a Cyclic Brake Check.</p>	<p>See <i>Application manual - Functional safety and SafeMove2.</i></p>
9	<p>Lock the SafeMove configuration file.</p>	<p>See <i>Application manual - Functional safety and SafeMove2.</i></p>

4 Repair

4.18 Replacement of Remote Service box

4.18 Replacement of Remote Service box

General

A Remote Service box is mounted in the controller if the option Remote Service is used.

Location

The illustration below shows the Remote Service box in the controller.

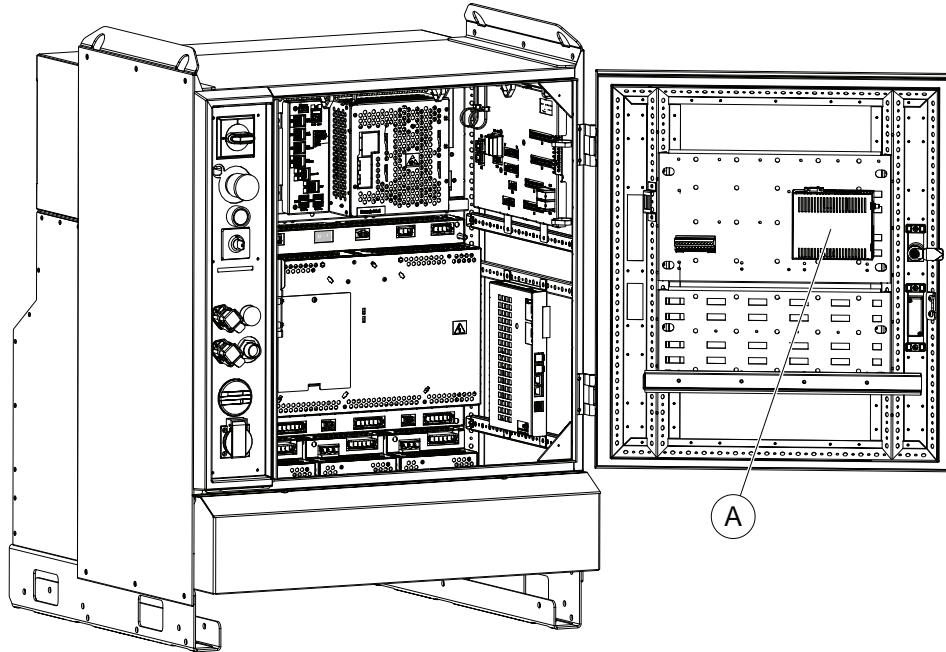

xx130000811

A	Remote Service box
---	--------------------



Required equipment

Equipment	Note
Remote Service box	DSQC 680 See Spare parts on page 327 .
Standard toolkit	The contents are defined in section Standard toolkit.
Other tools and procedures may be required. See references to these procedures in the step-by-step instructions below.	
Circuit diagram	See Circuit diagrams on page 349 .

Continues on next page

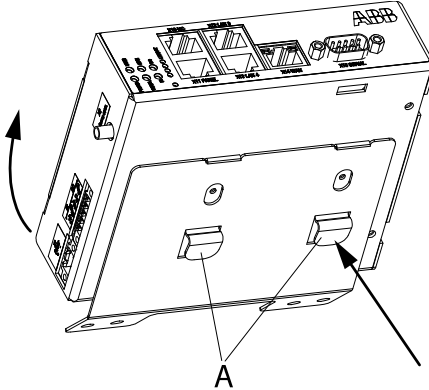

Removal

Use this procedure to remove the Remote Service box.

	Action	Note/illustration
1	 <p>DANGER</p> <p>Before doing any work inside the cabinet, disconnect the mains power. For more information, see Electrical safety on page 37.</p>	
2	 <p>ELECTROSTATIC DISCHARGE (ESD)</p> <p>The unit is sensitive to ESD. Before handling the unit read the safety information in section The unit is sensitive to ESD on page 49.</p>	
3	<p>Disconnect all connectors from the Remote Service box.</p>	
4	<p>Push the spring locks in the arrow direction and lift the box out.</p>	 <p>xx0800000091</p> <ul style="list-style-type: none"> A: Spring lock

Refitting

Use this procedure to refit the Remote Service box.

	Action	Note/illustration
1	 <p>DANGER</p> <p>Before doing any work inside the cabinet, disconnect the mains power. For more information, see Electrical safety on page 37.</p>	
2	 <p>ELECTROSTATIC DISCHARGE (ESD)</p> <p>The unit is sensitive to ESD. Before handling the unit read the safety information in section The unit is sensitive to ESD on page 49.</p>	

Continues on next page

4 Repair

4.18 Replacement of Remote Service box

Continued

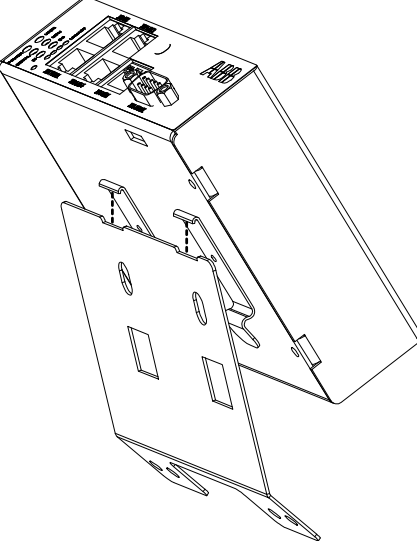
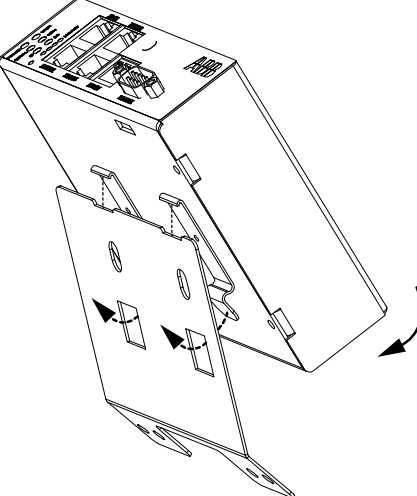
	Action	Note/illustration
3	Fit the Remote Service box in position.	 <p>xx080000092</p>
4	Push the Remote Service box in the arrow direction until the spring locks snaps into position.	 <p>xx080000093</p>
5	Reconnect all connectors to the Remote Service box.	
6	Perform the function tests in section Function tests on page 213 to verify that the safety features work properly.	

4.19 Replacement of Contactor Interface Board

Location

The illustration below shows the location of the contactor interface board in the controller.

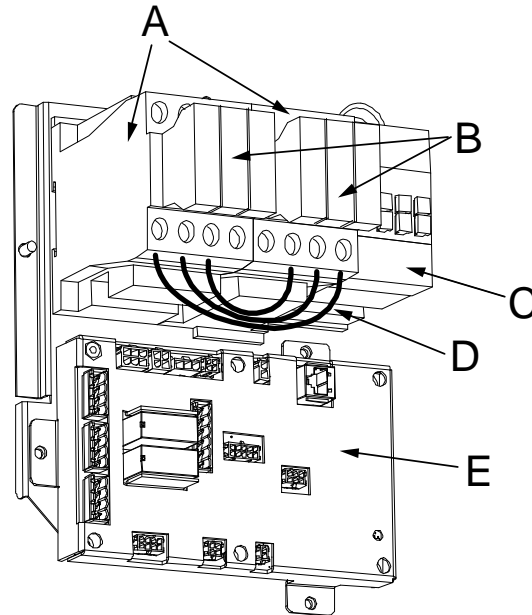

xx0400001058

A	MOTOR ON contactor K42
B	MOTOR ON contactor K43
C	Brake contactor
D	Jumpers (3pcs)
E	Contactor interface board

Required equipment

Equipment	Note
Contactor Interface board	DSQC 611 See Spare parts on page 327 .
Standard toolkit	The contents are defined in section Standard toolkit.
Other tools and procedures may be required. See references to these procedures in the step-by-step instructions below.	These procedures include references to the tools required.
Circuit diagram	See Circuit diagrams on page 349 .

Continues on next page



4 Repair

4.19 Replacement of Contactor Interface Board

Continued

Removal

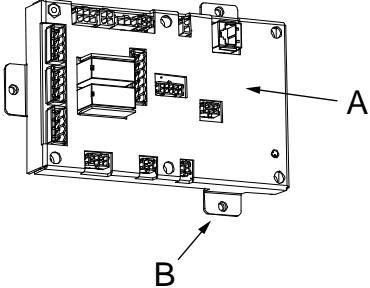
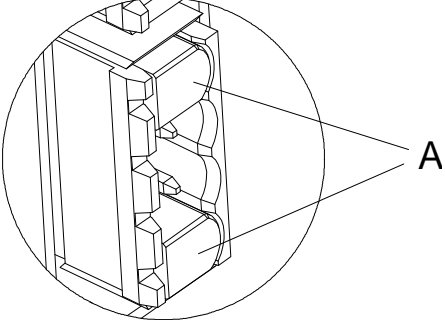

The procedure below details how to remove the contactor board.

	Action	Note/Illustration
1	 DANGER Before doing any work inside the cabinet, disconnect the mains power. For more information, see Electrical safety on page 37 .	
2	 ELECTROSTATIC DISCHARGE (ESD) The unit is sensitive to ESD. Before handling the unit read the safety information in section The unit is sensitive to ESD on page 49 .	
3	Disconnect all connectors.	 Tip Make a note of any connections.
4	Remove the attachment screws.	 <p>xx0400001062</p> <ul style="list-style-type: none"> A: contactor interface board B: attachment screws
5	Remove the contactor interface board.	
6	If SafeMove option is used, the plugs in the limit switch override contact (X23) pin 1 and 4, must be moved to the new contactor interface board. Use a small flat pliers to remove the plugs.	 <p>xx0800000035</p> <ul style="list-style-type: none"> A: plug (2 pcs)

Continues on next page

Refitting

The procedure below details how to refit the contactor board.

	Action	Note/Illustration
1	 DANGER Before doing any work inside the cabinet, disconnect the mains power. For more information, see Electrical safety on page 37 .	
2	 ELECTROSTATIC DISCHARGE (ESD) The unit is sensitive to ESD. Before handling the unit read the safety information in section The unit is sensitive to ESD on page 49 .	
3	If SafeMove is used, mount the plugs in the limit switch override contact (X23) pin 1 and 4.	 Note The limit switch override contact must be plugged and not used when using SafeMove.
4	Refit the contactor interface board.	
5	Refit the attachment screws.	
6	Reconnect all connectors.	
7	Perform the function tests in section Function tests on page 213 to verify that the safety features work properly.	

4 Repair

4.20 Replacement of drive system fans

4.20 Replacement of drive system fans

Location

The illustration below shows the location of the fan unit in the controller.

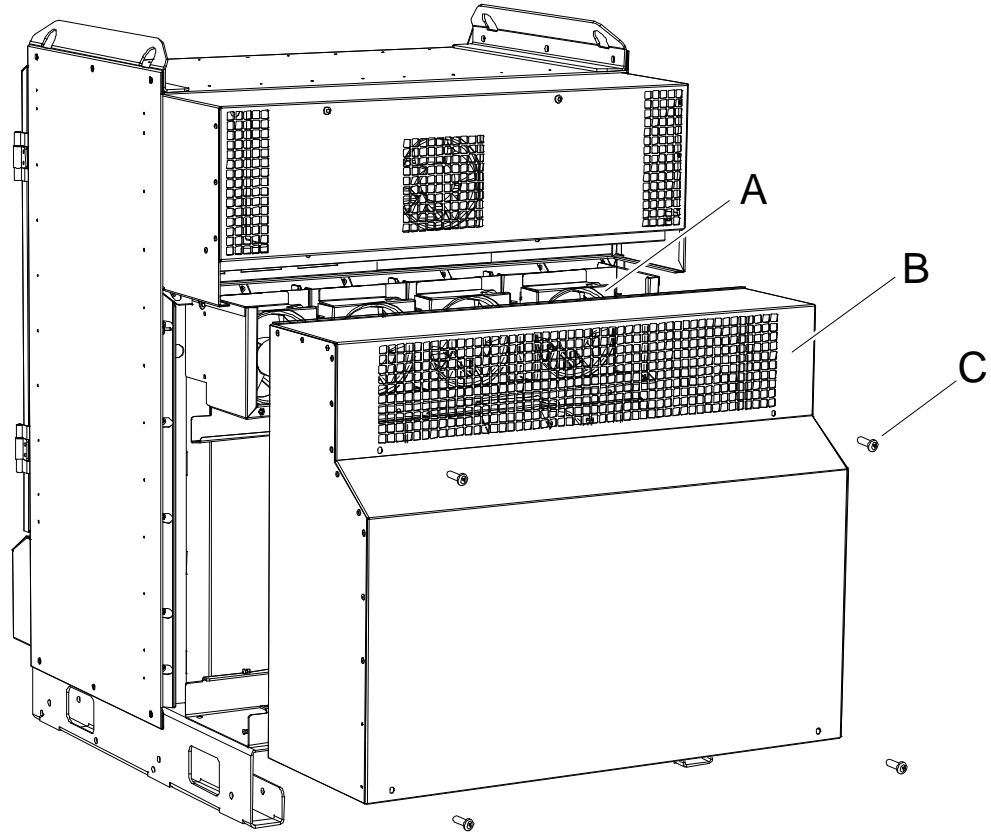

xx0500002011

A	Fan (4 pcs)
B	Cover
C	Attachment screw (4 pcs)

Required equipment

Equipment	Note
Fan	See Spare parts on page 327 .
Standard toolkit	The contents are defined in section Standard toolkit.
Other tools and procedures may be required. see references to these procedures in the step-by-step instructions below.	These procedures include references to the tools required.
Circuit diagram	See Circuit diagrams on page 349 .

Continues on next page

Removal

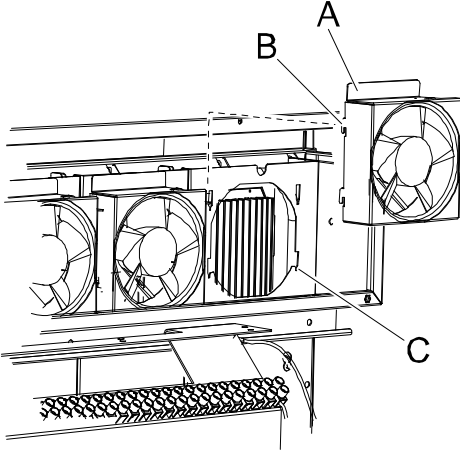
	Action	Note /illustration
1	 DANGER Before doing any work inside the cabinet, disconnect the mains power. For more information, see Electrical safety on page 37 .	
2	Remove the moist dust filter magazine. (Option)	How to remove the moist dust filter magazine is detailed in section Replacement of moist dust filter on page 205 .
3	Loosen the four attachment screws to the cover.	
4	Remove the cover.	
5	Disconnect the connector to the fan.	
6	If the fan is temperature sensor controlled, disconnect the sensor as described in Replacement of sensors for the drive system fans on page 287 .	
7	Push the fan upwards and remove it.	 <p>xx0500002015</p> <p>A Fan B Latches C Grooves</p>

Refitting

	Action	Note/illustration
1	 DANGER Before doing any work inside the cabinet, disconnect the mains power. For more information, see Electrical safety on page 37 .	
2	If the fan is temperature sensor controlled, fit the sensor and connect it as described in Replacement of sensors for the drive system fans on page 287 .	

Continues on next page

4 Repair

4.20 Replacement of drive system fans

Continued

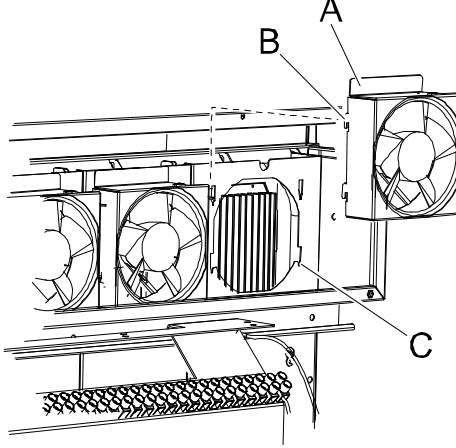
	Action	Note/illustration
3	Reconnect the connector to the fan.	
4	Refit the fan by placing the latches in the back of the fan housing in the grooves.	 <p data-bbox="946 817 1053 840">xx0500002015</p> <p data-bbox="978 853 1114 954">A Fan B Latches C Grooves</p>
5	Refit the cover and the attachment screws.	
6	Refit the moist dust filter magazine. (Option)	
7	Perform the function tests in section Function tests on page 213 to verify that the safety features work properly.	

4.21 Replacement of sensors for the drive system fans

Location

The illustration below shows the location of the drive system fan unit in the controller.

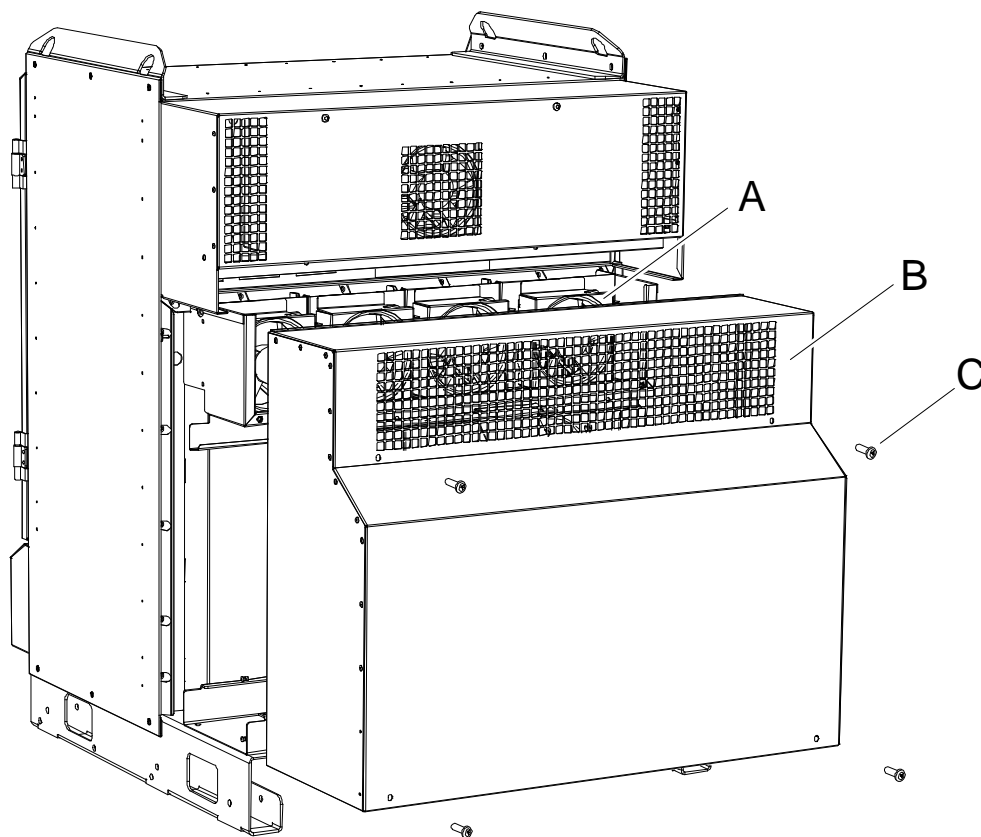

xx0500002011

A	Fan (up to 4 pcs)
B	Cover
C	Attachment screw (4 pcs)

Required equipment

Equipment	Note
Temp sensor for drive system fans	See Spare parts on page 327 .
Standard toolkit	The contents are defined in section Standard toolkit.
Other tools and procedures may be required. See references to these procedures in the step-by-step instructions below.	These procedures include references to the tools required.
Circuit diagram	See Circuit diagrams on page 349 .

Continues on next page

4 Repair

4.21 Replacement of sensors for the drive system fans

Continued

Removal

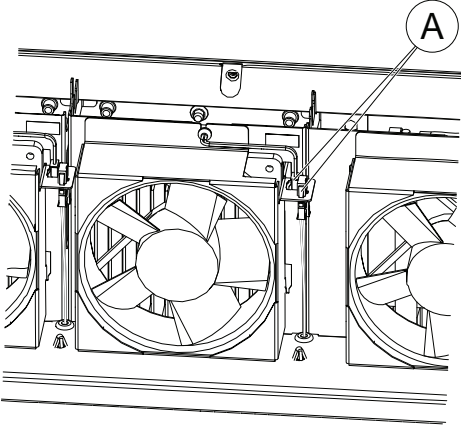
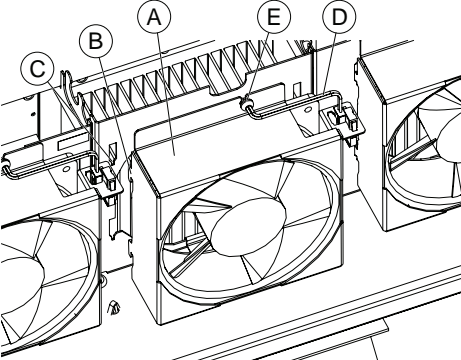
	Action	Note /illustration
1	 <p>DANGER</p> <p>Before doing any work inside the cabinet, disconnect the mains power. For more information, see Electrical safety on page 37.</p>	
2	Remove the moist dust filter magazine. (Option)	How to remove the moist dust filter magazine is detailed in section Replacement of moist dust filter on page 205 .
3	Loosen the four attachment screws to the cover.	
4	Remove the cover.	
5	Disconnect the connectors to the fan.	 <p>xx150000855</p> <p>A Connectors</p>
6	Slide the cable gland out of the indentation.	 <p>xx150000856</p> <p>A Fan B Latches C Grooves D Temp sensor cable E Cable gland</p>
7	Push the fan upwards and remove it.	

Continues on next page

4.21 Replacement of sensors for the drive system fans
Continued

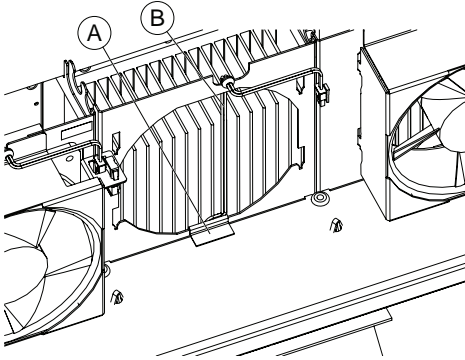
	Action	Note /illustration
8	Lift the sensor holder and remove it together with the sensor cable.	 <p>xx1500000857</p> <p>A Sensor holder B Sensor cable</p>

Refitting

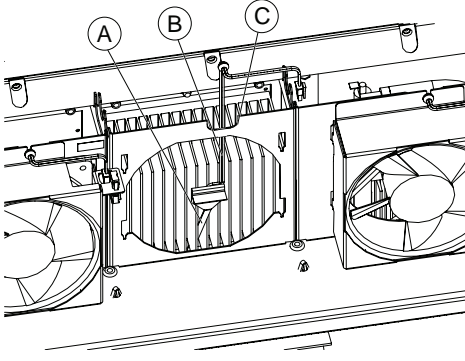
	Action	Note/illustration
1	 DANGER Before doing any work inside the cabinet, disconnect the mains power. For more information, see Electrical safety on page 37 .	
2	Insert the sensor between the heat sink fins in the middle.	 <p>xx1500000858</p> <p>A Sensor on sensor holder B Sensor cable C Fan channel bracket</p>
3	Route the fan cable behind the fan channel bracket.	

Continues on next page

4 Repair

4.21 Replacement of sensors for the drive system fans

Continued

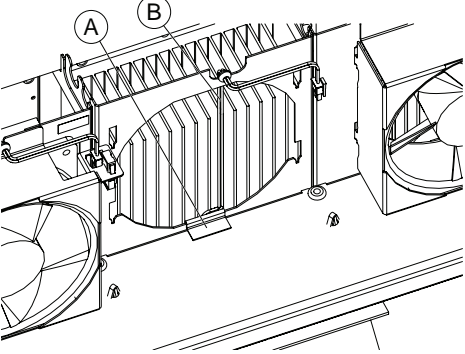
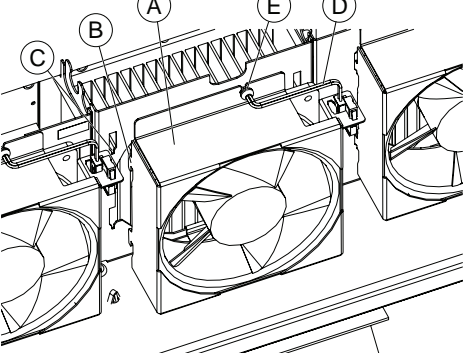
	Action	Note/illustration
4	Fit the sensor holder on the edge of the fan channel bracket.	 <p>xx1500000857</p> <p>A Sensor holder B Sensor cable</p>
5	Refit the fan by placing the latches in the back of the fan housing into the grooves and press the fan down.	 <p>xx1500000856</p> <p>A Fan B Latches C Grooves D Temp sensor cable E Cable gland</p>
6	Slide the cable gland into the indentation in the fan housing. Gently pull the cable so there is no slack on the cable between the sensor and the cable gland.	
7	Reconnect the connectors to the fan.	
8	Refit the cover and the attachment screws.	
9	Refit the moist dust filter magazine. (Option)	
10	Perform the function tests in section Function tests on page 213 to verify that the safety features work properly.	

4.22 Replacement of transformer unit

Location

The illustration below shows the location of the transformer unit in the controller.

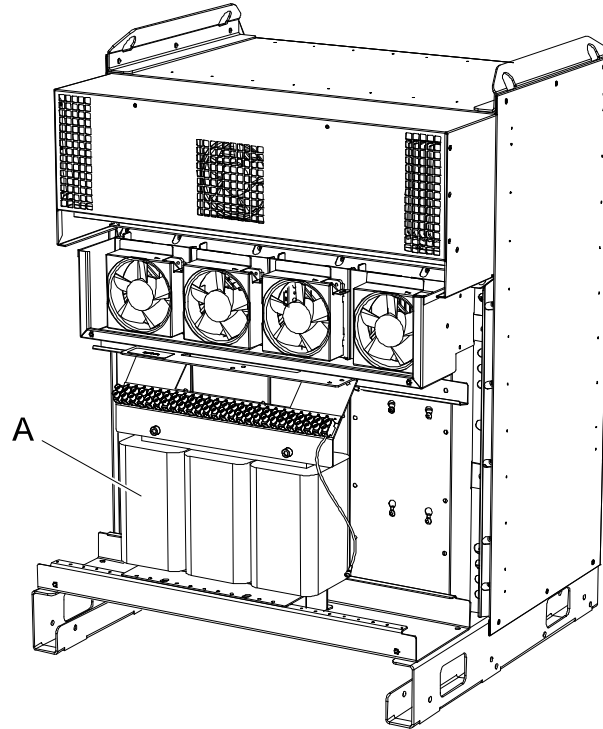

xx0500002028

A	Transformer
---	-------------

Required equipment

Equipment	Note
Transformer unit	13kVA, 6kVA, 4.2kVA, 1.2kVA See Spare parts on page 327 .
Standard toolkit	The contents are defined in section Standard toolkit
Circuit diagram	See Circuit diagrams on page 349 .

Removal

The following procedures details how to remove the transformer unit.



	Action	Note/illustration
1	 DANGER Before doing any work inside the cabinet, disconnect the mains power. For more information, see Electrical safety on page 37 .	

Continues on next page

4 Repair

4.22 Replacement of transformer unit

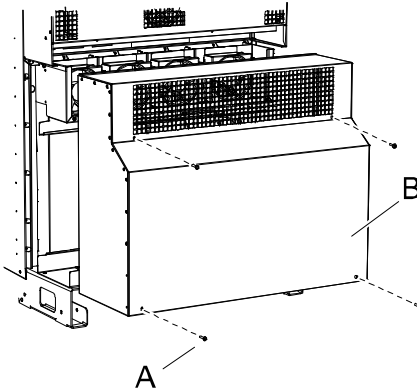
Continued

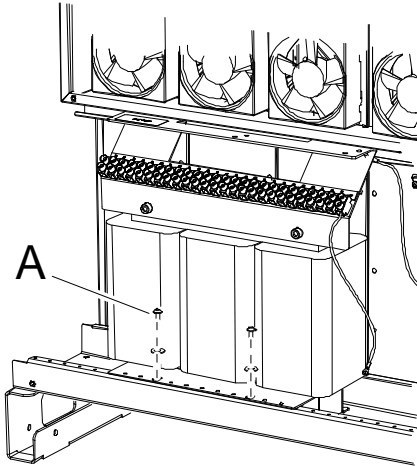

	Action	Note/illustration
2	 WARNING The transformer weighs between 15 and 40 kg, use a hoist and lifting slings.	
3	Remove the moist dust filter magazine. (Option)	How to remove the moist dust filter magazine is detailed in section Replacement of moist dust filter on page 205 .
4	Loosen the attachment screws.	 <p>xx0500002027</p> <ul style="list-style-type: none"> • A: attachment screw (4pcs) • B: cover
5	Remove the cover.	
6	Disconnect the two grounding wires (green, blue).	
7	Disconnect the mains power supply wires.	 Note Make a note of the terminal to which each of the wires are connected. This will facilitate reconnection to the same terminal.
8	Remove the two transformer attachment screws.	 <p>xx0500002032</p> <ul style="list-style-type: none"> • A: attachment screw (2pcs)

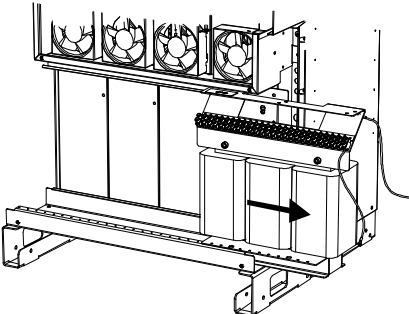
Continues on next page

	Action	Note/illustration
9	Push the transformer unit side ways and lift it out with lifting slings and a hoist.	 <p data-bbox="1023 633 1129 651">xx0500002033</p>

Refitting

The following procedure details how to refit the transformer unit.

	Action
1	 <p data-bbox="592 887 699 913">DANGER</p> <p data-bbox="504 947 1433 1003">Before doing any work inside the cabinet, disconnect the mains power. For more information, see Electrical safety on page 37.</p>
2	 <p data-bbox="592 1066 715 1093">WARNING</p> <p data-bbox="504 1126 1345 1153">The transformer weighs between 15 and 40 kg, use a hoist and lifting slings.</p>
3	Fit the new transformer in place with a hoist and lifting slings.
4	Refit the attachment screws.
5	Reconnect the mains power supply wires and grounding wires.
6	Refit the cover.
7	Refit the moist dust filter magazine. (Option)
8	Perform the function tests in section Function tests on page 213 to verify that the safety features work properly.

4 Repair

4.23 Replacement of brake resistor bleeder

4.23 Replacement of brake resistor bleeder

Location

The illustration below shows the location of the brake resistor bleeder in the controller (behind the cover).

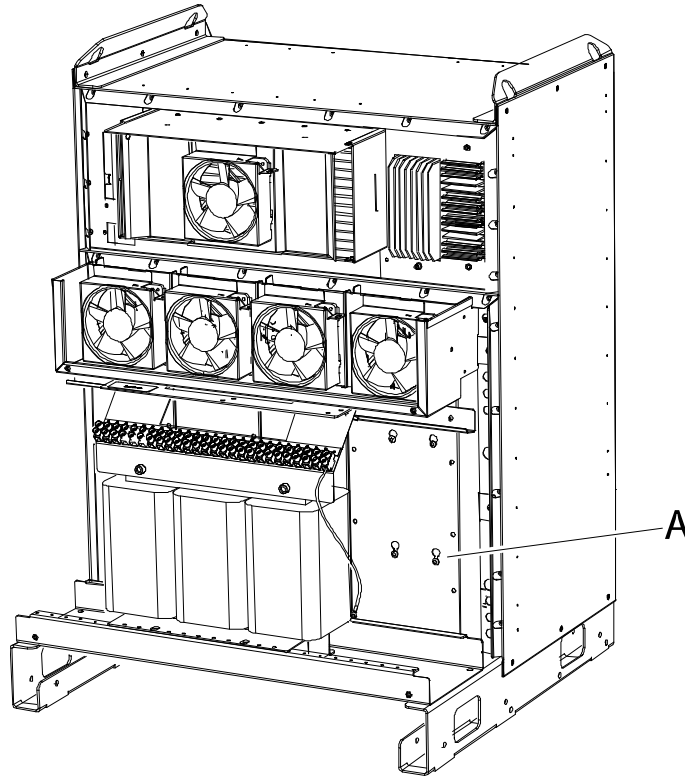

xx0500002022

A	Brake resistor bleeder (behind the cover, not visible).
---	---



Required equipment

Equipment	Note
Brake resistor bleeder	See Spare parts on page 327 .
Standard toolkit	The contents are defined in section Standard toolkit
Other tools and procedures may be required. See references to these procedures in the step-by-step instructions below.	These procedures include references to the tools required.
Circuit diagram	See Circuit diagrams on page 349 .

Continues on next page

Removal

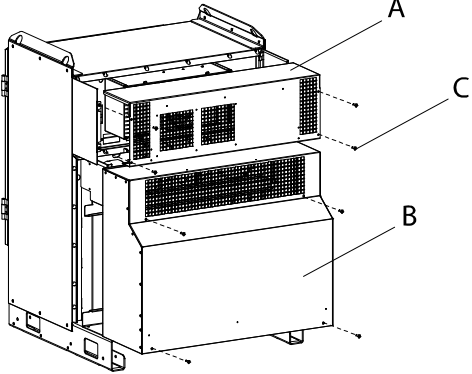
The following procedure details how to remove the brake resistor bleeder.

	Action	Note/illustration
1	 <p>DANGER</p> <p>Before doing any work inside the cabinet, disconnect the mains power. For more information, see Electrical safety on page 37.</p>	
2	Remove the moist dust filter magazine. (Option)	How to remove the moist dust filter magazine is detailed in section Replacement of moist dust filter on page 205 .
3	Remove the covers in the back of the controller.	 <p>xx0700000418</p> <ul style="list-style-type: none"> • A: top cover • B: transformer cover • C: attachment screw (8 pcs)
4	 <p>CAUTION</p> <p>If the controller is equipped with temperature sensor controlled fans, remove the sensor at the bleeder before removing the bleeder. See Replacement of sensors for the drive system fans on page 287.</p> <p>Attempting to remove the bleeder with the sensor still in place will cause the sensor holder to be bent and the sensor will measure the temperature in the wrong place. This will result in too high temperature in the controller cabinet and shorter life time for the components.</p>	

Continues on next page

4 Repair

4.23 Replacement of brake resistor bleeder

Continued

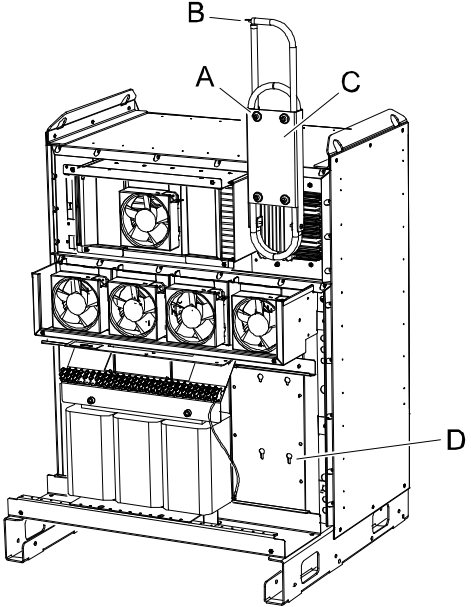
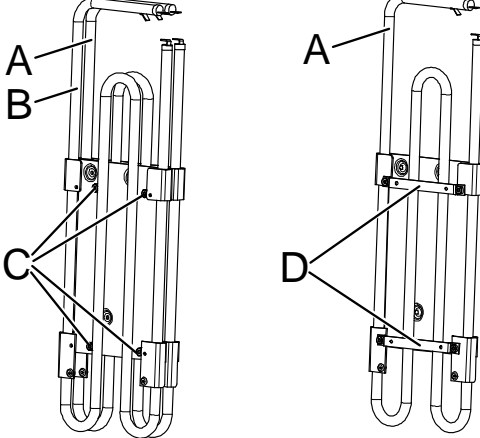
	Action	Note/illustration
5	Disconnect the two connectors from the bleeder.	 <p>xx0500002020</p> <ul style="list-style-type: none"> • A: attachment screw (4 pcs) • B: connectors • C: brake resistor bleeder • D: bleeder attachment screw (4 pcs)
6	Loosen the <i>attachment screws</i> for the brake resistor bleeder.	
7	Lift the <i>bleeder</i> slightly and push it in to release the attachments.	
8	Lift the <i>bleeder</i> straight up.	
9	<p>If the IRC5 controller uses an Additional Rectifier Unit, an extra ARU bleeder is mounted on the MDU bleeder.</p> <p>Remove the attachment screws and remove the ARU bleeder from the MDU bleeder.</p> <p>Remove the mounting brackets for the ARU bleeder.</p>	 <p>xx1000000030</p> <ul style="list-style-type: none"> • A: MDU bleeder • B: ARU bleeder • C: Attachment screws • D: Mounting brackets for ARU bleeder

Continues on next page

Refitting

The following procedure details how to refit the brake resistor bleeder.

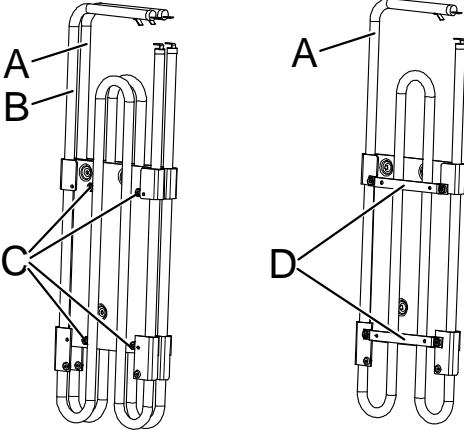
	Action	Note/illustration
1	<p> DANGER</p> <p>Before doing any work inside the cabinet, disconnect the mains power. For more information, see Electrical safety on page 37.</p>	
2	<p>If the IRC5 controller uses an Additional Rectifier Unit, an extra ARU bleeder is required.</p> <p>Attach the mounting brackets for ARU bleeder on the MDU bleeder.</p> <p>Attach the ARU bleeder to the MDU bleeder.</p>	 <p>xx100000030</p> <ul style="list-style-type: none"> • A: MDU bleeder • B: ARU bleeder • C: Attachment screws • D: Mounting brackets for ARU bleeder

Continues on next page

4 Repair

4.23 Replacement of brake resistor bleeder

Continued

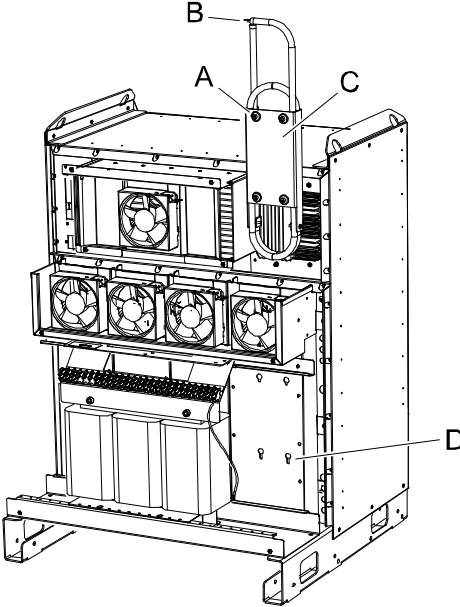
	Action	Note/illustration
3	Slide the new bleeder in to place and fit the attachment screws in the key hole attachments.	 <p data-bbox="944 929 1050 952">xx0500002020</p> <ul data-bbox="976 958 1406 1086" style="list-style-type: none">• A: attachment screw (4 pcs)• B: connectors• C: brake resistor bleeder• D: bleeder attachment screw (4 pcs)
4	Tightening the four <i>attachment screws</i> .	
5	Reconnect the <i>connectors</i> .	
6	Refit the covers.	
7	Refit the moist dust filter magazine. (Option)	
8	Perform the function tests in section Function tests on page 213 to verify that the safety features work properly.	

4.24 Replacement of Process Interface Board

About the Process Interface Board

A Process Interface Board is mounted in the controller cabinet if option *DispensePac support* is used.

Location

The illustration below shows the location of the Process Interface Board.

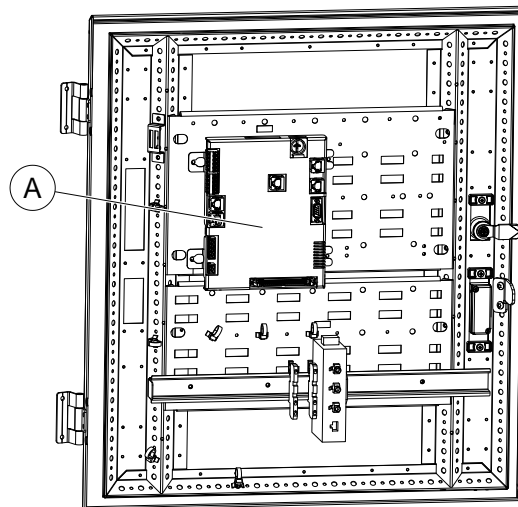

xx130000812

A	Process Interface Board
---	-------------------------

Required equipment

Equipment	Note
Standard toolkit	The contents are defined in section Standard toolkit

Removing the Process Interface Board

Action	
1	<p> DANGER</p> <p>Before doing any work inside the cabinet, disconnect the mains power. For more information, see Electrical safety on page 37.</p>

Continues on next page



4 Repair

4.24 Replacement of Process Interface Board

Continued

	Action
2	 WARNING The unit is sensitive to ESD. Before handling the unit please read the safety information in the section The unit is sensitive to ESD on page 49
3	Disconnect all connectors from the Process Interface Board.
4	Remove the 4 attachment screws and remove the board.

Refitting the Process Interface Board

	Action
1	 DANGER Before doing any work inside the cabinet, disconnect the mains power. For more information, see Electrical safety on page 37 .
2	 WARNING The unit is sensitive to ESD. Before handling the unit please read the safety information in the section The unit is sensitive to ESD on page 49
3	Fit the Process Interface Board on the attachment plate and fasten it with the 4 attachment screws.
4	Connect all connectors to the Process Interface Board.
5	Perform the function tests in section Function tests on page 213 to verify that the safety features work properly.

4.25 Replacement of Ethernet switch

General

For some options an Ethernet switch is mounted in the controller.

Location

The illustration below shows the location of the Ethernet switch.

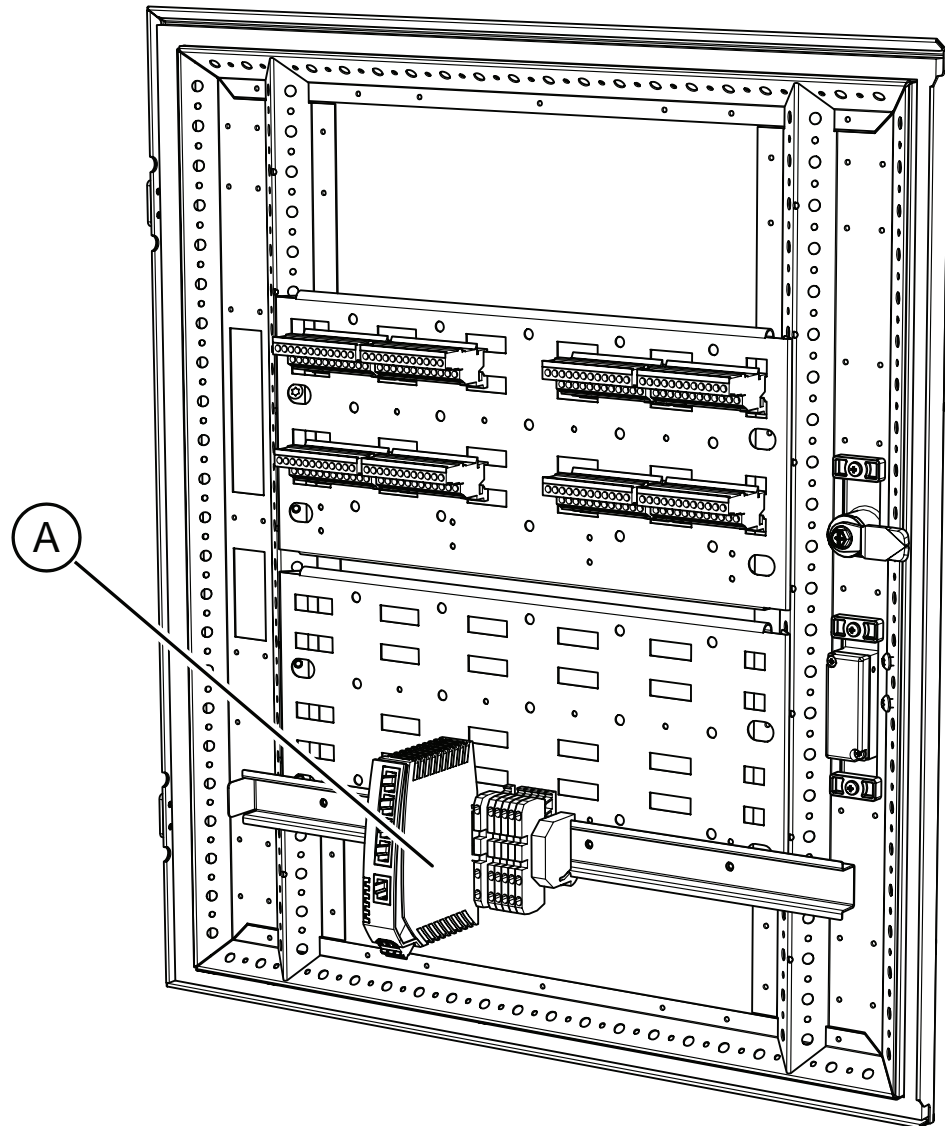

xx130000814

B	Ethernet switch
---	-----------------



Continues on next page

4 Repair



4.25 Replacement of Ethernet switch

Continued

Removing the switch

	Action
1	 DANGER Before doing any work inside the cabinet, disconnect the mains power. For more information, see Electrical safety on page 37 .
2	 WARNING The unit is sensitive to ESD. Before handling the unit please read the safety information in the section The unit is sensitive to ESD on page 49
3	Disconnect all connectors from the switch.
4	Pull the spring lock to remove the switch.

Refitting the switch

	Action
1	 DANGER Before doing any work inside the cabinet, disconnect the mains power. For more information, see Electrical safety on page 37 .
2	 WARNING The unit is sensitive to ESD. Before handling the unit please read the safety information in the section The unit is sensitive to ESD on page 49
3	Pull the spring lock and attach the switch to the mounting bar.
4	Connect all connectors to the switch.
5	Perform the function tests in section Function tests on page 213 to verify that the safety features work properly.

4.26 Replacement of power supply

4.26.1 Replacement of power distribution unit

Location

The power distribution unit, DSQC 662, is located on the left side as shown in the illustration below.

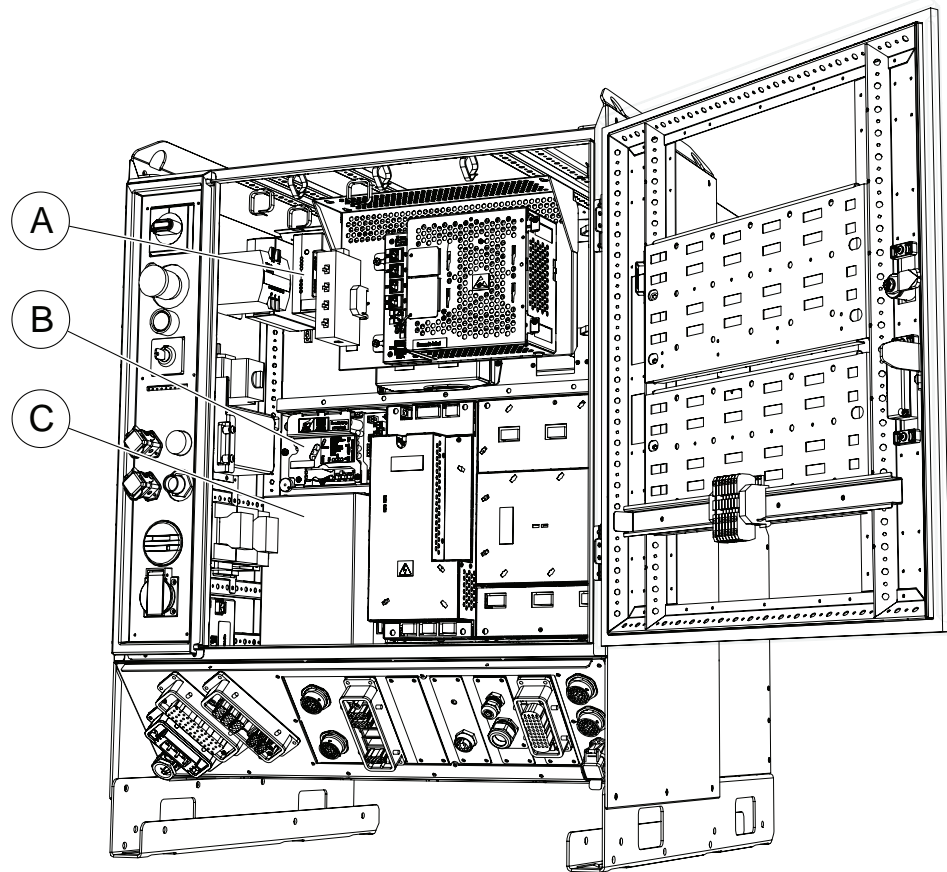

xx130000813

A	Customer I/O power supply
B	Power distribution unit
C	System power supply



CAUTION

Hot surface on top of the power distribution unit.

Risk of burns. Be careful when removing the unit.

Do not route or place cables on top of the power distribution unit.

Continues on next page

4 Repair

4.26.1 Replacement of power distribution unit



Continued

Required equipment

Equipment	Article number	Note
Power distribution unit	3HAC026254-001	DSQC 662
Standard toolkit		The contents are defined in section Standard toolkit.
Other tools and procedures may be required. See references to these procedures in the step-by-step instructions below.		
Circuit diagram	See Circuit diagrams on page 349 .	

Removal

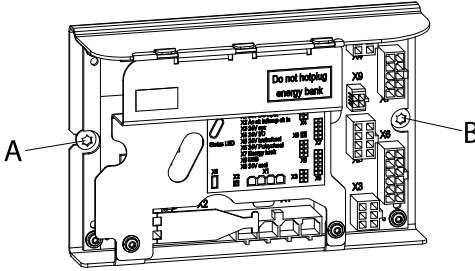

The procedure below details how to remove the power distribution unit.

Action	Note/Illustration
<p>1</p>  <p>DANGER</p> <p>Before doing any work inside the cabinet, disconnect the mains power. For more information, see Electrical safety on page 37.</p>	
<p>2</p>  <p>CAUTION</p> <p>Hot surface on top of the power distribution unit. Risk of burns. Be careful when removing the unit.</p>	
<p>3</p> <p>Disconnect the connectors X1 - X9 on the power distribution unit.</p>	
<p>4</p> <p>Loosen the left attachment screw, remove the right attachment screw and pull the power distribution unit rightward to release it from the left screw head.</p>	 <p>xx0700000122</p> <ul style="list-style-type: none"> A: left attachment screw B: right attachment screw
<p>5</p> <p>Remove the power distribution unit.</p>	

Continues on next page

Refitting

The procedure below details how to refit the power distribution unit.

	Action	Note/Illustration
1	 DANGER Before doing any work inside the cabinet, disconnect the mains power. For more information, see Electrical safety on page 37 .	
2	Refit the new power distribution unit by pushing it leftward to fit the left screw head. Refit the right screw.	
3	Lock the unit in place by tighten the attachment screws.	
4	Reconnect the connectors X1 - X9.	 CAUTION Hot surface on top of the power distribution unit. Do not route or place cables on top of the power distribution unit.
5	Perform the function tests in section Function tests on page 213 to verify that the safety features work properly.	

4 Repair

4.26.2 Replacement of customer I/O power supply

4.26.2 Replacement of customer I/O power supply

Location

The customer I/O power supply, DSQC 609, is located as shown in the figure below.

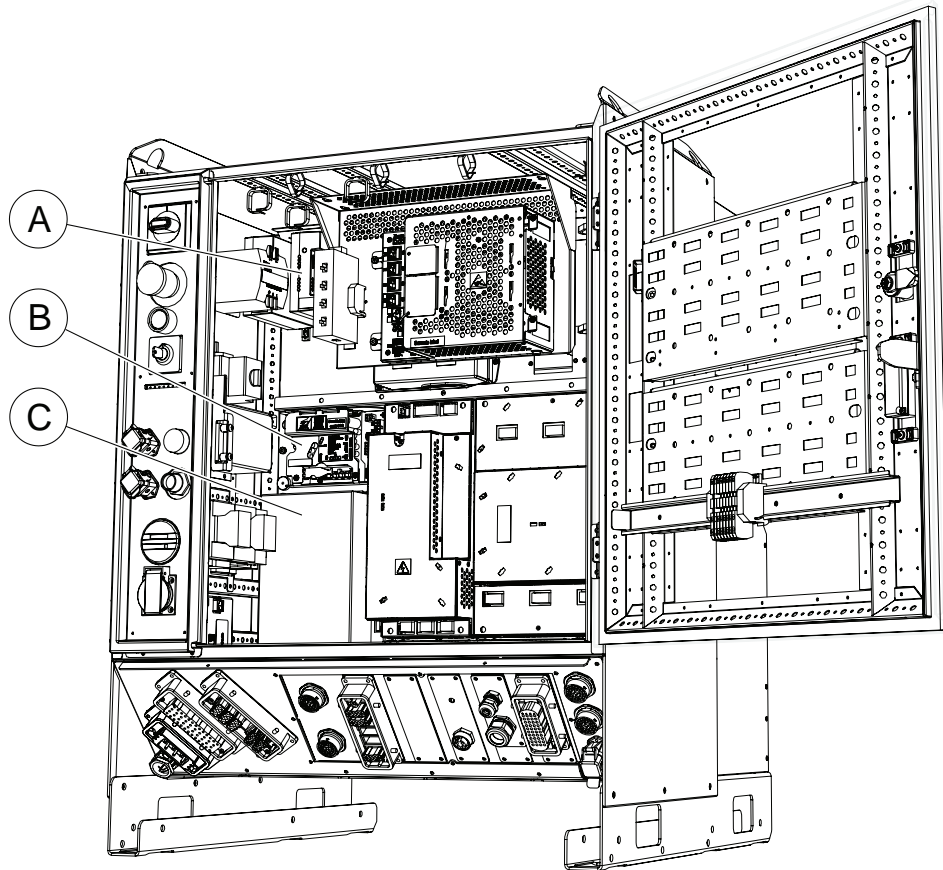

xx130000813

A	Customer I/O power supply
B	Power distribution unit
C	System power supply



CAUTION

If there are two or more Customer I/O power supply units mounted in a row and too close to each other, there will be a heating problem and the units can be damaged.

To avoid damaging the Customer I/O power supply units, the units must be separated with 3 pcs of exterior support.

Required equipment

Equipment	Article number	Note
Customer I/O power supply	3HAC14178-1	DSQC 609

Continues on next page

4.26.2 Replacement of customer I/O power supply
Continued

Equipment	Article number	Note
Standard toolkit		The contents are defined in section Standard toolkit.
Other tools and procedures may be required. See references to these procedures in the step-by-step instructions below.		These procedures include references to the tools required.
Circuit diagram	See Circuit diagrams on page 349 .	

Removal

The procedure below details how to remove the customer I/O power supply.

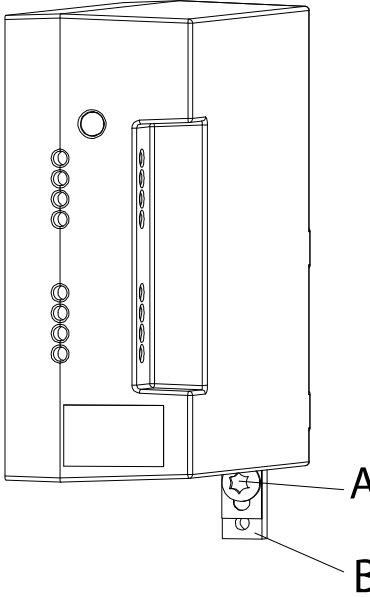
	Action	Note/Illustration
1	 DANGER Before doing any work inside the cabinet, disconnect the mains power. For more information, see Electrical safety on page 37 .	
2	Remove the Flange disconnect unit (option).	Detailed in section Replacement of Flange disconnect on page 229
3	Loosen the terminal screws for each connected wire. Remove wires from the terminals.	
4	Loosen the DIN-lock fixing screw.	 <p>xx070000124</p> <ul style="list-style-type: none"> • A: DIN-lock fixing screw • B: DIN-lock lever
5	Pull the DIN-lock lever downwards to release the power supply unit.	
6	Remove the power supply unit.	

Continues on next page

4 Repair

4.26.2 Replacement of customer I/O power supply

Continued

Refitting

The procedure below details how to refit the customer I/O power supply.

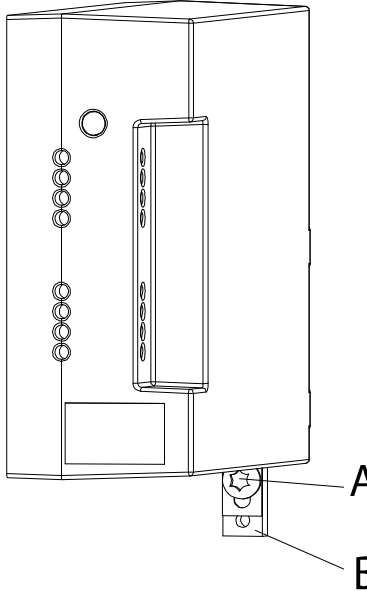
	Action	Note/Illustration
1	 <p>DANGER</p> <p>Before doing any work inside the cabinet, disconnect the mains power. For more information, see Electrical safety on page 37.</p>	
2	Refit the new power supply unit on the DIN-rail.	
3	Fasten the DIN-lock fixing screw.	 <p>xx070000124</p> <ul style="list-style-type: none"> • A: DIN-lock fixing screw • B: DIN-lock lever
4	Refit all wires in the screw terminals.	
5	Fasten the screw terminal screws with correct torque.	
6	Refit the Flange disconnect unit (option).	
7	Perform the function tests in section Function tests on page 213 to verify that the safety features work properly.	

4.26.3 Replacement of system power supply

Location

The illustration below shows the location of the system power supply, DSQC 661, in the controller.

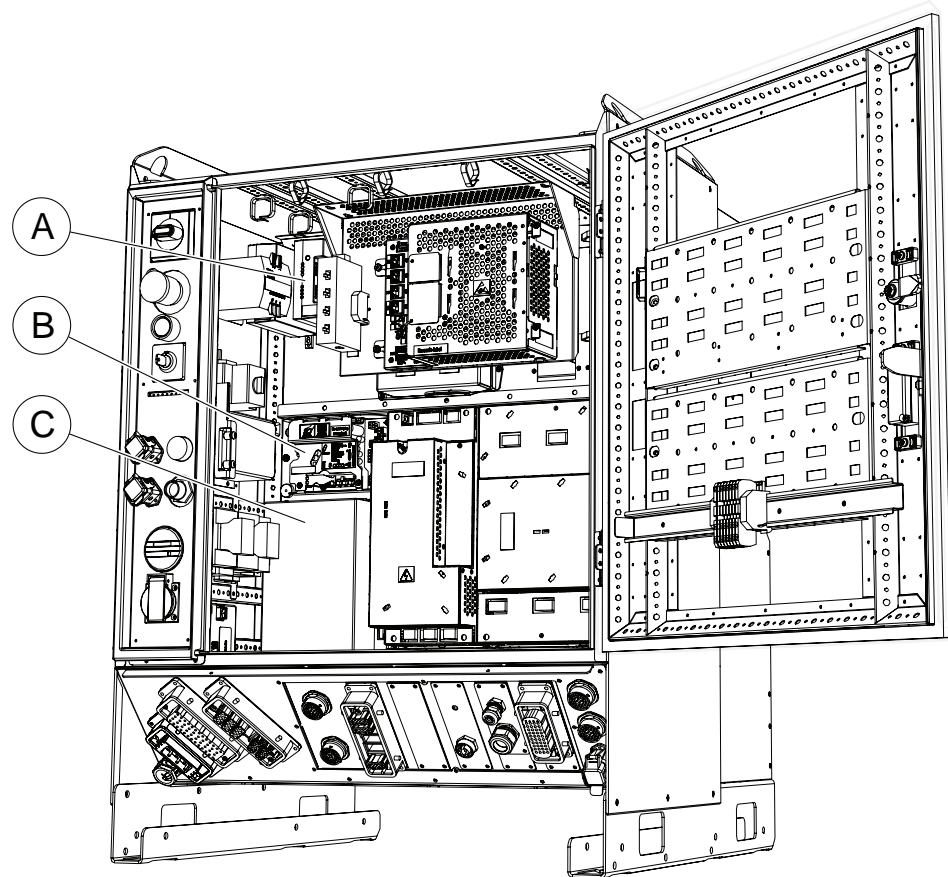

xx130000813

A	Customer I/O power supply
B	Power distribution unit
C	System power supply

Required equipment

Equipment	Article number	Note
System power supply	3HAC026253-001	DSQC 661
Standard toolkit		The contents are defined in section Standard toolkit.
Other tools and procedures may be required. See references to these procedures in the step-by-step instructions below.		
Circuit diagram	See Circuit diagrams on page 349 .	

Continues on next page

4 Repair

4.26.3 Replacement of system power supply

Continued

Removal

The procedure below details how to remove the system power supply.

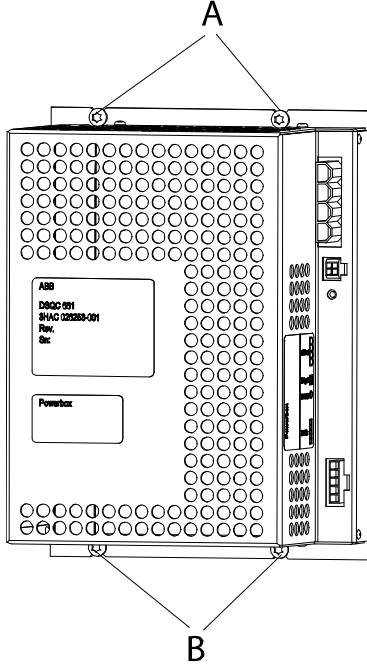
	Action	Note/Illustration
1	 DANGER Before doing any work inside the cabinet, disconnect the mains power. For more information, see Electrical safety on page 37 .	
2	Disconnect all connectors from the unit.	
3	Loosen the two lower attachment screws.	 <p>xx0700000125</p> <ul style="list-style-type: none"> • A: upper attachment screws • B: lower attachment screws
4	Remove the two upper attachment screws.	
5	Pull the power supply unit outwards and then upwards to release it from the lower screw heads, and remove it.	

Refitting

The procedure below details how to refit the system power supply.

	Action	Note/Illustration
1	 DANGER Before doing any work inside the cabinet, disconnect the mains power. For more information, see Electrical safety on page 37 .	

Continues on next page

4.26.3 Replacement of system power supply
Continued

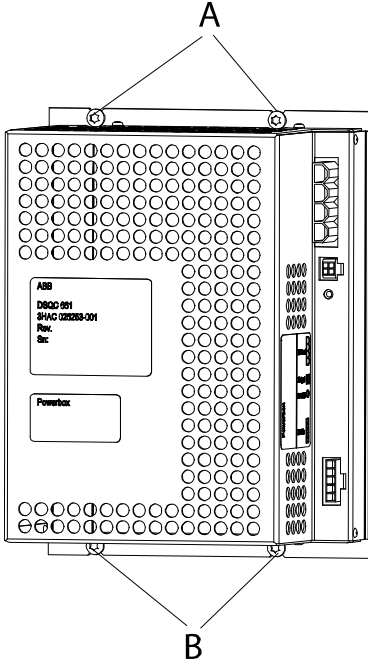
	Action	Note/Illustration
2	Refit the power supply by sliding the recesses in beneath the lower screw heads, and push it inwards and the downwards.	 <p>xx0700000125</p> <ul style="list-style-type: none"> • A: upper attachment screws • B: lower attachment screws
3	Refit the two upper attachment screws.	
4	Tighten the attachment screws (4 pcs).	
5	Reconnect all connectors to the unit.	
6	Perform the function tests in section Function tests on page 213 to verify that the safety features work properly.	

This page is intentionally left blank

5 Decommissioning

5.1 Introduction to decommissioning

Introduction

This section contains information to consider when taking a product, robot or controller, out of operation.

It deals with how to handle potentially dangerous components and potentially hazardous materials.



Note

The decommissioning process shall be preceded by a risk assessment.

Disposal of materials used in the robot

All used grease/oils and dead batteries **must** be disposed of in accordance with the current legislation of the country in which the robot and the control unit are installed.

If the robot or the control unit is partially or completely disposed of, the various parts **must** be grouped together according to their nature (which is all iron together and all plastic together), and disposed of accordingly. These parts **must** also be disposed of in accordance with the current legislation of the country in which the robot and control unit are installed.

See also [Environmental information on page 314](#).

Disposal of storage media

Before disposal of any storage equipment (anything from an SD card to a complete controller), make sure that all sensitive information has been deleted.



Tip

To remove all data from the SD card, use the **Clean Disk** function (part of **Recovery Disk** function) in RobotStudio. See *Operating manual - RobotStudio*.

Transportation

Prepare the robot or parts before transport, this to avoid hazards.

5 Decommissioning

5.2 Environmental information

5.2 Environmental information

Introduction

ABB robots contain components in different materials. During decommissioning, all materials shall be dismantled, recycled, or reused responsibly, according to the relevant laws and industrial standards. Robots or parts that can be reused or upcycled helps to reduce the usage of natural resources.

Disposal symbol

The following symbol indicates that the product must not be disposed of as common garbage. Handle each product according to local regulations for the respective content (see table below).



xx180000058

Materials used in the product

The table specifies some of the materials in the product and their respective use throughout the product.

Dispose components properly according to local regulations to prevent health or environmental hazards.

Material	Example application
Aluminium	Heat sinks on power supplies and drive units
Batteries, Lithium	Main computer
Brominated flame retardants	Electronics
Copper	Cables
Lead	Electronics
Plastic/rubber	Cables, connectors, etc.
Steel	Cabinet structure, plates, screws, etc.

China RoHS symbol

The following symbol shows the information to hazardous substances and the environmental protection use period of IRC5 according to "Management Methods

Continues on next page

for the Restriction of the Use of Hazardous Substances in Electrical and Electronic Products (SJ/T 11364-2014) ".



xx190000803

Green symbol with "e" in it: The product does not contain any hazardous substances exceeding concentration limits and is a green environmentally friendly product which can be recycled.

This page is intentionally left blank

6 Reference information

6.1 Introduction

General

This chapter includes general information, complementing the more specific information in the different procedures in the manual.

6 Reference information

6.2 Applicable standards

6.2 Applicable standards



Note

The listed standards are valid at the time of the release of this document. Phased out or replaced standards are removed from the list when needed.

General

The product is designed in accordance with ISO 10218-1:2011, Robots for industrial environments - Safety requirements -Part 1 Robots, and applicable parts in the normative references, as referred to from ISO 10218-1:2011. In case of deviations from ISO 10218-1:2011, these are listed in the declaration of incorporation which is part of the product delivery.

Normative standards as referred to from ISO 10218-1

Standard	Description
ISO 9283:1998	Manipulating industrial robots - Performance criteria and related test methods
ISO 10218-2	Robots and robotic devices - Safety requirements for industrial robots - Part 2: Robot systems and integration
ISO 12100	Safety of machinery - General principles for design - Risk assessment and risk reduction
ISO 13849-1:2006	Safety of machinery - Safety related parts of control systems - Part 1: General principles for design
ISO 13850	Safety of machinery - Emergency stop - Principles for design
IEC 60204-1	Safety of machinery - Electrical equipment of machines - Part 1: General requirements

Deviations from ISO 10218-1:2011 for IRC5 with MultiMove

A deviation exists towards ISO 10218-1:2011, paragraph 5.9 *Control of simultaneous motion*, for the option MultiMove. See the application manual for MultiMove.

Region specific standards and regulations

Standard	Description
ANSI/RIA R15.06	Safety requirements for industrial robots and robot systems
ANSI/UL 1740	Safety standard for robots and robotic equipment
CAN/CSA Z 434	Industrial robots and robot Systems - General safety requirements

Other standards used in design

Standard	Description
ISO 9787:2013	Robots and robotic devices -- Coordinate systems and motion nomenclatures
IEC 61000-6-2	Electromagnetic compatibility (EMC) – Part 6-2: Generic standards – Immunity standard for industrial environments

Continues on next page

6 Reference information

6.2 Applicable standards

Continued

Standard	Description
IEC 61000-6-4	Electromagnetic compatibility (EMC) – Part 6-4: Generic standards – Emission standard for industrial environments
ISO 13732-1:2006	Ergonomics of the thermal environment - Part 1
IEC 60974-1:2012 ⁱ	Arc welding equipment - Part 1: Welding power sources
IEC 60974-10:2014 ^f	Arc welding equipment - Part 10: EMC requirements
ISO 14644-1:2015 ⁱⁱ	Classification of air cleanliness
IEC 60529:1989 + A2:2013	Degrees of protection provided by enclosures (IP code)

ⁱ Only valid for arc welding robots. Replaces IEC 61000-6-4 for arc welding robots.

ⁱⁱ Only robots with protection Clean Room.

6 Reference information

6.3 Unit conversion

6.3 Unit conversion

Converter table

Use the following table to convert units used in this manual.

Quantity	Units		
Length	1 m	3.28 ft.	39.37 in
Weight	1 kg	2.21 lb.	
Weight	1 g	0.035 ounces	
Pressure	1 bar	100 kPa	14.5 psi
Force	1 N	0.225 lbf	
Moment	1 Nm	0.738 lbf-ft	
Volume	1 L	0.264 US gal	

6.4 Screw joints

General

This section details how to tighten the various types of screw joints on the controller. The instructions and torque values are valid for screw joints comprised of metallic materials and do *not* apply to soft or brittle materials.

Tightening torque

Before tightening any screw, note the following:

- Determine whether a standard tightening torque or special torque is to be applied. The standard torques are specified in the tables below. Any special torques are specified in the Repair, Maintenance or Installation procedure description. Any special torque specified overrides the standard value.
- Use the *correct tightening torque* for each type of screw joint.
- Only use *correctly calibrated* torque keys.
- Always *tighten the joint by hand*, and never use pneumatical tools.
- Use the *correct tightening technique*, i.e. *do not* jerk. Tighten the screw in a slow, flowing motion.
- Maximum allowed total deviation from the specified value is **10%**!

The table below specifies the recommended standard tightening torque for *oil-lubricated screws with slotted or cross-recess heads*.

Dimension	Tightening torque (Nm) Class 4.8, oil-lubricated
M2.5	0.25
M3	0.5
M4	1.2
M5	2.5
M6	5.0

6 Reference information

6.5 Weight specifications

6.5 Weight specifications

Definition

In all repair and maintenance instructions, weights of the components handled are sometimes specified. All components exceeding 22 kg (50 lbs) are high-lighted in this way.

To avoid injury, ABB recommends the use of lifting equipment when handling components with a weight exceeding 22 kg.

Example

Below is an example of how a weight specification is presented:



CAUTION

The transformer weighs 55 kg! All lifting equipment used must be sized accordingly!

6.6 Standard toolkit, IRC5

General

All service (repair, maintenance and installation) instructions contain lists of tools required to perform the specified activity. All special tools, that is, all tools that are not considered as standard tools as defined below, are listed in their instructions respectively.

This way, the tools required are the sum of the Standard Toolkit and any tools listed in the instructions.

Contents, standard toolkit, IRC5

Tool	Remark
Screw driver, Torx	Tx10
Screw driver, Torx	Tx20
Screw driver, Torx	Tx25
Ball tipped screw driver, Torx	Tx25
Screw driver, flat blade	4 mm
Screw driver, flat blade	8 mm
Screw driver, flat blade	12 mm
Screw driver	Phillips-1
Box spanner	8 mm

6 Reference information

6.7 Lifting accessories and lifting instructions

6.7 Lifting accessories and lifting instructions

General

Many repair and maintenance activities require different pieces of lifting accessories, which are specified in each procedure.

The use of each piece of lifting accessories is *not* detailed in the activity procedure, but in the instruction delivered with each piece of lifting accessories.

The instructions delivered with the lifting accessories should be stored for later reference.

6.8 Open source and 3rd party components

Open source and 3rd party components

ABB products use software provided by third parties, including open source software. The following copyright statements and licenses apply to various components that are distributed inside the ABB software. Each ABB product does not necessarily use all of the listed third party software components. Licensee must fully agree and comply with these license terms or the user is not entitled to use the product. Start using the ABB software means accepting also referred license terms. The third party license terms apply only to the respective software to which the license pertains, and the third party license terms do not apply to ABB products. With regard to programs provided under the GNU general public license and the GNU lesser general public license licensor will provide licensee on demand, a machine-readable copy of the corresponding source code. This offer is valid for a period of three years after delivery of the product.

ABB software is licensed under the ABB end user license agreement, which is provided separately.

RobotWare

For RobotWare, there is license information in the folder \licenses in the RobotWare distribution package.

OpenSSL

This product includes software developed by the OpenSSL Project for use in the OpenSSL Toolkit. (<http://www.openssl.org/>)

This product includes cryptographic software written by Eric Young (eay@cryptsoft.com).

This product includes software written by Tim Hudson (tjh@cryptsoft.com).

CTM

For OleOS, the Linux based operating system used on the conveyor tracking module (CTM), a list of copyright statements and licenses is available in the file `/etc/licenses.txt` located on the CTM board and accessible via the console port or by downloading the file over SFTP.

For the CTM application, a list of copyright statements and licenses is available in the file `/opt/ABB.com/ctm/licenses.txt` located on the CTM board and accessible via the console port or by downloading the file over SFTP.

This page is intentionally left blank

7 Spare parts

7.1 Controller parts

Controller system parts

The illustration below shows the placement of the controller system parts in the recommended spare part list.

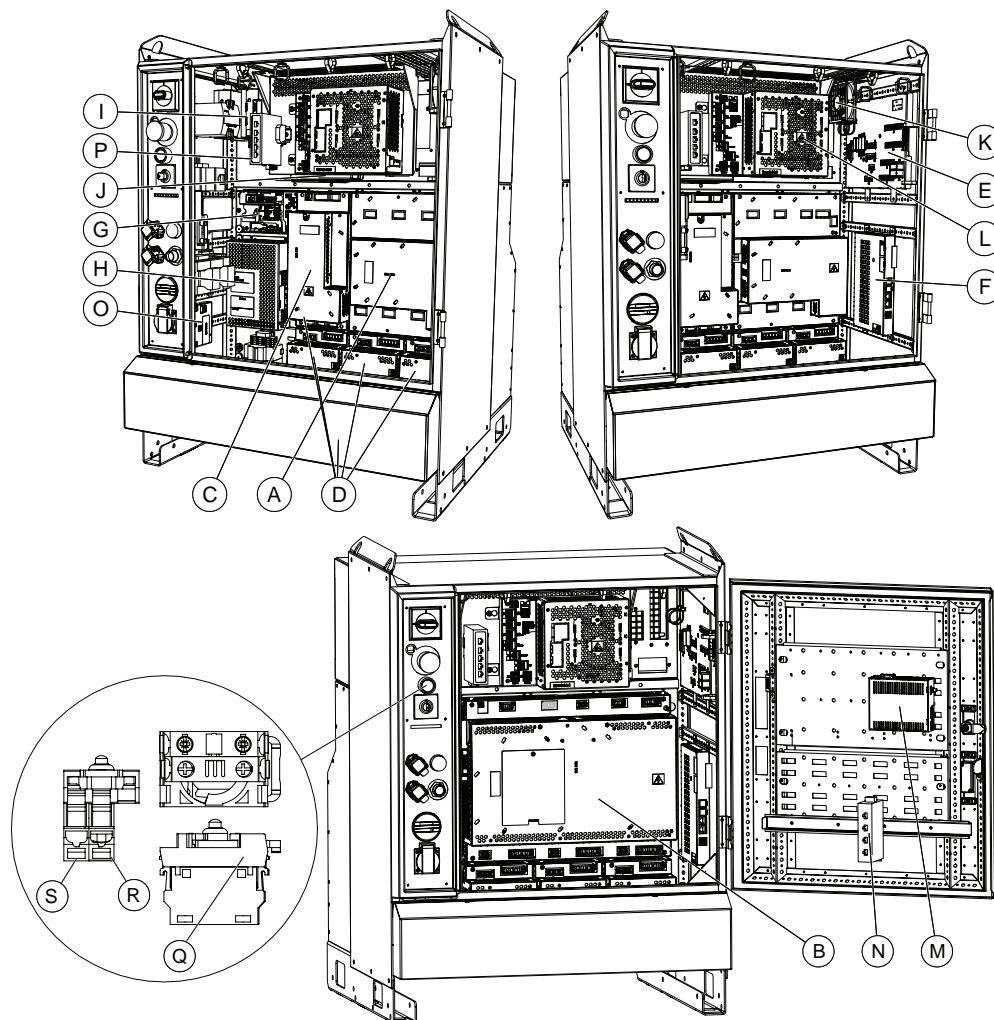

xx2300001289

	Spare part no.	Description	Type
A	3HAC035301-001	Main Drive Unit, MDU-430A (small robots)	DSQC 406
B	3HAC029818-001	Main Drive Unit, MDU-790A (large robots)	DSQC 663
C	3HAC035381-001	Additional Rectifier Unit, ARU-430A (small robots with additional drive unit)	DSQC 417
D	3HAC030923-001	Additional Drive Unit, ADU-790A	DSQC 664
E	3HAC024488-001	Panel board unit	DSQC 643
F	3HAC029157-001	Axis computer	DSQC 668
G	3HAC026254-001	Power distribution unit	DSQC 662

Continues on next page

7 Spare parts

7.1 Controller parts

Continued

	Spare part no.	Description	Type
H	3HAC026253-001	System power supply	DSQC 661
I	3HAC14178-1	Customer I/O power supply	DSQC 609
J	3HAC026585-001	Backup energy bank with adapter plate	DSQC 655
J	3HAC025562-001	Backup energy bank	DSQC 655
K	3HAC025466-001	Fan	
L	See Computer unit parts on page 331 .		
M	3HAC043053-001	Remote Service box	DSQC 680
N	3HAC082466-001	Ethernet switch (for IRC5 and PMC)	
O	3HAC13389-2	Contactor interface board	DSQC 611
P	3HAC045976-001	DSQC1007 Eth. switch (MultiMove)	DSQC1007
	3HAC056289-001	Mains line filter	
	3HAC052287-002	Mode selector 3-pos Std	
	3HAC052287-004	Mode selector 3-pos Extended	
	3HAC052287-001	Mode selector 2-pos Std	
	3HAC052287-003	Mode selector 2-pos Extended	
	3HAC022165-002	Mains switch	
	3HAC026222-002	Handle Option 744-1	
	3HAC026222-003	Handle Standard	
	1SFA619550R1051	Emergency pushbutton	
	1SFA611102R1105	Actuator white	
Q	1SFA611605R1100	Holder	
R	1SFA611621R1015	MLBL-01W Modular LED block	
S	1SFA611610R1001	Contact block	
	3HNE 01586-1	Conveyor Tracking Unit	DSQC 377B
	3HNA027579-001	CTM-01 Conveyor Tracking Module	DSQC2000

Continues on next page

DeviceNet I/O System parts

The illustration below shows the placement of the DeviceNet I/O system parts in the recommended spare part list.

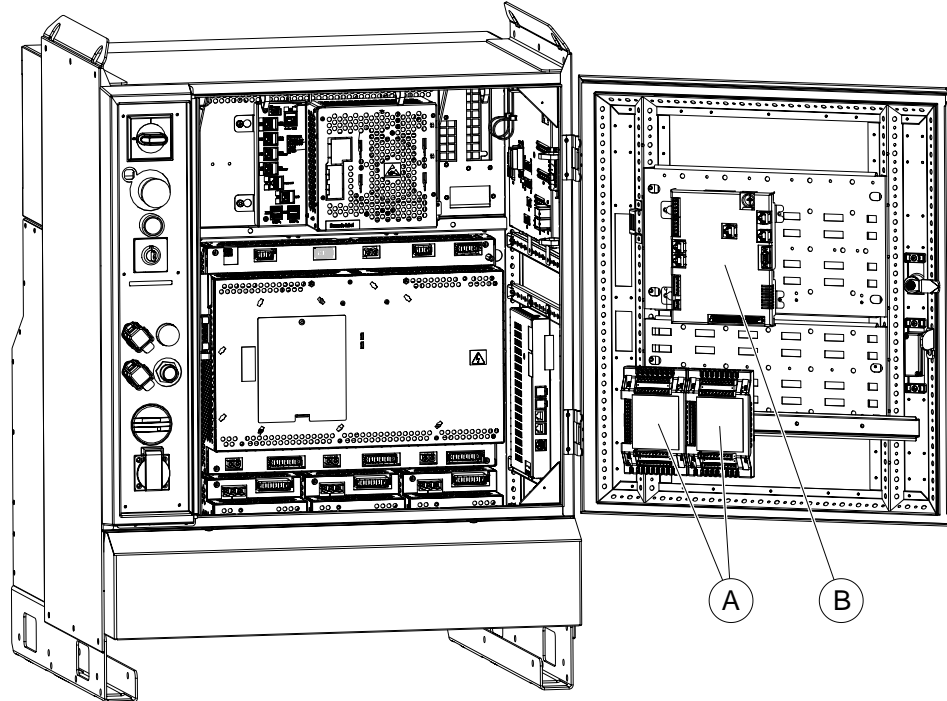

xx130000816

	Spare part no.	Description	Type
A	3HAC025784-001	ADCombi I/O unit	DSQC 651
A	3HAC025917-001	Digital I/O unit	DSQC 652
B	3HNA006144-001	Process Interface Board	

Continues on next page

7 Spare parts

7.1 Controller parts

Continued

Scalable I/O devices

The illustration below shows the base device and connected add-on devices.

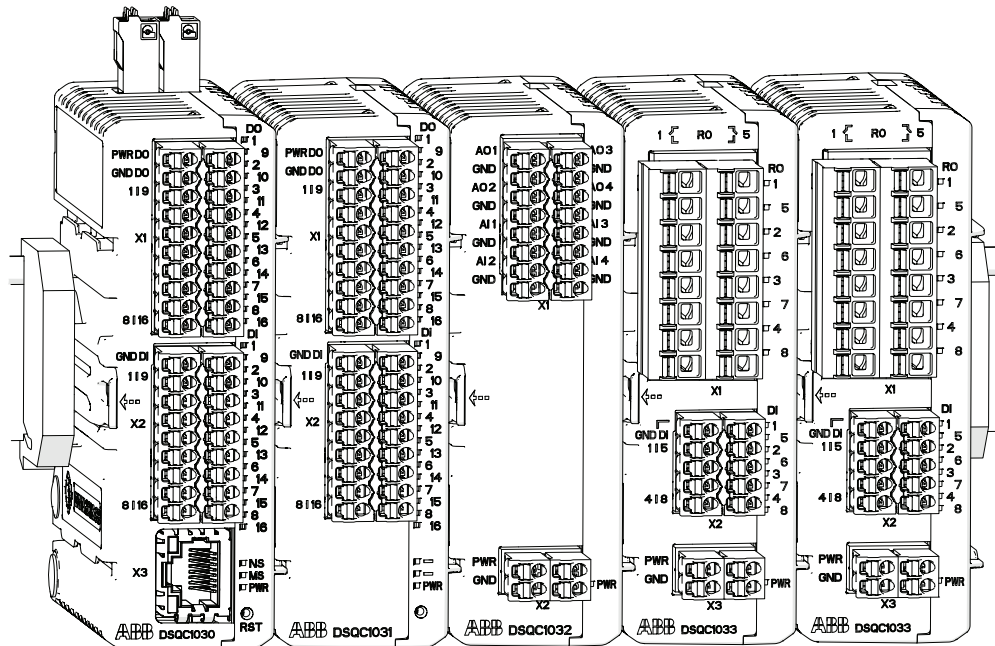

xx1600002032

Spare part no.	Description	Type
3HAC058663-001	Digital base, 16 digital inputs, 16 digital outputs	DSQC1030
3HAC058664-001	Digital add-on, 16 digital inputs, 16 digital outputs	DSQC1031
3HAC058665-001	Analog add-on, 4 analog inputs, 4 analog outputs	DSQC1032
3HAC058666-001	Relay add-on, 8 digital inputs, 8 relay outputs	DSQC1033

The main dimensions for the I/O devices are 75x36x101 (Length x Width x Height).

Additional parts

Spare part no.	Description
3HAC060919-001	Connectors digital base/add-on
3HAC060925-001	Connectors analog add-on
3HAC060926-001	Connectors relay add-on
3HAC062073-001	DIN bracket

Continues on next page

Computer unit parts

The illustration below shows the placement of the computer unit parts in the recommended spare part list.

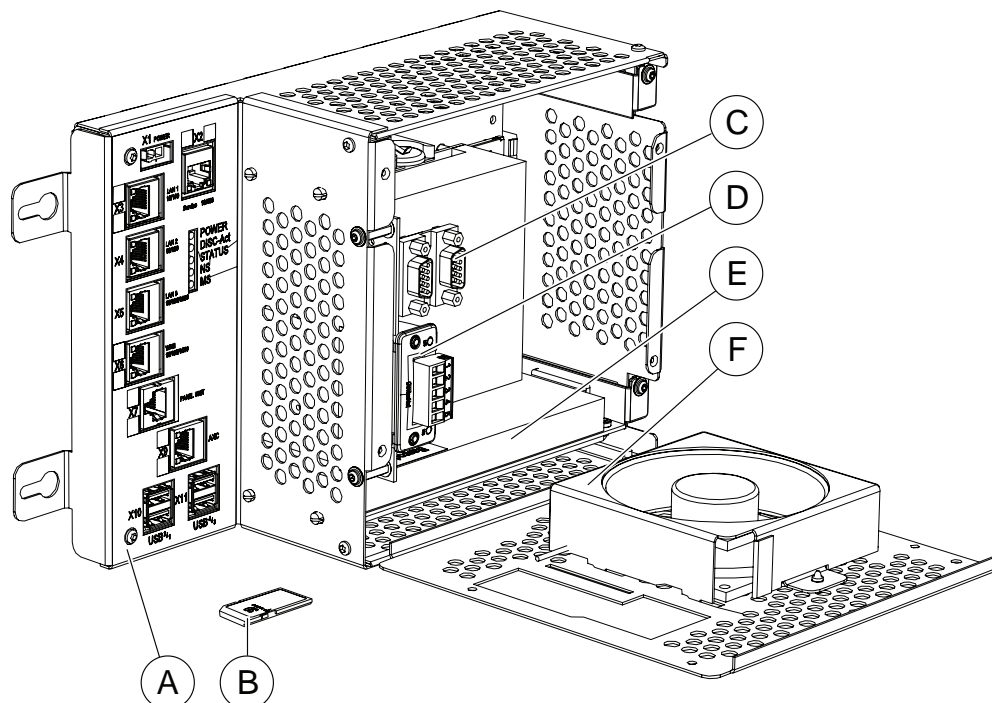

xx130000851

	Spare part no.	Description	Type
A	3HAC042766-001	Computer unit (1 PCI slot)	DSQC1000
A	3HAC050363-001	Computer unit (2 PCI slots)	DSQC1018
A	3HAC058366-001	Computer unit (2 PCI slots) Recommended for RobotWare 6.08 and later versions.	DSQC1024
A	3HAC087348-001	Computer unit (2 PCI slots) Recommended for RobotWare 6.15 and later versions.  Note Previous revisions might be supported. Contact you local ABB office for information.	DSQC1094
B	3HAC061416-003	SD card	Used with computer DSQC1000, DSQC1018, DSQC1024, DSQC1094
C	3HAC046408-001	Expansion Board complete	DSQC1003
D	3HAC031670-001	PROFINET Slave Fieldbus Adapter	DSQC 688
D	3HAC026840-001	PROFIBUS Slave Fieldbus Adapter	DSQC 667
D	3HAC027652-001	Ethernet/IP Slave Fieldbus Adapter	DSQC 669

Continues on next page

7 Spare parts

7.1 Controller parts

Continued

	Spare part no.	Description	Type
D	3HAC045973-001	DeviceNet Slave Fieldbus Adapter	DSQC1004
E	3HAC043383-001	DeviceNet Master/Slave PCIeexpress	DSQC1006
E	3HAC044872-001	PROFIBUS-DP Master PCIeexpress	DSQC1005
F	3HAC026525-001	Fan	-
-	3HAC14944-1	RS-232/422 Converter	DSQC 615

Miscellaneous parts

The illustration below shows the placement of the Miscellaneous parts in the recommended spare part list.

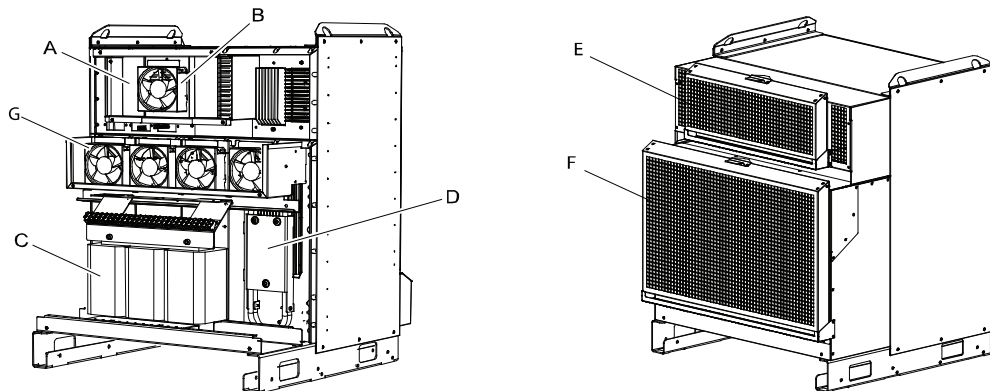

xx0600002683

	Spare part no.	Description	Note
C	3HAC037015-001	Transformer unit 400-480V	1.2kVA
C	3HAC037016-001	Transformer unit 200-220V	4.2kVA
C	3HAC037017-001	Transformer unit 400V	4.2kVA
C	3HAC037018-001	Transformer unit 440-600V	4.2kVA
C	3HAC024180-001	Transformer unit 200-600V	6kVA
C	3HAC024138-001	Transformer unit 200-600V	13kVA
A	3HAC038564-001	Heat exchange unit	52 °C
D	3HAC035583-001	Bleeder 1.8 kW ass.	Low voltage systems, IRB 120-1600
	3HAC032586-001	Bleeder Unit, 2 kW	High voltage systems, IRB 2600-7600
	3HAC050878-001	Bleeder 4 kW ass.	IRB 8700
B	3HAC029105-001	Fan	45 °C/52 °C
G	3HAC029105-001	Fan	
G	3HAC054680-001	Sensor controlled fan	Part of option 1170-1
	3HAC054852-001	Temp sensor with sensor bracket for sensor controlled fan	Part of option 1170-1
E	3HAC027697-001	Moist dust filter	Option

Continues on next page

7 Spare parts

7.1 Controller parts

Continued

	Spare part no.	Description	Note
F	3HAC027641-001	Moist dust filter	Option

7 Spare parts

7.2 FlexPendant parts

7.2 FlexPendant parts

FlexPendant versions

The FlexPendant is available in different versions, as the hardware has been updated over the years. The exact appearance on the graphics might therefore differ slightly from reality.



Note

The different versions support many, but not all, versions of the IRC5 controllers/RobotWare versions. Contact your local ABB office for more information about compatibility.

The FlexPendant holder is available in different versions, that fit different FlexPendant versions. The holder is compatible with the FlexPendant that it is delivered with.



Note

The FlexPendant for IRC5 is not compatible with OmniCore, and vice versa.

FlexPendant with emergency stop at the connector

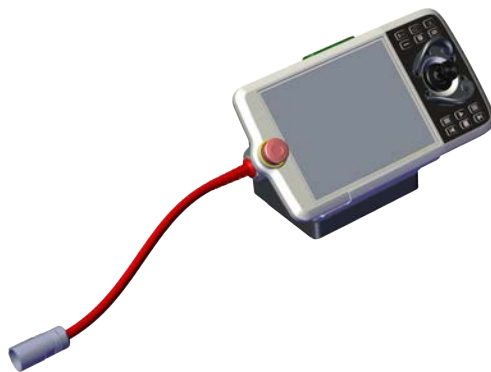

xx2100001802

Article number	Description
3HAC087622-001	FlexPendant 10 m
3HAC087622-002	FlexPendant 30 m
3HAC084673-001	10 m cable for FlexPendant
3HAC084673-002	30 m cable for FlexPendant
3HAC055665-002	FlexPendant extension cable 15 m
3HAC055665-003	FlexPendant extension cable 22 m
3HAC055665-004	FlexPendant extension cable 30 m
3HAC079391-001	TPU Holder asm (assembly)

The extension cables cannot be used together with an external operator panel (option 733-3 or 733-4).

Continues on next page

FlexPendant with emergency stop at the outer edge



xx030000449

Article number	Description
3HAC028357-001	FlexPendant with cable 10 m
3HAC031683-001	Cable 10 m for FlexPendant
3HAC031683-004	Cable 30 m for FlexPendant
3HAC055665-002	FlexPendant extension cable 15 m
3HAC055665-003	FlexPendant extension cable 22 m
3HAC055665-004	FlexPendant extension cable 30 m
3HAC033498-001	FlexPendant holder
3HAC033596-002	FlexPendant holder upper part
3HAC025042-001	Cable holder bracket
3HAC026357-001	Cable bracket
3HAC035075-001	Set of stylus
3HAC028357-050	TPU hand strap

The extension cables cannot be used together with an external operator panel (option 733-3 or 733-4).

7 Spare parts

7.3.1 Manipulator cables

7.3 Manipulator cables

7.3.1 Manipulator cables

Signal cables, IRB 120

Art. no.	Description	Option no.
3HAC035320-001	Robot cable, signal 3 m	210-1
3HAC2493-1	Robot cable, signal 7 m	210-2
3HAC2530-1	Robot cable, signal 15 m	210-3

Signal cables, IRB 1510

Art. no.	Description	Option no.
3HAC068917-001	Robot cable, signal 7 m	210-2
3HAC068918-001	Robot cable, signal 15 m	210-3

Signal cables, IRB 1200, 1410, 1520, 1600, 2600, 460, 4600, 6700, 6790, 8700

Art. no.	Description	Option no.
3HAC2493-1	Control cable signal 7 m	210-2
3HAC2530-1	Control cable signal 15 m	210-3
3HAC2540-1	Control cable signal 22 m	210-4
3HAC2566-1	Control cable signal 30 m	210-5

Signal cables, IRB 260, 660, 760, 2400, 4400, 6620, 6640, 6650S, 6660, 6650S, 7600

Art. no.	Description	Option no.
3HAC7998-1	Control cable signal 7 m	210-2
3HAC7998-2	Control cable signal 15 m	210-3
3HAC7998-3	Control cable signal 22 m	210-4
3HAC7998-4	Control cable signal 30 m	210-5

Cable packages for IRB 140 (including signal, power and customer cables)

Art. no.	Description	Option no.
3HAC7996-1	Control cable power 3 m	210-1
3HAC7996-5	Control cable power 7 m	210-2
3HAC7996-6	Control cable power 15 m	210-3
3HAC7996-7	Control cable power 22 m	210-4
3HAC7996-8	Control cable power 30 m	210-5

Continues on next page

Power cables, IRB 1410, 1600 (type A)¹

Art. no.	Description	Option no. ⁱ
3HAC2492-1	Control cable power 7 m	Standard: 210-2 and 287-4
3HAC2529-1	Control cable power 15 m	Standard: 210-3 and 287-4
3HAC2539-1	Control cable power 22 m	Standard: 210-4 and 287-4
3HAC2564-1	Control cable power 30 m	Standard: 210-5 and 287-4
3HAC9038-1	Control cable power 7 m	Foundry: 210-2 and 287-3 Wash: 210-2 and 287-5
3HAC9038-2	Control cable power 15 m	Foundry: 210-3 and 287-3 Wash: 210-3 and 287-5
3HAC9038-3	Control cable power 22 m	Foundry: 210-4 and 287-3 Wash: 210-4 and 287-5
3HAC9038-4	Control cable power 30 m	Foundry: 210-5 and 287-3 Wash: 210-5 and 287-5

ⁱ The option number depends on the protection type of the manipulator.

Power cables, IRB 1200, 1510, 1520

Art. no.	Description	Option no.
3HAC040503-007	Control cable power 3 m	210-1 (only for IRB 1200)
3HAC040503-001	Control cable power 7 m	210-2
3HAC040503-002	Control cable power 15 m	210-3
3HAC040503-003	Control cable power 22 m	210-4 (only for IRB 1200)
3HAC040503-004	Control cable power 30 m	210-5 (only for IRB 1200)

Power cables, IRB 120

Cable	Art. no.	Option no.
3HAC032694-001	Robot cable power 3 m	210-1
3HAC032695-001	Robot cable power 7 m	210-2
3HAC032696-001	Robot cable power 15 m	210-3

Power cables, IRB 260, 1600 (type B)²

Art. no.	Description	Option no. ⁱ
3HAC9038-1	Control cable power 7 m	Foundry: 210-2 and 287-3 Wash: 210-5 and 287-5
3HAC9038-2	Control cable power 15 m	Foundry: 210-3 and 287-3 Wash: 210-5 and 287-5
3HAC9038-3	Control cable power 22 m	Foundry: 210-4 and 287-3 Wash: 210-5 and 287-5

¹ IRB 1600/1660ID in standard protection, is available in type A and type B. For details about the robot types, see product manual for the robot.

² IRB 1600/1660ID in standard protection, is available in type A and type B. For details about the robot types, see product manual for the robot.

Continues on next page

7 Spare parts

7.3.1 Manipulator cables

Continued

Art. no.	Description	Option no. ⁱ
3HAC9038-4	Control cable power 30 m	Foundry: 210-5 and 287-3 Wash: 210-5 and 287-5

ⁱ The option number depends on the protection type of the manipulator.

Power cables, IRB 360

Art. no.	Description	Option no.
3HAC029903-001	Control cable, power and signal 3 m	(435-80 or 435-81 or 435-82)
3HAC029903-002	Control cable, power and signal 7 m	(435-80 or 435-81 or 435-82)
3HAC029903-003	Control cable, power and signal 15 m	(435-80 or 435-81 or 435-82)
3HAC029903-004	Control cable, power and signal 22 m	(435-80 or 435-81 or 435-82)
3HAC029903-005	Control cable, power and signal 30 m	(435-80 or 435-81 or 435-82)
3HAC029903-007	Control cable, power and signal 50 m	(435-80 or 435-81 or 435-82)
3HAC038411-001	Control cable, power and signal, stainless contact screws, 3 m	(435-80 or 435-81 or 435-82)
3HAC038411-002	Control cable, power and signal, stainless contact screws, 7 m	(435-80 or 435-81 or 435-82)
3HAC038411-003	Control cable, power and signal, stainless contact screws, 15 m	(435-80 or 435-81 or 435-82)
3HAC038411-004	Control cable, power and signal, stainless contact screws, 22 m	(435-80 or 435-81 or 435-82)
3HAC038411-005	Control cable, power and signal, stainless contact screws, 30 m	(435-80 or 435-81 or 435-82)
3HAC038411-006	Control cable, power and signal, stainless contact screws, 50 m	(435-80 or 435-81 or 435-82)

Power cables, IRB 390

Art. no.	Description	Option no.
3HAC040503-007	Control cable power 3 m	
3HAC040503-001	Control cable power 7 m	
3HAC040503-002	Control cable power 15 m	
3HAC040503-003	Control cable power 22 m	
3HAC040503-004	Control cable power 30 m	

Power cable, IRB 2400



Note

Depending on whether the manipulator is built before or after 2018-05, the connection interface differs and, the choice of manipulator cable must be made accordingly. Check the interface and select cable according to the following tables.

Continues on next page

Before May 2018

Art. no.	Description	Option no. ⁱ
3HAC2492-1	Control cable power 7 m	Standard: 210-2 and 287-4
3HAC2529-1	Control cable power 15 m	Standard: 210-3 and 287-4
3HAC2839-1	Control cable power 22 m	Standard: 210-4 and 287-4
3HAC2564-1	Control cable power 30 m	Standard: 210-5 and 287-4
3HAC9038-1	Control cable power 7 m	Foundry: 210-2 and 287-3 Wash: 210-5 and 287-5
3HAC9038-2	Control cable power 15 m	Foundry: 210-3 and 287-3 Wash: 210-5 and 287-5
3HAC9038-3	Control cable power 22 m	Foundry: 210-4 and 287-3 Wash: 210-5 and 287-5
3HAC9038-4	Control cable power 30 m	Foundry: 210-5 and 287-3 Wash: 210-5 and 287-5

ⁱ The option number depends on the protection type of the manipulator.

From May 2018

Art. no.	Description	Option no. ⁱ
3HAC9038-1	Control cable power 7 m	Standard: 210-2 and 287-4 Foundry: 210-2 and 287-3 Wash: 210-5 and 287-5
3HAC9038-2	Control cable power 15 m	Standard: 210-3 and 287-4 Foundry: 210-3 and 287-3 Wash: 210-5 and 287-5
3HAC9038-3	Control cable power 22 m	Standard: 210-4 and 287-4 Foundry: 210-4 and 287-3 Wash: 210-5 and 287-5
3HAC9038-4	Control cable power 30 m	Standard: 210-5 and 287-4 Foundry: 210-5 and 287-3 Wash: 210-5 and 287-5

ⁱ The option number depends on the protection type of the manipulator.

Power cables, IRB 4400

Art. no.	Description	Option no. ⁱ
3HAC2512-1	Control cable power 7 m	Standard: 210-2 and 287-4 Clean room: 210-2 and 287-1
3HAC2535-1	Control cable power 15 m	Standard: 210-3 and 287-4 Clean room: 210-3 and 287-1
3HAC2560-1	Control cable power 22 m	Standard: 210-4 and 287-4 Clean room: 210-4 and 287-1
3HAC2572-1	Control cable power 30 m	Standard: 210-5 and 287-4 Clean room: 210-5 and 287-1
3HAC8182-1	Control cable power 7 m	Foundry: 210-2 and 287-3 Wash: 210-2 and 287-5

Continues on next page

7 Spare parts

7.3.1 Manipulator cables

Continued

Art. no.	Description	Option no. ⁱ
3HAC8182-2	Control cable power 15 m	Foundry: 210-3 and 287-3 Wash: 210-3 and 287-5
3HAC8182-3	Control cable power 22 m	Foundry: 210-4 and 287-3 Wash: 210-4 and 287-5
3HAC8182-4	Control cable power 30 m	Foundry: 210-5 and 287-3 Wash: 210-5 and 287-5

ⁱ The option number depends on the protection type of the manipulator.

Power cable, IRB 460, 660, 760, 2600, 4600, 6620, 6640, 6650S, 6660, 6700, 7600, 8700

Art. no.	Description	Option no.
3HAC026787-001	Control cable power 7 m	(435-6 or 435-18 or 435-24 or 435-36) and 210-2
3HAC026787-002	Control cable power 15 m	(435-6 or 435-18 or 435-24 or 435-36) and 210-3
3HAC026787-003	Control cable power 22 m	(435-6 or 435-18 or 435-24 or 435-36) and 210-4
3HAC026787-004	Control cable power 30 m	(435-6 or 435-18 or 435-24 or 435-36) and 210-5



Note

IRB 8700 requires two power cables.

Power cables, IRB 6790

Cable	Art. no.	Option no.
3HAC063487-001	Robot cable power 7 m	210-2
3HAC063488-001	Robot cable power 15 m	210-3
3HAC063489-001	Robot cable power 22 m	210-4

7.3.2 Fan cables

Large manipulators

Art. no.	Description	Note
3HAC022723-001	Harness - Axis 1&2 cooling	(87-1 or 88-1 or 89-1) and 210-2
3HAC022723-004	Harness - Axis 1&2 cooling	(87-1 or 88-1 or 89-1) and 210-3
3HAC022723-005	Harness - Axis 1&2 cooling	(87-1 or 88-1 or 89-1) and 210-4
3HAC022723-006	Harness - Axis 1&2 cooling	(87-1 or 88-1 or 89-1) and 210-5
3HAC023599-001	Harness - Axis 1 cooling	IRB 6700

7 Spare parts

7.3.3 CP/CS Harness

7.3.3 CP/CS Harness

CP/CS for IRB 2600, 460, 4600, 660, 6620, 6640, 6650S, 6700, 760, 7600, 8700

Art. no.	Description	Option no.
3HAC022957-001	Harness CP/CS L=7m	94-1
3HAC022957-002	Harness CP/CS L=15m	94-2
3HAC022957-006	Harness CP/CS L=22m	94-3
3HAC022957-003	Harness CP/CS L=30m	94-4

CP/CS/Profibus for IRB 2600, 460, 4600, 660, 6620, 6640, 6650S, 6700, 760, 7600, 8700

Art. no.	Description	Option no.
3HAC022988-001	Harness CP/CS, PROFIB L=7m	92-2
3HAC022988-002	Harness CP/CS, PROFIB L=15m	92-3
3HAC022988-006	Harness CP/CS, PROFIB L=22m	92-4
3HAC022988-003	Harness CP/CS, PROFIB L=30m	92-5

CP/CS DeviceNet for IRB 2600, 460, 4600, 660, 6620, 6640, 6650S, 6700, 760, 7600, 8700

Art. no.	Description	Option no.
3HAC022978-001	Harness CP/CS, DeviceNet L=7m	90-2
3HAC022978-002	Harness CP/CS, DeviceNet L=15m	90-3
3HAC022978-006	Harness CP/CS, DeviceNet L=22m	90-4
3HAC022978-003	Harness CP/CS, DeviceNet L=30m	90-5

Ethernet/PROFINET cable for IRB 2600, 460, 4600, 660, 6620, 6640, 6650S, 6700, 760, 7600, 8700

Art. no.	Description	Option no.
3HAC031924-001	Connection of Ethernet, L=7m	859-1
3HAC031924-002	Connection of Ethernet, L=15m	859-2
3HAC031924-003	Connection of Ethernet, L=22m	859-3
3HAC031924-004	Connection of Ethernet, L=30m	859-4

Ethernet/PROFINET cable for IRB 1200

Art. no.	Description	Option no.
3HAC055518-001	Connection of Ethernet, L=3m	859-9
3HAC055518-002	Connection of Ethernet, L=7m	859-1
3HAC055518-003	Connection of Ethernet, L=15m	859-2
3HAC055518-004	Connection of Ethernet, L=22m	859-3
3HAC055518-005	Connection of Ethernet, L=30m	859-4

7.3.4 Cables customer power/customer signal

IRB 120, 1200

Art. no.	Description	Option no.
3HAC049089-001	Cable CP/CS 3 m	16-1 and 94-6
3HAC049089-004	Cable CP/CS 7 m	16-1 and 94-1
3HAC049089-005	Cable CP/CS 15 m	16-1 and 94-2
3HAC049089-006	Cable CP/CS 22 m	16-1 and 94-3
3HAC049089-007	Cable CP/CS 30 m	16-1 and 94-4

IRB 1400

Art. no.	Description	Option no.
3HAC3346-1	Cable CP/CS 7 m	16-1 and 17-5 and 94-1
3HAC3347-1	Cable CP/CS 15 m	16-1 and 17-5 and 94-2
3HAC3348-1	Cable CP/CS 22 m	16-1 and 17-5 and 94-3
3HAC3349-1	Cable CP/CS 30 m	16-1 and 17-5 and 94-4

IRB 2400

**Note**

Depending on whether the manipulator is built before or after 2018-05, the connection interface differs and, the choice of manipulator cable must be made accordingly. Check the interface and select cable according to the following tables.

Before May 2018

Art. no.	Description	Option no. ⁱ
3HAC3353-1	Cable CP/CS 7 m	Standard: 94-1, 16-1 and 287-4
3HAC3354-1	Cable CP/CS 15 m	Standard: 94-2, 16-1 and 287-4
3HAC3355-1	Cable CP/CS 22 m	Standard: 94-3, 16-1 and 287-4
3HAC3356-1	Cable CP/CS 30 m	Standard: 94-1, 16-1 and 287-4
3HAC8183-1	Cable CP/CS 7 m	Foundry: 94-1, 16-1 and 287-3 Wash: 94-1, 16-1 and 287-5
3HAC8183-2	Cable CP/CS 15 m	Foundry: 94-2, 16-1 and 287-3 Wash: 94-2, 16-1 and 287-5
3HAC8183-3	Cable CP/CS 22 m	Foundry: 94-3, 16-1 and 287-3 Wash: 94-3, 16-1 and 287-5
3HAC8183-4	Cable CP/CS 30 m	Foundry: 94-4, 16-1 and 287-3 Wash: 94-4, 16-1 and 287-5

ⁱ The option number depends on the protection type of the manipulator.

Continues on next page

7 Spare parts

7.3.4 Cables customer power/customer signal

Continued

From May 2018

Art. no.	Description	Option no. ⁱ
3HAC8183-1	Cable CP/CS 7 m	Standard: 94-1, 16-1 and 287-4 Foundry: 94-1, 16-1 and 287-3 Wash: 94-1, 16-1 and 287-5
3HAC8183-2	Cable CP/CS 15 m	Standard: 94-2, 16-1 and 287-4 Foundry: 94-2, 16-1 and 287-3 Wash: 94-2, 16-1 and 287-5
3HAC8183-3	Cable CP/CS 22 m	Standard: 94-3, 16-1 and 287-4 Foundry: 94-3, 16-1 and 287-3 Wash: 94-3, 16-1 and 287-5
3HAC8183-4	Cable CP/CS 30 m	Standard: 94-4, 16-1 and 287-4 Foundry: 94-4, 16-1 and 287-3 Wash: 94-4, 16-1 and 287-5

ⁱ The option number depends on the protection type of the manipulator.

IRB 4400

Art. no.	Description	Option no. ⁱ
3HAC3353-1	Cable CP/CS 7 m	Standard: 94-1, 16-1 and 287-4 Clean: 94-1, 16-1 and 287-1
3HAC3354-1	Cable CP/CS 15 m	Standard: 94-2, 16-1 and 287-4 Clean: 94-2, 16-1 and 287-1
3HAC3355-1	Cable CP/CS 22 m	Standard: 94-3, 16-1 and 287-4 Clean: 94-3, 16-1 and 287-1
3HAC3356-1	Cable CP/CS 30 m	Standard: 94-4, 16-1 and 287-4 Clean: 94-4, 16-1 and 287-1
3HAC8183-1	Cable CP/CS 7 m	Foundry: 94-1, 16-1 and 287-3 Wash: 94-1, 16-1 and 287-5 Foundry Prime: 94-1, 16-1 and 287-6
3HAC8183-2	Cable CP/CS 15 m	Foundry: 94-2, 16-1 and 287-3 Wash: 94-2, 16-1 and 287-5 Foundry Prime: 94-2, 16-1 and 287-6
3HAC8183-3	Cable CP/CS 22 m	Foundry: 94-3, 16-1 and 287-3 Wash: 94-3, 16-1 and 287-5 Foundry Prime: 94-3, 16-1 and 287-6
3HAC8183-4	Cable CP/CS 30 m	Foundry: 94-4, 16-1 and 287-3 Wash: 94-4, 16-1 and 287-5 Foundry Prime: 94-4, 16-1 and 287-6

ⁱ The option number depends on the protection type of the manipulator.

IRB 1600

Art. no.	Description	Option no.
3HAC8183-1	Cable CP/CS 7 m	94-1, 16-1 and 17-5
3HAC8183-2	Cable CP/CS 15 m	94-2, 16-1 and 17-5

Continues on next page

Art. no.	Description	Option no.
3HAC8183-3	Cable CP/CS 22 m	94-3, 16-1 and 17-5
3HAC8183-4	Cable CP/CS 30 m	94-4, 16-1 and 17-5

IRB 260

Art. no.	Description	Option no.
3HAC8183-1	Cable CP/CS 7 m	94-1 and 16-1
3HAC8183-2	Cable CP/CS 15 m	94-2 and 16-1
3HAC8183-3	Cable CP/CS 22 m	94-3 and 16-1
3HAC8183-4	Cable CP/CS 30 m	94-4 and 16-1

IRB 360, 390

Art. no.	Description	Option no. ⁱ
3HAC14860-1	Cable CP/CS 7 m	218-9 and 94-1
3HAC14860-2	Cable CP/CS 15 m	218-9 and 94-2
3HAC14860-3	Cable CP/CS 22 m	218-9 and 94-3
3HAC14860-4	Cable CP/CS 30 m	218-9 and 94-4

ⁱ The option number depends on the protection type of the manipulator.

7 Spare parts

7.3.5 Other customer cables

7.3.5 Other customer cables

IRB 360

Art. no.	Description	Option no. ⁱ
3HAC030198-001	Internal Customer cable 3 m	218-5 and 94-6
3HAC030198-002	Internal Customer cable 7 m	218-5 and 94-1
3HAC030198-003	Internal Customer cable 15 m	218-5 and 94-2
3HAC030198-004	Internal Customer cable 22 m	218-5 and 94-3
3HAC030198-005	Internal Customer cable 30 m	218-5 and 94-4

ⁱ The option number depends on the protection type of the manipulator.

Euromap cables

Art. no.	Description	Option no.
3HAC024328-001	Cable EMP67 10 m	671-2 and 673-1
3HAC024328-005	Cable EMP67 15 m	671-2 and 673-2
3HAC024330-001	Cable EMP12 10 m	671-1 and 673-1
3HAC024330-004	Cable EMP12 15 m	671-1 and 673-2

7.3.6 Additional cables**Drive module cables**

Cable	Art. no.	Option no.
3HAC025600-001	Cable between control module and drive module: L=1.7 m	
3HAC025600-005	Cable between control module and drive module: L=4 m	761-1
3HAC025600-006	Cable between control module and drive module: L=30 m	761-3

This page is intentionally left blank

8 Circuit diagrams

8.1 Circuit diagrams

Overview

The circuit diagrams are not included in this manual, but are available for registered users via ABB Robotics One, <https://one.robotics.abb.com/en/knowledge-hub>.

See the article numbers in the tables below.

Controllers

Product	Article numbers for circuit diagrams
<i>Circuit diagram - IRC5</i>	<i>3HAC024480-011</i>

Manipulators

Product	Article numbers for circuit diagrams
<i>Circuit diagram - IRB 120</i>	<i>3HAC031408-003</i>
<i>Circuit diagram - IRB 140 type C</i>	<i>3HAC6816-3</i>
<i>Circuit diagram - IRB 260</i>	<i>3HAC025611-001</i>
<i>Circuit diagram - IRB 360</i>	<i>3HAC028647-009</i>
<i>Circuit diagram - IRB 390</i>	<i>3HAC060545-009</i>
<i>Circuit diagram - IRB 460</i>	<i>3HAC036446-005</i>
<i>Circuit diagram - IRB 660</i>	<i>3HAC025691-001</i>
<i>Circuit diagram - IRB 760</i>	<i>3HAC025691-001</i>
<i>Circuit diagram - IRB 1200</i>	<i>3HAC046307-003</i>
<i>Circuit diagram - IRB 1410</i>	<i>3HAC2800-3</i>
<i>Circuit diagram - IRB 1600/1660</i>	<i>3HAC021351-003</i>
<i>Circuit diagram - IRB 1510</i>	<i>3HAC087368-003</i>
<i>Circuit diagram - IRB 1520</i>	<i>3HAC039498-007</i>
<i>Circuit diagram - IRB 2400</i>	<i>3HAC6670-3</i>
<i>Circuit diagram - IRB 2600</i>	<i>3HAC029570-007</i>
<i>Circuit diagram - IRB 4400/4450S</i>	<i>3HAC9821-1</i>
<i>Circuit diagram - IRB 4600</i>	<i>3HAC029038-003</i>
<i>Circuit diagram - IRB 6620</i>	<i>3HAC025090-001</i>
<i>Circuit diagram - IRB 6620 / IRB 6620LX</i>	<i>3HAC025090-001</i>
<i>Circuit diagram - IRB 6640</i>	<i>3HAC025744-001</i>
<i>Circuit diagram - IRB 6650S</i>	<i>3HAC13347-1</i> <i>3HAC025744-001</i>
<i>Circuit diagram - IRB 6660</i>	<i>3HAC025744-001</i> <i>3HAC029940-001</i>
<i>Circuit diagram - IRB 6700 / IRB 6790</i>	<i>3HAC043446-005</i>

Continues on next page

8 Circuit diagrams

8.1 Circuit diagrams

Continued

Product	Article numbers for circuit diagrams
<i>Circuit diagram - IRB 7600</i>	<i>3HAC13347-1 3HAC025744-001</i>
<i>Circuit diagram - IRB 14000</i>	<i>3HAC050778-003</i>
<i>Circuit diagram - IRB 910SC</i>	<i>3HAC056159-002</i>

Index

3

3rd party software, 325

A

additional drive module, 187
 additional drive unit, 118
 allergenic material, 36
 aluminum
 disposal, 314
 ARU bleeder, 296
 assessment of hazards and risks, 36
 automatic fuse, 223
 automatic mode, 35
 automatic stop
 function test, 219
 auto stop jumper, 82

B

backup energy bank, repair, 234

Base

 Scalable, 127

batteries

 disposal, 314

bleeder, 294

bolt pattern, 51

brake contactor, 218

brake resistor bleeder, 294

brominated flame retardants

 disposal, 314

C

cabinet lock, 37

cables, 78

carbon dioxide extinguisher, 37

category 0 stop, 29

category 1 stop, 29

category 3, 20

CCF, 20

cleaning of the controller, 208

cleaning the FlexPendant, 211

climbing on robot, 40

Common Cause Failures, 20

Configuration of the drive system, 118

connecting a USB memory, 122

connection

 FlexPendant, 91

 manipulator cables, 78

contactor auxiliary blocks, 90

contactor interface board, repair, 281

controller

 symbols, 26

copper

 disposal, 314

D

DC, 20

Diagnostic Coverage, 20

disposal of storage media, 313

Drive functions, 117

drive modules, 106

drive system, 118

drive system fan, repair, 284

drive system fan sensor, 191, 287

drive unit, 118, 262

DSQC1015, 168, 275

E

earth fault breaker, 213

Electronic Position Switches, 154, 267

emergency stop, 29, 214

emergency stops, 31

enabling device, 32, 137

 function test, 216

EN ISO 13849-1, 20, 22

environmental information, 314

EPS board, 154, 267

ESD

 damage elimination, 49

 sensitive equipment, 49

esd elimination, 44, 49

EtherNet/IP, 127

expansion board, replace, 248

external enabling device, 137

external operator's panel, 133

external safety relay, 81

F

fan sensor, 191, 287

fieldbus adapter, replace, 251

fire extinguishing, 37

FlexPendant

 connecting, 91

 connecting in operation, 94

 disconnecting, 94

 hot plug, 94

 jumper plug, 94

FlexPendant holder, 53

full load current, 73

function tests, 213

G

general stop, 220

H

hanging

 installed hanging, 36

hazard levels, 24

hazardous material, 314

Heat exchange unit and fan, repair, 236

height

 installed at a height, 36

hold-to-run, 32

hot plug, 94

hot surfaces, 40

HRA, 36

I

I/O device, 127

I/O signals, 80

I/O units and gateways, repair, 232

Inspection of controller, 203

installation activities, 45

Installation of I/O, Gateways and encoder units, 142

installation space, 50

integrator responsibility, 36

IP class, 48

ISO 13849-1, 20

J

jumper plug, 94

K

key of the mode switch, 39

L

labels

controller, 26

lead

disposal, 314

licenses, 325

lifting device, 46

limitation of liability, 19

limiting robot motion, 36

limit switch, 222

Lithium

disposal, 314

lock and tag, 37

M

main drive unit, 118

Main Drive Unit, 262

maintenance schedule, 201

manipulator cables, 78

manual full speed mode, 33

manual high speed mode, 33

manual mode, 33

manual reduced speed, 33

MDU bleeder, 296

mechanical limiting, 36

memory, 259

memory functions, 121

mode switch, 215

mode switch key, 39

motor contactors, 217

MOTORS ON/MOTORS OFF, 89

MOTORS ON/MOTORS OFF circuit, 83

MTTF_D, 20–21

MultiMove, 187

N

national regulations, 36

network security, 17

O

open source software, OSS, 325

operating conditions, 47

operating mode

automatic mode, 35

manual full speed mode, 33

manual mode, 33

manual reduced speed, 33

operator's panel, 133

options

hot plug button, 94

original spare parts, 19

P

panel board, repair, 226

PClexpress boards, replace, 244

pedestal

installed on pedestal, 36

performance level, PL, 20

personnel

requirements, 23

PFH_D, 22

PL, performance level, 20

plastic

disposal, 314

Plug & Produce, 127

Power supply

Connecting power supply to the controller, 72

PPE, 23

product standards, 318

protection class, 48

protective equipment, 23

protective stop

definition, 29

protective wear, 23

R

rated voltage, 73

recovering from emergency stops, 31

rectifiers, 118

recycling, 314

reduced speed control

function test, 224

regional regulations, 36

replacements, report, 225

replacing

contactor interface board, 281

expansion board, 248

fieldbus adapter, 251

PClexpress boards, 244

SD-card memory, 259

report replacements, 225

required performance level, PLr, 20

responsibility and validity, 19

risk of burns, 40

rubber

disposal, 314

S

safeguarding, 29

safeguard mechanisms

automatic mode, 35

manual mode, 33

SafeMove, 168, 244, 275

safety

ESD, 49

fire extinguishing, 37

signals, 24

signals in manual, 24

stop functions, 29

symbols, 24

symbols on controller, 26

safety controller, 154, 267

safety devices, 37

safety module, 168, 244

Safety module, 275

safety signals, 79

in manual, 24

safety standards, 318

Scalable

Base, 127

Scalable I/O, 127

SCCR, 72

SD-card memory, replace, 259

sensitive protective equipment, SPE, 37

sensor, drive system fan, 191, 287

separation distance, 36

servo disconnect, 112

shielded cables, 80

shipping, 313

short circuit current rating, 72

signal cables, 80

- signals
 - safety, 24
- software based limiting, 36
- software licenses, 325
- standards, 318
 - ANSI, 318
 - CAN, 318
 - EN IEC, 318
 - EN ISO, 318
- steel
 - disposal, 314
- stop category 0, 29
- stop category 1, 29
- stops
 - overview, 29
- storage conditions, 47
- superior stop, 221
- symbols
 - safety, 24
- system integrator requirements, 36

- T**
 - temperature, 47
 - temp sensor, drive system fan, 191, 287
 - three-position enabling device, 32
 - function test, 216
 - tightening torque, 321
 - transformer, 73
 - transportation, 313
 - troubleshooting
 - safety, 41

- U**
 - upcycling, 314
 - USB ports, 122
 - users
 - requirements, 23

- V**
 - validity and responsibility, 19

- W**
 - weight, 48
 - wrist strap, 44, 49



ABB Robotics Sweden AB
S-721 71 VÄSTERÅS, Sweden
Telephone +46 10-732 50 00

ABB Robotics Norway AS
Nordlysvegen 7, N-4340 BRYNE, Norway
Box 265, N-4349 BRYNE, Norway
Telephone: +47 22 87 2000

ABB Robotics (Shanghai) Limited
No. 39, 99 Miaoqiao Road,
Pudong New Area,
Shanghai, China
Telephone: +86 21 6105 6666

ABB Inc.
Robotics & Discrete Automation
1250 Brown Road
Auburn Hills, MI 48326
USA
Telephone: +1 248 391 9000

abb.com/robotics